

P. R. 685

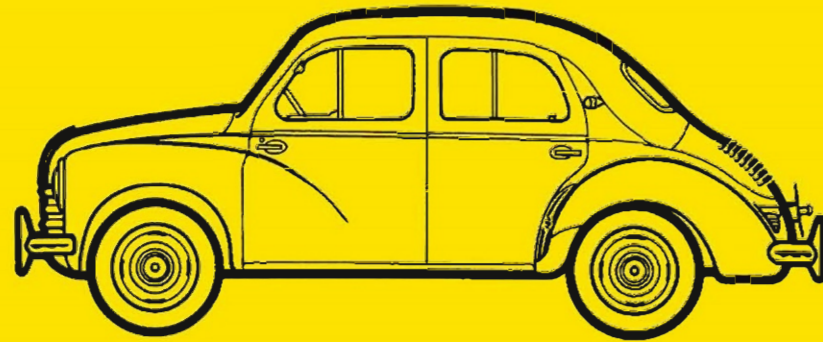

**CATALOGUE
DE PIÈCES
DE RECHANGE**

4CV

RENAULT

(750 CC)

**R. 1060 - R. 1062
R. 2070 - R. 2071**



P. R. 685 "1961" :
Annule et remplace P. R. 597

F. — Les pages vertes et les pages roses de ce catalogue donnent toutes indications relatives à son utilisation.

P. R. 685 "1961" :
Cancels and replaces P. R. 597

E. A. — The green and pink sheets of this catalogue give all information concerning its use.

P. R. 685 "1961" :
Anula y sustituye a P. R. 597

E. E. — Las páginas verdes y rosas de este catálogo contienen todas las indicaciones referentes a su empleo.

P. R. 685 "1961" :
Cancels and replaces P. R. 597

E. A. (US). — The green and pink sheets of this catalogue give full information concerning its use.

P. R. 685 "1961" :
Anulla e rimpiazza P. R. 597

E. It. — Le pagine verdi e le pagine rosa di questo catalogo vi danno tutte le indicazioni relative alla sua utilizzazione.

P. R. 685 "1961" :
Annulliert und ersetzt P. R. 597

E. D. — Die grünen und rosa Seiten dieses Katalogs enthalten sämtliche Hinweise bezüglich seiner Benutzung.

P. R. 685 "1961" :
Vernietigen en vervangen P. R. 597

E. NL. — Voor gebruiksaanwijzing, zie groene en rose paginas.

P. R. 685 "1961" :
Ophæver og erstatter P. R. 597

E. Dk. — Brugsanvisningen angives på de grønne og lyserode sider i kataloget.

P. R. 685 "1961" :
Upphålfvar och ersätter P. R. 597

E. S. — All nödvändig information om denna katalogs användning återfinnes på de skära och gröna sidorna.

01.00

A (F.) P.R. 685

01.00

A (F.) P.R. 685

P. R. 685
Catalogue
de pièces de rechange pour

4 CV RENAULT (750 cc)

R. 1060 - R. 1062

R. 2070 - R. 2071



PIECES D'ORIGINE

Régie Nationale des Usines Renault
Billancourt - France

R. C. Seine N° 55-B-8 620 - N° d'entrep. : 261 75012 9001

Téléphone : MOLitor 52-00 - MOLitor 26-00

Adresse télégraphique : RENO FER - PARIS

Telex - PARIS : 20 094

pages
vertes

Avant-
propos

pages
roses

Répertoire
des planches

pages
blanches

Planches

pages
bleues

Répertoire
numérique

Numéro des pièces	Numéro des planches	Quantité par véhicule
colonne 1	colonne 2	colonne 3

02.00

A (F.) P.R. 685

Emplacement des numéros de véhicule et d'organes

02.00

A (F.) P.R. 685

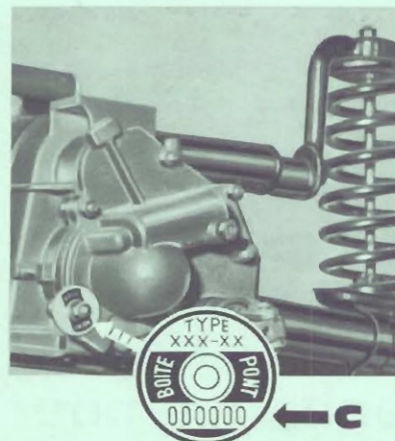
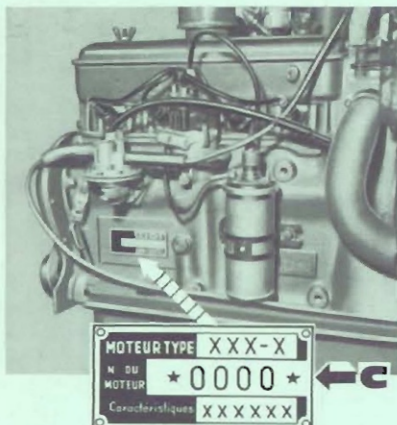
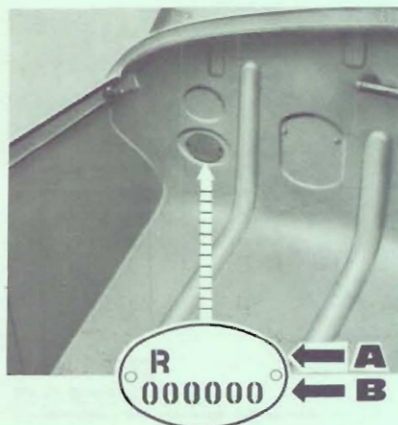

Indications essentielles

Pour obtenir une fourniture correcte de pièces de rechange

sur le véhicule

- A** Le type du véhicule
- B** Le numéro de fabrication du véhicule
- C** Le numéro de fabrication de l'organe dont fait partie la pièce commandée

dans le catalogue

Le numéro de la pièce

Ce numéro peut comporter 7, 9 ou 10 chiffres; il est indispensable qu'il figure au complet dans vos commandes.

Exemple : 9906574 16

La quantité désirée



PIECES D'ORIGINE

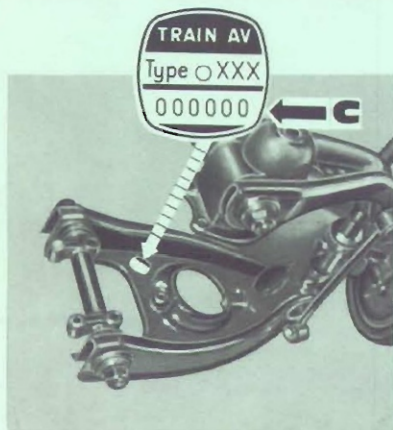

NOTA

- 1^{er} Pour simplifier les vérifications, il serait souhaitable d'indiquer également dans les commandes
 - le numéro du catalogue,
 - le numéro de la planche illustrée.



- 2^e Si les numéros d'organes, ou de véhicule, sont détruits, indiquer le numéro de la plaque constructeurs rappelé sur la carte de garantie.

INTRODUCTION

Le présent document contient tous les ensembles et pièces détachées montés d'origine reconnaissables à la marque et vendables en rechange ; il permet de déterminer avec précision leurs numéros et de les identifier facilement par les illustrations.



Ces ensembles et ces pièces sont répartis par **planche** suivant l'organe ou l'élément d'organe auquel ils se rattachent.

Chaque **planche** est identifiée par un numéro à 4 chiffres dont les deux premiers correspondent à un code organe déterminé ; elle peut être caractérisée par une variante ou un point de départ

dans le cas où elle s'identifie avec une planche similaire.

Une planche se compose :

— de l'illustration des pièces et ensembles contenus dans la planche et qui diffèrent de forme ; à chaque pièce illustrée correspond un ou plusieurs numéros de pièces caractérisés entre eux par une variante ou un signe codifié.

— et, éventuellement, de **tableaux** comportant des renseignements complémentaires tels que points de départ et consignes. Ces tableaux figurent soit en bas de l'illustration, soit sur une page annexe à l'illustration.

Remarque : la signification des signes et expressions codifiés utilisés dans

chaque planche, est indiquée dans la planche n° 05.00.

Un répertoire des planches, en tête de celles-ci, donne la correspondance entre leurs numéros et leurs **désignations technologiques**.

Un répertoire numérique en fin de catalogue donne la correspondance entre les numéros de pièces et les numéros de planches ainsi que les quantités de pièces par véhicule dans la planche considérée, sauf pour les numéros de boulonnerie normalisée. Le document « DC 521 » donne la signification des numéros codifiés de la boulonnerie normalisée.

UTILISATION

Détermination du numéro d'une pièce connaissant la nature de celle-ci :

1. Rechercher dans le **répertoire des planches** la planche correspondant à l'organe ou l'élément d'organe auquel cette pièce peut se rattacher.
2. Compulser le catalogue pour y retrouver cette planche en tenant compte éventuellement, du point de départ ou de la variante caractérisant la planche.
3. La planche étant déterminée, rechercher l'illustration de la pièce désirée.

A cette illustration correspond un ou plusieurs numéros. Choisir celui qui convient, compte tenu des signes ou expressions codifiés les caractérisant.

Les renvois numériques ou alphabétiques affectés aux numéros de pièces, assurent la liaison entre ces numéros et les renseignements complémentaires s'y rapportant, contenus dans les tableaux situés soit en bas de l'illustration soit en page annexe.

Vérification d'un bon de commande rédigé suivant les indications formulées ci-contre et par une personne ayant utilisé un bulletin périodique, ou un lot de pièces ou même un catalogue.

1. Rechercher dans le **répertoire numérique**, au numéro de pièce donné par le bon de commande, les numéros de planches correspondantes.

2. Consulter ces planches pour vérifier si le numéro de pièce est bien celui qui convient compte tenu des points de départ affectés à ce numéro et du numéro de véhicule ou d'organe pour lequel la pièce est commandée.

Identification par l'illustration d'une pièce dont on connaît le numéro.

1. Rechercher dans le **répertoire numérique**, au numéro de pièce donné, le numéro des planches correspondantes.
2. Consulter ces planches.

Pièces d'origine Renault

Nous tenons à avertir notre clientèle que l'on vend des imitations de nos pièces de rechange.

Ces pièces sont souvent exécutées avec des matières premières défectueuses ou ayant subi un mauvais traitement; de plus, elles laissent à désirer comme usinage et interchangeabilité.

Afin de mettre en garde notre clientèle contre des contrefaçons, nous poinçonnons de notre nom ou de notre marque :

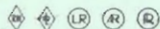

la plupart de nos pièces détachées, les autres portent une bande ou plomb de garantie de notre marque.

Nous prions donc nos clients d'exiger notre marque de fabrique sur les pièces qui leur seraient délivrées par des intermédiaires.

Nous attirons également l'attention de notre clientèle sur le fait que le montage sur nos véhicules de pièces de qualité inférieure peut, en plus des ruptures et déformations qu'elles peuvent subir, entraîner la détérioration d'autres pièces montées d'origine.

La garantie dont nous couvrons nos véhicules pendant six mois sera retirée à tout véhicule sur lequel des pièces montées par nous auront été remplacées par des pièces d'une autre origine.

Tous nos Agents ont pris par contrat, l'engagement de ne vendre que des pièces d'origine et de porter sur les factures la mention : « Pièces de rechange garanties d'origine ». Dans votre intérêt et pour votre sécurité, exigez cette indication sur les factures de pièces de rechange que vous achetez.

Commande de pièces de rechange**a) Règles générales.**

Pour toute commande de pièces de rechange, notre clientèle doit s'adresser exclusivement :

soit aux Succursales,
soit aux Concessionnaires,
soit aux Agents

habilités à la vente des véhicules de notre marque.

b) Commande de dépannage.

Les commandes urgentes de dépannage adressées à nos distributeurs doivent toujours indiquer les renseignements formulés sur la planche 02.00 :

1. le type du véhicule R...
2. le numéro de fabrication du véhicule
3. le numéro de fabrication de l'organe intéressé (s'il y a lieu)
4. le numéro de pièce
5. la quantité de pièces désirée et éventuellement la désignation de celles-ci.

De plus, pour simplifier les vérifications du service de documentation, il est souhaitable d'indiquer :

6. le numéro du catalogue PR...
7. le numéro de la planche considérée.

c) Commande de stock.

Les commandes doivent être formulées en indiquant uniquement :

le numéro de pièce et la quantité désirée.

Tarif

Les prix que nous communiquons sont donnés à titre indicatif et sans engagement de notre part. Les prix facturés sont toujours ceux en vigueur au moment de la livraison.

Retour de pièces

Attention. Tout « retour de pièces », devra avoir fait l'objet d'une demande préalable « de retour » au magasin de pièces de rechange qui a facturé ces pièces.

Chaque pièce devra être obligatoirement accompagnée d'une étiquette mentionnant les renseignements ci-dessous :

1. Le motif du retour et l'accord donné à celui-ci.
2. Le nom et l'adresse de l'expéditeur.
3. Le numéro de la pièce (et éventuellement, sa désignation).
4. Le numéro de la commande pour les envois de pièces modèles.
5. Le numéro et la date de la facture afférente aux pièces retournées.

L'expédition de ces pièces devra être faite franco de port.

Nota. - Les pièces en retour devront être en parfait état.

Remarques générales

1. Certaines pièces de tôlerie ne sont livrées que tant que l'état de l'outillage en permet la fabrication.
2. Dans le cas de commande de tissus ou simili, joindre un échantillon. La longueur désirée doit être exprimée en décimètres. La fourniture conforme n'est assurée que selon les possibilités d'approvisionnement. Dans certains cas, les usines de montage à l'étranger réalisent elles-mêmes l'habillage des véhicules. Elles proposent alors un choix différent de garnitures.

Contestation

En cas de contestation, le Tribunal de la Seine sera seul compétent de convention expresse, même en cas de demande incidente ou en garantie. Nos dispositions, acceptations de règlement ou expéditions n'opèrent ni novation, ni dérogation à cette clause attributive de juridiction.

Pièces d'origine Renault

Par contrat vous vous êtes engagés à ne vendre à votre clientèle que des pièces de rechange d'origine **Renault**, nous vous rappelons que nous retirons notre garantie lorsque des pièces montées dans nos usines sont remplacées par des pièces d'une autre origine.

Cet engagement ne s'applique pas toutefois à certains accessoires pour lesquels nous avons accepté sur votre demande, une dérogation.

Afin d'éviter toute contrefaçon, nous poinçons la plupart de nos pièces de rechange comme suit :

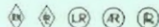

les autres pièces comportant une bande ou un plomb de garantie de notre marque.

Commande de pièces de rechange

a) Règles générales :

Afin d'éviter des erreurs à la livraison, observer les principes suivants :

Établir de préférence une commande importante, plutôt que plusieurs petites commandes.

Mentionner sur vos commandes :

1. Un numéro d'ordre pour faciliter les échanges de correspondance.
2. La marque spéciale à porter sur les caisses d'expédition.
3. En cas de nécessité d'un permis d'exportation : Rappeler la durée de celui-ci pour permettre d'effectuer l'expédition dans les délais impartis.
4. Le nom de votre transitaire si besoin est.

b) Commande de dépannage.

Indiquer toujours les renseignements formulés sur la planche 02.00:

1. le type du véhicule R...
2. le numéro de fabrication du véhicule.
3. le numéro de fabrication de l'organe intéressé (s'il y a lieu).
4. le numéro de pièce.
5. la quantité de pièces désirée et éventuellement la désignation de celles-ci.

De plus, pour simplifier les vérifications du service documentation, il est souhaitable d'indiquer :

6. le numéro de catalogue P.R.
7. le numéro de la planche considérée.

c) Commande de stock.

1. Pour une **constitution de stock**, en plus des numéros de pièces porter sur la commande la mention « Constitution de stock » et indiquer si possible le type et les numéros de fabrication des véhicules en circulation dans votre parc.

2. Pour un **renouvellement de stock**, en plus des numéros de pièces, indiquer sur vos commandes la mention « Renouvellement de stock ».

Tarifs et modes de paiement

Les prix vous sont communiqués à titre indicatif et sans engagement de notre part : la facturation est faite aux prix en vigueur au moment de la livraison.

Notre tarif s'entend départ usines : votre règlement devra donc comprendre, en plus du prix des pièces, les frais de transport, d'assurance, etc. si vous exigez l'expédition C.I.F.

Réclamations

Pour toute réclamation concernant un envoi de pièces de rechange, rappelez :

1. le motif du litige ;
2. le numéro et la date de la commande ;
3. le numéro et la date de la facture ;
4. le numéro du colis dans lequel était ou aurait dû se trouver la pièce ;
5. le numéro de la pièce relevé sur la facture ou le bon de livraison et, éventuellement, la désignation de celle-ci dans une langue courante.

Retour de pièces

Attention. Tout « retour de pièces », devra avoir fait l'objet d'une demande préalable « de retour » au magasin de pièces de rechange qui a facturé ces pièces.

Chaque pièce devra être obligatoirement accompagnée d'une étiquette mentionnant les renseignements ci-dessous :

1. Le motif du retour et l'accord donné à celui-ci.
2. Le nom et l'adresse de l'expéditeur.
3. Le numéro de la pièce (et éventuellement sa désignation).
4. Le numéro de la commande pour les envois de pièces modèles.
5. Le numéro et la date de la facture afférente aux pièces retournées.

L'expédition de ces pièces devra être faite franco de port.

Tout colis sera annoncé par lettre, indiquant :

1. le numéro du colis ;
2. le nom du transitaire et le mode d'expédition.

Lorsque vous effectuez un retour, par voie maritime ou ferrée, veuillez nous adresser le colis toujours sous régime de douane et en port payé à l'adresse suivante : RNUR - en gare des **Moulineaux-Billancourt (Seine), France.**

Il est indispensable de joindre le bon de livraison qui avait servi à notre expédition.

Nota. Les pièces en retour devront être en parfait état.

Remarques générales

1. Certaines pièces de tôlerie ne sont livrées que tant que l'état de l'outillage en permet la fabrication.
2. Dans le cas de commande de tissus ou simili, joindre un échantillon. La longueur désirée doit être exprimée en décimètres. La fourniture conforme n'est assurée que selon les possibilités d'approvisionnement. Dans certains cas, les usines de montage à l'étranger réalisent elles-mêmes l'habillage des véhicules. Elles proposent alors un choix différent de garnitures.

Contestation

En cas de contestation, le Tribunal de la Seine sera seul compétent de convention expresse, même en cas de demande incidente ou en garantie. Nos conditions, acceptations de règlement ou expédition n'opèrent ni novation, ni dérogation à cette clause attributive de juridiction.



Exportation

Filtrage compound
ou tropiques

à

Projecteur
faisceau symétriqueProjecteur
faisceau asymétrique

Hautes altitudes



A épuiser

Après épuisement
prévoirConsignes
d'interchangeabilitéNuméros de véhicules
ou d'organes

Direction à gauche

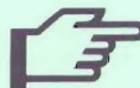

Direction à droite



Voir planche

Pièces à prévoir
en supplément

A = Ampère
AC = Avec chauffage
AH = Ampère heure
BP = Boîte-pont
C = Couleur
CF = Pays membre de la communauté française
DE = Diamètre extérieur
DI = Diamètre intérieur
DIR = Direction
E = Epaisseur
EQ = Equipement
ER = Echange réparation

F = Feutre
G = Poids en Grammes
H = Hauteur totale
LA = Largeur totale
LO = Longueur totale
M = Moquette
MEC = Mécanisme
MOT = Moteur
N = Nombre de dents
OC = Orifice calibré
P = Percalé

REF = Référence extérieure
S = Simili cuir
SC = Sans chauffage
T = Tissu
TAR = Train arrière
TAV = Train avant
V = Volts
VADM = Vente au décimètre
VAM = Vente au mètre
VEH = Véhicule
VENLO = Vente en longueur déterminée
W = Watt



- 1** Pièces réparation (pour moteur dont les chemises sont réalésables au diamètre de 55,8 mm. A livrer à prix forfaitaire par les centres « Échange réparation » contre remise des 4 chemises et des 4 pistons usagés).
Prévoir en outre : 9.808.473 - 1.
Pièces neuves (pour moteur dont les chemises ayant atteint la cote limite diam. : 55,8 mm, ne sont plus réalésables).
Prévoir en outre : 9.810.987 - 1.
- 7** Prévoir en outre : Sauf véhicule repris en clientèle portant un numéro de train avant antérieur : 6.035.487 - 1.
- 9** Prévoir la fourniture par paire.
- 11** Après épuisement des segments de freins avec garnitures tissées pour toute demande de segments (un ou plusieurs) pour un même véhicule, prévoir l'ensemble des segments garnis de matière moulée permettant d'équiper entièrement le véhicule.
Pour mémoire, cette fourniture comprendra :
- a) Pour freins à points fixes :
9.814.820 - 2.
9.814.821 - 2.
- b) Pour freins à segments flottants :
9.815.186 - 2.
9.815.185 - 2.
- 12** Opération à effectuer, après assemblage du tambour sur flasque et arbre de roue, reprendre au tour l'alésage du tambour pour mise à la cote définitive de 180, 25 H 9 afin d'obtenir une concentricité parfaite des pièces assemblées.
- 13** Opération à effectuer : Agrandir de 10,5 mm à 18,5 mm les encoches de centrage du plateau de frein sur tube fusée ;
Prévoir en outre : 8.231.123 - 1.
9.815.157 - 1.
6.037.600 - 1.
6.037.596 - 2.
6.031.266 - 1.
- 14** Après épuisement des ensembles comportant l'axe de coussinet de fixation d'amortisseur pourvu d'un trou de passage de goupille (destiné à recevoir un écrou crénelé).
Prévoir en outre : 8.524.860 - 1.
- 15** Après épuisement des axes pourvus d'un trou de passage de goupille.
Prévoir en outre : 8.524.860 - 1.
- 20** Sur remplacement d'un seul ressort, il est indispensable de vérifier la hauteur du nouveau ressort non remplacé et de toujours monter le ressort le plus haut du côté conducteur. (Suivant feuille d'instruction n° X-5.525.119).
- 21** Prévoir la fourniture par paire.
- 25** Après épuisement de 8.210.722, obturer le trou, diamètre : 58 mm, par collage d'un carton ou pose d'une plaquette rivée.
- 27** Opération à effectuer : Démontez la serrure à condamnation intérieure et la remplacer par l'ancienne serrure à condamnation extérieure en perçant un trou de 20 mm pour le passage du barillet suivant note RENAULT-SERVICE n° 1019.
- 30** Sur demande d'un pivot droit ou gauche.
Prévoir en outre : 6.042.929 - 1.
- 37** Opération à effectuer pour véhicules types R. 1060 - R. 1062 Grand Luxe et exportation U.S. : Percer 2 trous pour la fixation de la plaque de police.
Prévoir en outre : 5.537.830 - 1.
- 38** Opération à effectuer : fixer la plaque de police sur la face avant de la lame du pare-chocs en perçant 2 trous diamètre : 5,5 mm.
- 53** Opération à effectuer : Réduire la largeur de la bielle de 28 mm à 26 mm et sur chaque face, refaire les chanfreins de 1,5 mm à 45° (suivant feuille d'instruction n° 9.810.205).
- 57** 1. Sur demande, nous pratiquons l'échange à prix forfaitaire d'une bielle usagée contre une bielle remise à neuf (cote normale ou brut de réglage).
2. Suivant leur poids, les bielles sont classées en 2 catégories repérées par les lettres A ou B poinçonnées sur le corps de la bielle. Pour le remplacement d'un jeu de bielles de même catégorie, prévoir 4 bielles. Pour le remplacement d'une quantité inférieure à un jeu, prévoir des bielles de même catégorie que celles du moteur à réparer.
- 68** Jusqu'en décembre 1947, et après épuisement de 7.058.636 - 7.058.445 - 7.058.635.
Prévoir en outre : 7.058.669 - 1.
6.035.072 - 1.
- 70** Pour culasse ne comportant pas un trou taraudé de passage d'axe de culbuteur.
Prévoir en outre : 6.046.172 - 1.
- 71** Prévoir en outre : Opération à effectuer : Supprimer les coudes d'entrées d'air du filtre et du carburateur : 5.526.018 - 1.
- 73** Opération à effectuer : Aléser au diamètre : 6,5 mm les deux trous correspondant à ceux taraudés à 6 mm pas 1,00 sur la bride du corps de pompe à huile (suivant feuille d'instruction n° 5.540.649).
- 74** Opération à effectuer : Percer à 11,5 mm du centre de la turbine, un trou au diamètre : 2,5 mm pour le logement de l'extrémité du ressort (suivant feuille d'instruction n° 6.035.001 et 6.035.218).
Prévoir en outre : 6.035.218 - 1.



- 75** Pour véhicules équipés d'allumeurs à sorties de fils horizontales.
Prévoir en outre : 9.830.256 - 1.
9.830.730 - 1.
- 79** Opération à effectuer : Agrandir de 1,2 mm environ le diamètre de l'encoche pour le passage de l'ergot d'arrêt.
- 86** Opération à effectuer : Diminuer de 1,5 mm la longueur de l'embout de bielle de connexion en supprimant le chanfrein à 70°, côté portée sphérique (suivant feuille d'instruction n° 5.528.867).
- 93** Opération à effectuer : Ajuster la partie supérieure du cylindre de frein sur le plateau support de segments.
- 113** « Échange réparation » pour métropole.
- 113A** « Échange réparation » pour union Française et Exportation.
- 115** Lors du remplacement d'une pédale code JAEGER par une FERRAND.
Prévoir en outre : 8.232.525 - 1.
1.023.060.106 - 2.
1.081.300.656 - 2.
- 116** Précisez la marque de la dynamo à la commande.
- 119** Opération à effectuer : Raccourcir de 40 mm le tube côté réservoir.
- 143** Sur demande de deux sièges avant.
Prévoir en outre : 9.981.004 - 1.
9.981.003 - 1.
- 144** Sur demande de deux sièges avant.
Prévoir en outre : 9.981.004 - 1.
9.981.003 - 1.
- 149** Après épuisement des supports de pare-chocs n° 5.524.805 - 4.262.601 - 5.524.806 - 4.262.602 - 8.200.911.
Prévoir le pare-chocs complet.
- 154** Il a été monté sur véhicules R. 1060 et R. 2070, des allumeurs RB Ducellier - n° 8.511.931 - 8.513.910 et SEV n° 8.511.929 dont la fabrication est abandonnée, les remplacer par les allumeurs RB Ducellier n° 8.516.122 ou SEV n° 8.520.184.
- 155** Dans le cas du remplacement d'un contact ordinaire par contact ventilé.
Prévoir en outre : 8.537.314 - 1.
- 158** Pour (3) nous ne fournissons que les pièces de détail, la fabrication des ensembles équipant ces véhicules étant abandonnée.
- 161** Il a été monté sur véhicules R. 1060 - R. 1062 - R. 2070 - R. 2071, des phares Cibié type 3371 dont la fabrication est abandonnée ainsi que les phares Cibié type O-81 B et Cibié type 3370. Les remplacer par des phares Cibié type 311 B.
- 162** Il a été monté sur véhicules R. 1060 - R. 1062 - R. 2070 - R. 2071, des lanternes arrière latérales n° 8.515.224 et 8.515.225 dont la fabrication est abandonnée.
Les remplacer par les lanternes n° 8.517.773 et 8.517.774.
- 164** Après épuisement des anciens câblages, en rechange, il sera délivré seulement les derniers modèles de câblages pour les 2 genres de voiture :
- a) Avec batterie à l'avant :
Pour véhicules types R. 1060-R. 2070 et jusqu'au 283.715^e véhicule type R. 1062.
- b) Avec batterie à l'arrière :
A partir du 283.716^e véhicule type R. 1062 et pour véhicule type R. 2071.
- 166** Il a été monté en série un commutateur Super-multiplo dont la fabrication est abandonnée. Le remplacer par un commutateur Avercod Covir : 8.515.041 - 1.
- 168** Seulement pour véhicules équipés à l'origine d'une dynamo RENAULT ou Ducellier.
- 174** Pour coup de fouet sur moteur « échange réparation ».
- 185** Après épuisement de 9.909.254 - 9.909.255 - 9.909.634 - 9.909.635. Si les contrepoignées sont destinées à être montées sur une porte arrière remplacer la bielle de commande par la bielle de commande en votre possession et orienter après avoir retiré la goupille, le levier de commande avec son ressort dans la position voulue.
Remplacer la goupille ou commander suivant le cas.
- 186** Après épuisement de : 8.200.598 - 8.200.597 - 8.200.553 - 8.200.554 - 8.525.707 - 8.525.766 - 8.525.767, et pour véhicules équipés de sièges non réglables en marche.
Prévoir en outre : 8.535.270 - 1.
8.543.024 - 1.
6.052.048 - 1.
10.23.860.166 - 1.
10.81.300.656 - 1.
- 187** Prévoir en outre : 9.981.004/1 - 1.
- 188** Prévoir en outre : 9.926.003/4 - 1.



- 190** Opération à effectuer : Percer 2 trous de 12,5 mm pour fixation des interrupteurs.
Prévoir en outre : 8.526.445 - 1.
8.526.333 - 2.
7.062.170 - 2.
8.535.110 - 2.
- 192** Les voitures 4 CV sont équipées d'indicateurs de direction à flèches :
Jusqu'à la 3834^e caisse type R. 1060 : direction à gauche ;
Jusqu'à la 33^e caisse type R. 1060 : direction à droite ;
Jusqu'à la 447^e caisse type R. 2070.
Clignotants, avec commutateur de commande sur planche de bord :
De la 3835^e caisse type R. 1060 : direction à gauche du 64483^e véhicule ;
De la 34^e caisse type R. 1060 : direction à droite du 64484^e véhicule ;
De la 448^e caisse type R. 2070 du 8820^e véhicule.
Clignotants, avec commutateur de commande sur direction :
A partir du 64484^e véhicule type R. 1060, à partir du 8821^e véhicule type R. 2070. Pour véhicules types : R.1062 - R. 2071.
- 207** Pour véhicules antérieurs à 1956, prévoir la lanterne du côté opposé.
- 208** A partir de février 1956.
- 209** A partir de décembre 1956
- 212** Jusqu'en octobre 1956.
- 219** Après épuisement prévoir le dossier garni en blanc.
- 220** Peut se monter à partir des premiers véhicules, mais par paire.
- 224** Après épuisement de 8.526.568 - 8.526.884 - 8.526.511 - 8.526.883 - et pour véhicules équipés de sièges non réglables en marche.
Prévoir en outre : 8.540.689 - 1.
5.543.024 - 2.
6.052.048 - 1.
5.472.409 - 1.
5.472.681 - 1.
10.81.300.656 - 1.
6.057.093 - 1.
- 225** Opération à effectuer :
1. Brancher sur la borne : diamètre 5 mm, marquée BAT, le câble avec manchon blanc qui était sur la borne : diamètre 6 mm, marquée BAT.
2. Brancher sur la borne : diamètre 6 mm, marquée DYN, le câble avec manchon bleu qui était sur la borne : diamètre 5 mm marquée DYN.
Prévoir en outre : 8.518.340 et 8.526.623 - 1.
- 226** Jusqu'en janvier 1956 (tringlerie sans rotule nylon).
- 227** A partir de janvier 1956 (tringlerie avec rotule nylon).
- 228** L'adaptation de cette pièce nécessite le montage de : 9.803.563 - 4.
- 229** Après épuisement, prévoir : 9.803.747 - 4.
L'adaptation de cette pièce nécessite le montage de : 9.803.748 - 4.
- 230** Après épuisement, prévoir : 9.803.747 - 4.
L'adaptation de ces pièces nécessite le montage de 9.803.749 - 9.803.750 - 9.803.751 - 4.
- 231** Après épuisement de 8.237.090, l'adaptation de cette pièce nécessite le montage de : 7.036.113 - 1.
- 232** Jusqu'au 833.527^e véhicule et après épuisement de 8.237.651 et 8.213.242, l'adaptation de ces pièces nécessite le montage de : 5.542.829 - 1
- 233** Jusqu'au 734.319^e véhicule,
Prévoir en outre : 6.056.918 - 1.
- 234** Du 252.106^e au 634.187^e véhicule, l'adaptation de ces pièces nécessite le montage de :
8.236.175 - 1.
7.062.407 - 1.
- 235** Du 584.309^e au 872.576^e moteur, l'adaptation de cette pièce nécessite le montage de :
8.202.341/12 - 1.
6.034.067 - 2.
10.24.080.506 - 2.
10.80.120.850 - 2.
10.80.120.840 - 2.
- 238** Voir note R.S. 1255.
- 247** Après épuisement de 9.803.178 et jusqu'au 584.308^e moteur,
Fournir : 9.803.986.
- 249** Après épuisement de 9.803.179 et à partir du 584.309^e moteur,
Fournir : 9.803.987 - 1.
- 250** Non monté en série.
- 251** L'échange réparation de cet appareil est assuré à un prix forfaitaire pour les mécanismes de tous les modèles.



- 252** L'échange de réparation de cet appareil est assuré à un prix forfaitaire.
Le coffret rendu ne devra pas avoir son socle bakélite cassé ou fendu.
- 255** Pour R. 2071, après épuisement de 9.841.785, l'adaptation de cette pièce nécessite le montage de : 7.036.113 - 1.
- 259** Après épuisement, prévoir : 8.530.603 - 1.
- 260** Après épuisement de 8.530.581, jusqu'au 734.970^e véhicule, l'adaptation de cette pièce nécessite le montage de :
8.242.810 - 1.
10.23.060.166 - 2.
10.80.100.656 - 2.
- 266** Jusqu'au 877.487^e véhicule et après épuisement, l'adaptation de cette pièce nécessite le montage de : 6.066.553 - 1.
- 279** Et après épuisement de 8.536.326.
- 281** Et après épuisement de 8.543.436.
- 283** Et après épuisement de 8.539.611.
- 285** Et après épuisement de 8.543.435.
- 286** Jusqu'au 769.952^e véhicule sauf tropique et 841.460^e véhicule, tropique et après épuisement, prévoir : 8.235.252.
A partir du 769.953^e véhicule jusqu'au 841.460^e sauf tropiques, prévoir : 9.847.262.
- 289** Et après épuisement de : 8.236.175 et 8.237.281.
- 291** Et après épuisement de 8.236.174 et 8.237.288.
- 292** Jusqu'au 916.908^e moteur l'adaptation de cette pièce nécessite le montage de : 8.300.098 - 1.
- 293** Équipement facultatif.
- 294** Rappeler dans la commande l'inscription portée sur cette pièce.
- 318** Préciser le numéro de la clé.
- 319** L'adaptation de cette pièce nécessite le montage de :
5.544.105 - 1.
6.034.067 - 2.
6.069.082 - 2.
8.202.341 - 1.
9.811.906 - 1.
1.024.080.506 - 2.
1.080.120.840 - 2.
1.080.120.850 - 2.
- 320** Du 450.604^e VEH. au 872.576^e moteur, l'adaptation de cette pièce nécessite le montage de :
5.544.105 - 1.
6.069.482 - 2.
9.811.906 - 1.
- 321** Jusqu'au 872.576^e moteur, l'adaptation de cette pièce nécessite le montage de :
5.544.105 - 1.
6.069.482 - 2.
9.811.906 - 1.
- 322** Fournir échantillon de tissu.
- 323** Jusqu'à septembre 1960, l'adaptation de cette pièce nécessite le montage de : 8.546.203 - 1.
- 324** Pour corps supérieur 8.544.051.
- 325** Pour corps supérieur 8.546.202.

Édition	N°	Désignations technologiques	Édition	N°	Désignations technologiques	Édition	N°	Désignations technologiques
A	00.00	Page de garde	A	15.45	Fixation du carburateur et prise d'autostarter	A	19.00	Fixation de pompe à essence et canalisations
A	01.00	Sommaire			Carburateurs :			Pompe à essence :
A	02.00	Emplacement des numéros du véhicule et des organes	A	15.51	. . . 22 B.I.C.	A	19.01	. . . Guiot
A	03.00	Introduction. Utilisation du catalogue	A	15.53	. . . 22 I.A.C.	A	19.03	. . . S.E.V.
A	04.00	Renseignements généraux	A	15.55	. . . 22 I.C.B.T. sans correcteur	A	19.05	. . . d°
A	05.00	Signes et expressions codifiés	A	15.56	. . . 22 I.C.B.T. avec correcteur	A	19.07	. . . AC Delco
A	06.00	Consignes d'interchangeabilité	A	15.57	Tuyauterie de filtre à air	A	19.08	. . . d°
A	07.00	Répertoire des planches			Filtres à air :			Embrayage :
A	08.00	Numéros de fabrication de véhicules ou d'organes	A	15.58	. . . Compound	A	30.01	. . . Embrayage classique
		PIÈCES ET ENSEMBLES	A	15.59	. . . d°	A	30.03	. . . d°
		Moteur :	A	15.60	. . . Sec et à bain d'huile	A	30.05	. . . Embrayage Ferlec
A	14.01	. Moteur	A	16.01	. . . Pompe à huile	A	30.07	. . . d°
A	14.05	. . . Collection de joints	A	16.02	. . . d°	A	30.09	. . . Nécessaire de réparation Ferlec
A	14.07	. . . d°	A	17.00	. . . Collection de réparation de pompe à eau			Boîte-pont :
A	14.09	. . . d°	A	17.01	. . . Pompe à eau	A	31.01	. . . Boîtes-ponts assemblées
A	14.11	. . . d°	A	17.02	. . . d°	A	31.02	. . . d°
A	14.13	. . . Collection d'arrêtours	A	18.01	. . . Commande d'allumage	A	31.03	. . . Collection d'arrêtours
A	14.17	. . . Vilebrequin - Bielles - Pistons			Allumeur :	A	31.04	. . . d°
A	14.18	. . . d°	A	18.05	. . . R.B. Ducellier			. . . Carter et couvercles :
A	14.19	. . . Carters	A	18.06	. . . d°	A	31.11	. . . Type 3
A	14.20	. . . d°	A	18.07	. . . d°	A	31.12	. . . d°
A	14.21	. . . Jeux de chemises et de pistons	A	18.08	. . . d°	A	31.13	. . . Type 289
A	14.25	. . . Collections pour adaptation du carter	A	18.09	. . . d°	A	31.15	. . . Types 314-11, 314-17
A	15.10	. . . Culasses - Collecteurs (R. 1060 - R. 2070)	A	18.10	. . . S.E.V.	A	31.16	. . . Types 314-31, 314-35
A	15.11	. . . Culasse (R. 1062 - R. 2071)	A	18.11	. . . d°			. . . Pignonnerie :
A	15.12	. . . Collecteur Autobleu	A	18.12	. . . d°	A	31.17	. . . Type 3
A	15.13	. . . Collecteurs (R. 1062 - R. 2071)	A	18.13	. . . d°	A	31.18	. . . d°
A	15.40	. . . Arbre à cames	A	18.14	. . . d°	A	31.19	. . . Type 289
A	15.41	. . . d°	A	18.15	. . . d°	A	31.21	. . . Type 314
			A	18.16	. . . d°			. . . Commande des baladeurs et de l'embrayage :
			A	18.17	. . . d°	A	31.23	. . . Type 3
					Dynamo :	A	31.24	. . . d°
			A	18.20	. . . Renault	A	31.25	. . . Type 289
			A	18.22	. . . Ducellier	A	31.27	. . . Type 314
			A	18.24	. . . d°	A	31.31	. . . Différentiel et cardans
			A	18.26	. . . d°	A	31.32	. . . d°
			A	18.28	. . . d°	A	31.33	. . . d°
			A	18.30	. . . Paris-Rhône	A	31.34	. . . Collection de joints pour boîte-pont
			A	18.32	. . . Fixation et courroie de dynamo			
					Démarrreur :			
			A	18.34	. . . Renault			
			A	18.36	. . . Paris-Rhône			
			A	18.38	. . . Ducellier			
			A	18.40	. . . d°			

Édition	N°	Désignations technologiques	Édition	N°	Désignations technologiques	Édition	N°	Désignations technologiques
		Direction :						
A	40.05	. Direction	A	43.30	. Boîtes d'accessoires pour cylindres de roues arrière	A	62.05	. Lanternes arrière
A	40.06	. d°	A	43.35	. Moyeux et tambours arrière	A	62.07	. d°
A	40.07	. d°	A	43.36	. d°	A	62.09	. Lanterne de plaque de police
A	40.20	. Bielles de commande et volant de direction				A	62.11	. Tableau de bord
A	40.21	. d°	A	44.01	Roues	A	62.12	. d°
		Train avant :				A	62.13	. d°
A	42.01	. Train avant - Ensembles				A	62.14	. d°
A	42.03	. Fusées				A	62.15	. d°
A	42.04	. d°				A	62.16	. d°
A	42.05	. d°				A	62.17	. d°
		. Collections de réparation :				A	62.18	. d°
A	42.07	. . Pivots de fusées				A	62.19	. d°
A	42.09	. . . rtiulations de suspension	A	51.01	. Suspension avant	A	62.20	. Équipement électrique de la planche de bord
A	42.10	. Articulations de suspension avant	A	51.02	. d°	A	62.21	. d°
A	42.11	. d°	A	51.03	. Suspension arrière			. Indicateurs latéraux :
A	42.12	. d°	A	51.04	. d°	A	62.25	. . Scintex - Klaxon
A	42.13	. d°	A	51.05	. Suspension du moteur	A	62.26	. . Scintex
A	42.14	. d°	A	51.10	. Barre de torsion	A	62.27	. . Prelyo
A	42.15	. Nécessaires de réparation pour cylindres de roues avant	A	51.12	. Amortisseurs	A	62.28	. d°
A	42.17	. Boîtes d'accessoires pour cylindres de roues avant	A	51.14	. d°	A	62.29	. d°
A	42.19	. Freins avant	A	51.16	. d°	A	62.31	. . LMP - SWF
A	42.21	. d°				A	62.33	. Plafonniers et éclairer de capot
A	42.23	. Moyeux et tambours avant						. Essuie-vitre :
A	42.24	. d°						. . S.E.V. :
		Train arrière :				A	62.35	. . .
A	43.01	. Ensembles de train arrière				A	62.36	. d°
A	43.02	. d°				A	62.37	. d°
A	43.05	. Transmission de roues arrière				A	62.38	. . .
A	43.06	. d°				A	62.39	. d°
A	43.07	. Soufflets de protection des cardans				A	62.40	. d°
A	43.10	. Arbres de roues				A	62.41	. d°
A	43.15	. Freins arrière				A	62.42	. . Marchal
A	43.20	. d°						. . Moteur d'essuie-vitre :
A	43.21	. d°				A	62.43	. . . S.E.V.
A	43.25	. Nécessaires de réparation pour cylindres de roues arrière				A	62.44	. . . Marchal
								. Avertisseurs :
						A	62.50	. . Klaxon
						A	62.52	. d°
						A	62.54	. d°
						A	62.56	. . Ferson
						A	62.58	. d°
						A	62.60	. d°
						A	62.62	. . Ducellier
								. Projecteurs :
						A	62.01	. . Faisceau symétrique
						A	62.02	. . Faisceau asymétrique
						A	62.03	. . Projecteurs antibrouillard

08.00

A P.R. 685



1

R. 1062 n°

Table with 15 columns of numbers ranging from 23725 to 35003.

08.00

A P.R. 685



2

Table with 15 columns of numbers ranging from 35166 to 43213.

R. 1062 n°

Table with 15 columns of numbers ranging from 69931 to 71077.



3

R. 1062 n°

Table of numbers for R. 1062 n°, including rows for 187148, 189239, 190035, 190829, 190881, 191157, 191199, 191274, 191374, 191498, 192008, 192064, 192211, 192262, 192433, 192597, 192645, 193019, 193219, 193282, 193391, 193485, 193574, 193651, 193784, 245448, 248715, 248778, 248844, 248893, 248956, 249001, 249059, 249134, 249195, 249245, 249292, 249355, 249439, 249470, 249778, 249835, 249902, 249985, 250002, 250117, 250191, 250424, 251272, 251321



4

R. 1062 n°

Table of numbers for R. 1062 n°: 252109, 252241, 252114, 252323, 252128, 252459, 252131, 252466, 252143, 252145, 252158, 252195, 252218, 252234

5

R. 1062 n°

Table of numbers for R. 1062 n° with multiple columns: 5, 9, 10, 210, 214, 215, 223, 228, 235, 243, 253, 254, 260, 264, 266, 270, 273, 276, 290, 295, 298, 305, 309, 321, 323, 329, 330, 331, 333, 340, 346, 348, 356, 363, 364, 369, 372, 375, 377, 379, 387, 391, 400, 402, 407, 410, 420, 423, 427, 435, 438, 447, 451, 455, 466, 473, 478, 480, 487, 490, 491, 493, 507, 513, 517, 520, 533, 538, 538, 545, 547, 551, 552, 555, 556, 565, 568, 579, 581, 590, 592, 593, 604, 608, 620, 626, 628, 630, 637, 638, 641, 645, 646, 652, 670, 682, 684, 688, 697, 703, 712, 714, 723, 725, 731, 743, 751, 757, 762, 768, 776, 782, 789, 796, 798, 799, 803, 807, 808, 846, 847, 851, 863, 867, 874, 893, 894, 1837, 1838, 1847, 1850, 1855, 1859, 1865, 1868, 1869, 1875, 1884, 1894, 1898, 1903, 1911, 1920, 1924, 1925, 1931, 1935, 1938, 1943, 1947, 1948, 1972, 1978, 1982, 1983, 1985, 1994, 1998, 2176, 2180, 2184, 2190, 2197, 2204, 2205, 2210, 2219, 2222, 2225, 2231, 2234, 2243, 2249, 2252, 2253, 2261, 2262, 2264, 2265, 2271, 2272, 2276, 2284, 2285, 2299, 2302, 2308, 2313, 2316, 2318, 2324, 2328, 2330, 2331, 2339, 2340, 2342, 2347, 2349, 2350, 2353, 2360, 2364, 2376, 2386, 2388, 2396, 2399, 2403, 2407, 2414, 2417, 2425, 2428, 2431, 2434, 2439, 2441, 2442, 2446, 2455, 2457, 2459, 2461, 2468, 2475, 2476, 2479, 2483, 2487, 2497, 2502, 2504, 2509, 2510, 2517, 2520, 2523, 2532, 2533, 2536, 2546, 2549, 2553, 2555, 2558, 2567, 2577, 2585, 3587, 3590, 3592, 3598, 3601, 3606, 3608, 3613, 3618, 3619, 3625, 3639, 3641, 3643, 3648, 3664, 3667, 3674, 3679, 3683, 3688, 3689, 3694, 3695, 3700, 3703, 3708, 3715, 3716, 3722, 3725, 3728, 3730, 3731, 3736, 3739, 3743, 3754, 3760, 3764, 3769, 3770, 3772, 3775, 3778, 3788, 3791, 3799, 3805, 3807, 3810, 3812, 3815, 3834, 3838, 3841, 3854, 3857, 3858, 3862, 3866, 3872, 3873, 3874, 3877, 3885, 3886, 3888, 3889, 3893, 3894, 3900, 3907, 3915, 3919, 3923, 3924, 3927, 3929, 3935, 3945, 3950, 3953, 3956, 3959, 3962, 3967, 3968, 3977, 3986, 3988, 4179, 4180, 4182, 4184, 4195, 4197, 4202, 4220, 4223, 4239, 4243, 4245, 4247, 4248, 4254, 4255, 4258, 4259, 4262, 4263, 4268, 4275, 4279, 4281, 4282, 4288, 4289, 4291, 4306, 4307, 7077, 7084, 7088, 7089, 7102, 7103, 7105, 7106, 7111, 7114, 7118, 7123, 7125, 7138, 7141, 7144, 7149, 7153, 7155, 7158, 7167, 7174, 7178, 7189, 7190, 7196, 7197, 7199, 7204, 7206, 7213, 7217, 7226, 7227, 7234, 7239, 7241, 7245, 7249, 7260, 7261, 7263, 7265

08.00

A P.R. 685

**6****R. 1060 n°**

28231 ⇨ 28246 28248 ⇨ 28251 28253 ⇨ 28265 28268 ⇨ 28275 28277 ⇨ 28309
 28311 ⇨ 28312 28314 ⇨ 28322 28325
 3607 ⇨ 3611 3620 ⇨ 3622

7**R. 1060 n°**

108744 ⇨ 108799 108981 ⇨ 108999
 109000 ⇨ 109008 109301 109313 109317 109333 ⇨ 109388 109390 ⇨ 109436
 109438 ⇨ 109461 109464 ⇨ 109537
 110534 ⇨ 110544 110545 ⇨ 110578 110580 ⇨ 110604 110606 ⇨ 110619 110621 ⇨ 110628
 110630 ⇨ 110632 110635 ⇨ 110642
 112283 ⇨ 112299 112301 ⇨ 112311 112313 ⇨ 112316 112318 ⇨ 112327 112329 ⇨ 112366
 112471
 122813 ⇨ 122832 122834 ⇨ 122852 122854 ⇨ 122862 122864 ⇨ 122951 122953 ⇨ 122999
 123000 ⇨ 123011 123534 ⇨ 123557 123560 ⇨ 123787 123799 ⇨ 123825
 139426 139428 ⇨ 139432 139434 139438 ⇨ 139444

R. 2070 n°

10063 10064 10073 ⇨ 10077 10104 ⇨ 10106 10155 ⇨ 10158 10449 10450
 10471 ⇨ 10479

8**R. 1060 n°**

105354 105410 ⇨ 105999
 106000 ⇨ 106999
 107000 ⇨ 107999
 108000 ⇨ 108999
 109000 ⇨ 109999
 110000 ⇨ 110999
 111000 ⇨ 111999
 112000 ⇨ 112999
 113000 ⇨ 113999
 114000 ⇨ 114993
 115042 ⇨ 115174 115273 ⇨ 115687 115757 ⇨ 115999
 116000 ⇨ 116095 116284 ⇨ 116718 116904 ⇨ 116999
 117000 ⇨ 117427
 121810 ⇨ 121824

R. 2070 n°

9962 9965 ⇨ 9999
 10000 ⇨ 10231 10234 ⇨ 10238 10241 ⇨ 10248 10250 ⇨ 10258 10264 ⇨ 10276
 10283 ⇨ 10289

3

**9****R. 1062 n°**

329853
 352862 352864 ⇨ 352900
 354115 354122 354126 354137 354138 354140 354143 354145 354149 354150
 354154 354160 354162 354168 354180 354205 354225 354228 354234 354237
 354240 ⇨ 354242 354247 354250 354252 ⇨ 354254 354257 ⇨ 354260 354263 ⇨ 354266
 354268 ⇨ 354271 354273 354279 354282 354283 354285 ⇨ 354292 354294 354296
 354297 354299 354300 354302 354306 354308 354311 354312 354314 354315
 354317 354318 354320 354321 354324 354327 354328 354333 354335 ⇨ 354338
 354340 ⇨ 354344 354349 354350 354354 ⇨ 354358 354360 ⇨ 354363 354365 ⇨ 354369
 354371 354372 354274 354377 354378 354380 354385 354387 ⇨ 354389 354391
 354392 354394 354396 354399 ⇨ 354405 354407 ⇨ 354416 354418 354419 354420
 354422 ⇨ 354426 354428 354430 ⇨ 354438 354441 ⇨ 354450

10**R. 1060 n°**

105355 ⇨ 105409
 114994 ⇨ 114999
 115000 ⇨ 115041 115175 ⇨ 115272 115688 ⇨ 115756
 116096 ⇨ 116283 116719 116903
 117428 ⇨ 117999
 118000 ⇨ 118999
 119000 ⇨ 119999
 120000 ⇨ 120999
 121000 ⇨ 121809 121825

R. 2070 n°

9963 9964
 10232 10233 10239 10240 10249 10259 ⇨ 10263 10277 ⇨ 10282 10290

11**R. 1060 n°**

95116 ⇨ 95200 95376 ⇨ 95457 95461 95481
 98698 ⇨ 98814

R. 2070 n°

9676 9678 9679 9764 ⇨ 9766

12**R. 1060 n°**

121034 121837
 122005 ⇨ 122041 122043 ⇨ 122102
 139483 139485 ⇨ 139488 139490 139492 139495 ⇨ 139500 139502 139506 139507
 139509 ⇨ 139513 139515 ⇨ 139517 139519 ⇨ 139525 139527 ⇨ 139534 139537 ⇨ 139547
 139549 139551 ⇨ 139560 139562 ⇨ 139565 139567 ⇨ 139577

R. 2070 n°

10425 11000 ⇨ 11006



13

R. 1062 n°

57963 ⇨ 57966 57973 57975 ⇨ 57977 57979 57981
58001 58004 58010 58018 58026 58029 ⇨ 58032 58034 ⇨ 58038
58040 ⇨ 58042 58044 58045 58048 ⇨ 58050 58052 58054 ⇨ 58056 ⇨ 58061
58063 58065 58066 58069 ⇨ 58074 58077 58088 58090 58091 58095
58096 ⇨ 58101 58108 58110 58113 58114 58116 ⇨ 58120 58132 58134
58137 58139 58142 ⇨ 58148 58150 58153 58155 58164 ⇨ 58166 58182
58184 58185 58187 58188 58191 58192 58194 ⇨ 58196 58199 ⇨ 58201
58212 58214 58218 58219 58221 58223 58224 58226 ⇨ 58231 58235
58237 58238 58246 58248 58273 58275 58280 58288 58294 58303
58307 58309 58317 58319 58321 58322 58325 58330 58331 58335
58339 58347 58435 58467 58469 ⇨ 58471 58473 ⇨ 58475 58483 58492
58495 58502 58506 58511 58515 58518 58524 58528 58563 58649

59192 59196 59200 59208 59210 59229 59230 59234 59240 59250
59252 59259 59260 59262 59272 59274 59277 59278 59297 59302
59303 59311 ⇨ 59314 59316 ⇨ 59319 59321 59322 59355 59600 59718
59723 59727 59730 59735 59742 59746 59799 59951 59955

60096 60100 60109 60116 60157

96829 ⇨ 96836 96838 ⇨ 96848 96851 ⇨ 96855 96857 ⇨ 96858 96860 96865
96866 96868 ⇨ 96872 96874 ⇨ 96880 96882 96902 96903 96905 ⇨ 96907
96909 ⇨ 96911 96914 ⇨ 96917 96919 96922 96924 ⇨ 96930 96932 96933
96935 96938 96941 ⇨ 96945 96948 ⇨ 96951 96953 ⇨ 96958 96960 96962
96964 ⇨ 96967 96969 96974 96975 96978 96979 96981 96982
96984 ⇨ 96990 96992 96993 96996

97000 97004 97006 ⇨ 97008 97010 97012 97014 97015 97020 97021
97024 ⇨ 97027 97029 ⇨ 97033 97035 97036 97038 ⇨ 97041 97044 97045
97047 ⇨ 97053 97056 ⇨ 97059 97061 97063 97064 ⇨ 97066 97067 97069
97072 97074 97075 97079 97081 ⇨ 97083 97087 ⇨ 97097 97099 97100
97102 ⇨ 97105 97107 ⇨ 97109 97111 ⇨ 97122 97124 ⇨ 97131 97134 ⇨ 97140
97142 ⇨ 97145 97148 ⇨ 97154 97179 97180 97182 ⇨ 97190 97192 ⇨ 97200
97202 ⇨ 97212 97214 ⇨ 97220 97224 ⇨ 97232 97234 ⇨ 97240 97242 ⇨ 97249
97251 ⇨ 97253 97255 ⇨ 97257 97259 ⇨ 97265 97276 ⇨ 97281 97283
97288 ⇨ 97290 97296 97511 ⇨ 97517 97519 ⇨ 97531 97535 97537 ⇨ 97539
97546 97548 ⇨ 97557 97572 97577 97589 ⇨ 97601 97603 97604
97617 ⇨ 97621 97625 97628 ⇨ 97633 97636 ⇨ 97642 97644 ⇨ 97649 97651
97656 97658 ⇨ 97664 97672 97680 ⇨ 97684 97687 97692 97699 97701
97703 97714 ⇨ 97718 97726 97730 ⇨ 97732 97735 97752 97760
97765 ⇨ 97767 97781 97820 97824 97825 97832 97835 97841 97842
97846 97850 97852 ⇨ 97854 97860 97865 97866 97879 97883
97890 ⇨ 97892 97894 97895 97897 ⇨ 97900 97922 97993 ⇨ 97997 97999

98000 ⇨ 98004 98006 ⇨ 98014 98016 98017 98020 98022 98053 ⇨ 98057
98059 98062 98064 98088 98090 ⇨ 98099 98102 ⇨ 98105 98196 98262
98343 98369 98370 98372 ⇨ 98376 98378 ⇨ 98382 98384 98386 ⇨ 98395
98397 ⇨ 98405 98431 98432 98437 98446 98451 ⇨ 98454 98457 98519
98592 98623 98626 98630 ⇨ 98632 98644 98652 98721 98722
98732 ⇨ 98740 98743 98744 98747 98750 98751 98753 ⇨ 98755 98773
98793 98800 ⇨ 98802 98805 ⇨ 98821 98823 ⇨ 98825 98842 98877 98890
98932 98940 ⇨ 98942 98944 98945 98964 98960 98981 98983 98985

99018 99065 ⇨ 99076 99298 99310 99397 99602 99725 99756 99762
99775 99950

100009 100048 100049 100063 100095 100135 100155 100188 100200 .../



14

100212 100246 100250 100587 100674 100830
101046
102309 102310 102321 102325 102390 102405 102407 ⇨ 102409 102411 102433
102434

R. 2071 n°

2225 ⇨ 2227 2230 2241
3167 3168 3173 3174 3176 ⇨ 3178 3180 3181 3185 3217
3218 3228 3230 3237 3238 3268

R. 1062 n°

23004 ⇨ 23006 23008 23013 23014 23016 23018 23019 23020 ⇨ 23025
23028 23029 23030 23031 23033 ⇨ 23036 23038 ⇨ 23048 23050 ⇨ 23061
23063 23065 ⇨ 23069 23070 ⇨ 23073 23086 23095 23097 ⇨ 23105 23110
23114 23116 23117 23120 ⇨ 23123 23127 ⇨ 23148 23150 ⇨ 23156
23158 ⇨ 23160 23162 23163 23166 23167 23170 23173 ⇨ 23187
23189 ⇨ 23200 23441 ⇨ 23445 23447 ⇨ 23473 23475 23481 23483 ⇨ 23497
23499 ⇨ 23503 23505 ⇨ 23508 23510 ⇨ 23518 23520 23521 23523 23524
23526 ⇨ 23569 23573 23576 23578 23580 23582 23584 23586 ⇨ 23588
23590 ⇨ 23607 23609 ⇨ 23612 23614 ⇨ 23616 23618
23640 ⇨ 23643 23645 ⇨ 23657 23659 23661 ⇨ 23685 23687 ⇨ 23704
23706 ⇨ 23708 23710 23712 ⇨ 23724 23726 ⇨ 23730 23733 ⇨ 23768 23770
23772 23774 ⇨ 23806 23808 ⇨ 23810 23813 ⇨ 23818 23820 ⇨ 23824 23829
23831 23833 23835 23836 23840 23843 ⇨ 23846 23848 ⇨ 23852 23855
23858 23860 23861 23863 23867 23869 ⇨ 23872 23874 ⇨ 23886 23913
23916 23918 23942 23944 23946 23947 23963 23968 23975
23986 ⇨ 23992 23996 ⇨ 23998

24000 24003 24022 24024 24025 24027 24029 24030 24106 24121
24150 24158 24161 24166 24177 24179 24209 24210 24227 24228
24230 24232 24295 24297 24301 24318 24319 24334 24339
24350 ⇨ 24352 24355 24455 24477 24489 24492 ⇨ 24494 24497 24499
24501 24502 24527 ⇨ 24530 24532 24543 24552 24553 24555 24556
24568 24570 ⇨ 24572 24577 24580 ⇨ 24584 24612 ⇨ 24614 24615 24617
24635 24639 24641 ⇨ 24646 24648 ⇨ 24650 24653 24660 24663 24664
24665 24667 24718 24739 24751 24844 24845 24906 24908 24909
24913 24915 24923 24955 ⇨ 24957 24959

25470 ⇨ 25474 25639 ⇨ 25642 25645 25646 25649 25942 25989 25970
25973

26104 ⇨ 26107 26113 26116 ⇨ 26118 26129 ⇨ 26131 26134 26135 26137
26138 ⇨ 26324 26327 ⇨ 26329 26354 26373 26375 26383

27084 27393 27395 27422 27425 27427 27581 27608 27615 27616
27618 27619 27620 27653 27654 27670 27672 27676 27677 27684
27686 27688 27694 27735 27739 27754 27780

28656 28998 28999
29000 ⇨ 29002 29004 29006 29008 29009 ⇨ 29012 29064 29410 29414 29446
29451 29464 29605 29964

31346 31347 31349 31350 31352 ⇨ 31354 31363 31372 31381 ⇨ 31384
31386 31389 ⇨ 31393 31395 ⇨ 31397 31399 31414 31415 31417 ⇨ 31420
31427 31428 31430 ⇨ 31432 31435 31438 31444 31456 31468 31480
31482 31486 31487 31490 31491 31498 31500
31506 31891 31894 31980 ⇨ 31984
32195 32196 32232 32233 ⇨ 32238 32240 ⇨ 32244 32347 ⇨ 32350 .../



14

R. 1062 n°
32369 32388 ⇨ 32390 32392 32394 32407 32642 32650
33456 ⇨ 33460 33484 33497 33498 33962 33963 33964 33967 33968
35385
R. 2071 n°
1109 1110 1111 1113 1114 1116 ⇨ 1131 1133 1134 1135
1139 1140 1147 1155 1162 1167 1168 1172 1233 1234
1291 1425 1454 1457 1458

15

R. 1060 n°
90606 90608 90610 ⇨ 90612 90614 ⇨ 90632 90634 90636 ⇨ 90641
90643 ⇨ 90646 90648 ⇨ 90653 90655 90656 90659 ⇨ 90664 90667 90670
90672 90674 90676 ⇨ 90680 90682 90686 90688 90695 90697 90700
90703 90704 90707 90709 90711 90713 ⇨ 90715 90719 ⇨ 90723 90725
90726 90728 90732 90734 90738 90752 ⇨ 90754 90757 90759 90764
90768 90770 ⇨ 90774 90775 90777 90783 90784 90787 90790 90795
90797 90811 90821 90826 90882 ⇨ 90884 90893 90894 90896 90899
90903 90909 90941 90954 90958 90959 90960 90964 90966 90968
90969 90972 90974 90975 90977 90980 90982 ⇨ 90985 90987 ⇨ 90989
90993 90994 90996 90999
91000 91005 91010 91011 91013 91017 91023 91086 91108 91153
91156 91159 91161 91163 91164 91167 91168

16

R. 1060 n°
28231 ⇨ 28246 28248 ⇨ 28251 28253 ⇨ 28265 28268 ⇨ 28275 28277 ⇨ 28309
28311 28312 28314 ⇨ 28322 28324 28325
108744 108799 108981 ⇨ 108999
109000 ⇨ 109008 109301 109313 109317 109333 ⇨ 109388 109390 ⇨ 109436
109438 ⇨ 109461 109464 ⇨ 109537
110066 ⇨ 110619 110621 ⇨ 110628 110630 ⇨ 110632 110635 110638 ⇨ 110642
112283 ⇨ 112299 112301 ⇨ 112311 112313 ⇨ 112316 112318 ⇨ 112327 112329 ⇨ 112366
112471
122813 ⇨ 122832 122834 ⇨ 122852 122854 ⇨ 122862 122864 ⇨ 122951 122953 ⇨ 122999
123000 ⇨ 123011 123534 ⇨ 123557 123560 ⇨ 123767 123799 ⇨ 123825
139426 139428 ⇨ 139432 139434 139438 ⇨ 139444

17

R. 1062 n°
257499 257501 257503 257504 257507 257510 ⇨ 257516 257518 257520 257528
257530 257532 257535 ⇨ 257537 257539 257542 257543 257545 257547 257550
257552 257555 257558 257558 257560 257564 257565 257567 257571 257576
257582 257585 257588 257589 257592 257593 257596 257599 257603 257604
257606 257611 257614 257616 257619 257620 257621 257625 257629 257634
257638 257641 257642 257645 257649 257650 257653 257654 257656
257659 ⇨ 257661 257673 257679 257680 257684 257693 257698 257699 257702
257708 257709 257749 257750 257874 257875
258006 258030 258032 258056 258335 258364 258377 258610 258789



18

R. 1062 n°
16199 16203 16205 16206 16598 16601 16603 16607 ⇨ 16609 16614
16617 16633 16699 16759 16761 16763 16765 16769 16771 16773
16775 16777 16779 16781 16786 16792 16796 16798 16800 16825
16858 16900
20695 20701 20704 20707 ⇨ 20710 20712 ⇨ 20714 20716 ⇨ 20748 20750
20751 20753 ⇨ 20782 20774 ⇨ 20779 20801 20803 ⇨ 20813 20815 ⇨ 20819
20821 ⇨ 20841 20844 ⇨ 20875 20878 20885 20929 20944 20946
21028

R. 2071 n°
1012 ⇨ 1017

19

R. 1060 n°
51278 51279 51282 ⇨ 51285 51287 51288 51290 ⇨ 51299 51301 ⇨ 51305
51307 51309 ⇨ 51311 51313 51318 51323 ⇨ 51325 51327 51330 51333
51336 ⇨ 51338 51340 51350 51352 ⇨ 51354 51356 ⇨ 51359 51363 51368
51373 51379 51386 51393 51394 51402 51405 51418 51446 51667
51670 51709 51714 51716 51790 51957
52137 52173 52181 52188 52205 52215 52296

20

R. 1060 n°
94837 94840 94842 94843 94845 94850 94852 94853 94855 94856
94859 94861 94863 94867 94868 94870 94872 94876 94877 94879
94880 94882 94894 94897 94898 94900 94901 94903 94906 94910
94911 94912 94915 94920 94922 94923 94926 ⇨ 94928 94930 94933
94934 94938 94937 94939 94943 94944 94951 94953 94955 94957
94958 94961 94964 94971 94995 94997 94998
95000 95019 95021 95038 95040 ⇨ 95043 95045 ⇨ 95051 95056 95063
95070 95887

21

R. 1062 n°
28446 28447 28450 ⇨ 28453 28456 ⇨ 28459 28461 28462 28464
28467 ⇨ 28472 28474 28475 28478 ⇨ 28483 28489 28491 ⇨ 28500 28503
28504 28507 28508 28511 28512 28514 ⇨ 28516 28518 ⇨ 28520
28524 ⇨ 28527 28530 ⇨ 28533 28535 28537 ⇨ 28544 28546 28548 ⇨ 28550
28552 28554 28558 28560 ⇨ 28562 28567 ⇨ 28569 28571 ⇨ 28574 28578
28580 28582 28583 28585 ⇨ 28587 28591 ⇨ 28593 28596 28598 ⇨ 28601
28604 28605 28607 ⇨ 28612 28616 ⇨ 28620 28622 28624 28626 28627
28629 ⇨ 28632 28635 ⇨ 28640 28642 ⇨ 28644 28646 ⇨ 28648 28650 28652
28653 28656 28663 28665 28667 ⇨ 28671 28673 28674 28676 ⇨ 28678
28681 ⇨ 28683 28686 ⇨ 28691 28694 ⇨ 28696 28698 ⇨ 28707 28709
28711 ⇨ 28714 28717 28719 28721 28724 28727 28731 28740 28752
28775 ⇨ 28777 28780
29094



22

R. 1062 - Essai n° 171 n°

Table with multiple columns of numbers, including rows like 345817 345850 345855 345858 345872 345873 345876 345879 345891 345892...

23

R. 1062 - Essai n° 65 n°

Table with multiple columns of numbers, including rows like 199380 199382 199392 199396 199466 201901 -> 201918 201920 201922 -> 201967 201969 -> 201999...



24

R. 1062 n°

Table with multiple columns of numbers, including rows like 377116 377121 377127 377132 377142 377158 377178 277191 377206 378518 387429 387436 387460 387475 387483 387496 387503 387509 387520 387534...



24

R. 1062

Table with 10 columns of numbers ranging from 390826 to 391979.

Table with 10 columns of numbers ranging from 392014 to 392925.

Table with 10 columns of numbers ranging from 393008 to 393874.

Table with 10 columns of numbers ranging from 394007 to 394858.

Table with 10 columns of numbers ranging from 395036 to 395778.

Table with 10 columns of numbers ranging from 396003 to 397529.

Table with 10 columns of numbers ranging from 397586 to 398834.

399060 399094 399097

25

R. 1062 n°

Table with 10 columns of numbers ranging from 449428 to 450602.

26

R. 1062 n°

Table with 10 columns of numbers ranging from 451308 to 452037.

27

R. 1062 n°

Table with 10 columns of numbers ranging from 461435 to 461715.





27

R. 1062 n°

463907 463912 463920 463927 463935 463936 463945 463947 463950 463956
463957 463960 463962 463963 463972 463975 463976 463989 463991 463999
464005 464026 464031 464032 464036 464037 464039 464040 464042 464043
464048 464050 464065 464079 464085 464087 464099 464116 464120 464122
464129 464131 464140 464161 464186 464192 464211 464215 464222 464254
465417 465638 465840 465841 465854 465864 465912

28

Rr 1062 n°

460526 460529 460534 460537 460542 460850 460943 460957
461099 461148 461149 461170 461181 461220

30

R. 1062 n°

475735
487838 487842 487844 487848 487853 487855 487860 487861 487984 487988
487996 487998 487999
488003 488092 488186
490567 490568 490574 490577 490579 490580 490585 490586
498536 498542 498600 498722 498724 498765 498794 498833 498904
499206 499300

31

R. 1062 n°

500030 500033 500035 500036 500040 500044 500050 500055 500067 500075
500088 500088 500096 500103 500109 500116 500121 500124 500134 500154
500156 500162 500164 500165 500169 500175 500176 500197 500200
500203 500364 500370 500374 500378 500386 500387 500389 500396 500406
500418
501402 501411 501422 501441 501454 501467 501471 501472 501481 501483
501492 501493 501495 501497 501498 501500 501502 501505 501518 501523
501525 501536 501538 501561 501563 501587 501591 501593 501595 501597
501598 501607 501615 501618 501621 501629 501631 501635 501650 501651
501656 501657 501659 501660 501671 501673 501684 501693 501704 501727
501734 501735 501737 501744 501746 501750 501758 501759 501766 501767
501829 501843 501855 501857 501860 501883 501884 501886 501887 501892
501893 501911 501924 501968 501987
502000 502005 502007 502013 502037 502038 502077 502104 502123 502132
502176 502180 502183 502188 502192 502198 502199 502201 502204
502208 502215 502217 502221 502231 502235 502237 502238 502241
502243 502246 602248 602250 602253 602255 602257 602258 602275 602284
502290 502291 502294 502296 502301 502306 502313 502316 502318



502320 502323 502325 502328 502331 502334 502338 502346 502379
502393 502396 502399 502401 502404 502406 502408 502409 502411 502413
502415 502419 502443 502450 502451 502465 502467 502508 502512 502526
502533 502541 502545 502570 502586 502587 502610 502622 502637 502653
502655 502657 502661 502662 502664 502671 502673 502677 502679 502682
502685 502687 502691 502693 502694 502696 502699 502703 502726 502730
502732 502739 502742 502744 502750 502752 502754 502755 502757 502758
502760 502763 502764 502767 502769 502780 502870 502871 502901 502902
502904 502906 502908 502912 502914 502917 502919 502933 502948 502961
502974

503900 503906 503923 503947 503971
504007 504034 504057 504059 504095 504125 504128 504146 504148 504176
504240 504414 504417 504492 504535 504536 504546 504548 504549 504553
504556 504573 504574 504577 504578 504583 504717 504770 504772 504815
504817 504872 504873 504918 504921 504943

505336 505339 505342 505429 505430 505432 505491 505514 505516 505528
505543 505546 505575 505587 505591
506873 506898 506904 506906 506908 506913 506950 506952

3

R. 1062 n°

531953 531999
532000 532651 532816

33

R. 1062 n°

552171 552173 552202
553145 553151 553153 553170 553172 553175 553177 553182 553184 553188
553190 553196 553198 553202 553204 553207 553209 553215 553217 553220
553222 553231 553233 553239 553241 553246 553248 553249 553251 553266
553268 553275 553277 553283 553285 553288 553290 553295 553297 553302
553305 553308 553310 553320 553322 553331 553333 553346 553348 553362
553364 553384 553386 553392 553394 553370 553412 553417 553419 553435
553437 553449 553452 553459 553462 553467 553469 553486 553489 553493
553495 553497 553515 553517 553526 553528 553534 553536 553542 553544
553546 553552 553554 553557 553559 553567 553569 553571 553574 553577
553579 553581 553584 553589 553591 553597 553599 553605 553607 553614
553616 553624 553626 553632 553634 553648 553650 553656 553658 553667
553669 553678 553680 553689 553691 553693 553698 553700 553705 553707
553711 553713 553719 553721 553723 553725 553734 553736 553738 553741
553743 553749 553751 553759 553761 553778 553781 553791 553793 553796
553798 553818 553820 553829 553831 553841 553843 553852 553854 553860
553862 553869 553871 553875 553877 553879 553882 553886 553888 553897
553899 553903
554403 554693

08.00

A P.R. 685

XXXX
00000**34**

R. 1062 n°

633986 ⇨ 633989 633994 633995
 634000 ⇨ 634004 634006 634007 634011 634012 634014 634015 634017 634019
 634020 634023 634026 634029 634032 ⇨ 634034 634036 ⇨ 634039 634041 634042
 634044 634045 634047 ⇨ 634050 634052 634053 634055 ⇨ 634057 634059 ⇨ 634061
 634063 634064 634066 634069 634070 634072 634073 634076 634077
 634079 ⇨ 634086 634088 ⇨ 634091 634093 ⇨ 634100 634102 ⇨ 634105 634107 634108
 634110 634111 634113 ⇨ 634115 634117 ⇨ 634126 634128 ⇨ 634133 634135 ⇨ 634145
 634147 634149 ⇨ 634182 634184 ⇨ 634186

35

R. 1062 n°

634205 634229 634241 634284 634288 634297 634315 634324 634325 634359
 634377 634409 634515 634570 634579
 635032 635056 635355

36

R. 1062 n°

499481 499514 499530 499548 499578 499601 499622 499624 499633 499653
 499662 499672 499691 499699 499734 499957
 500055 500124
 501657

37

Boite-Pont type 3 n°

8312 ⇨ 8541 8547 ⇨ 8595 8597 ⇨ 8999
 9000 ⇨ 9045 9047 ⇨ 9049 9051 ⇨ 9056 9058 ⇨ 9085 9087 ⇨ 9097
 9099 9100 9102 ⇨ 9107 9109 ⇨ 9184 9186 ⇨ 9200 9202 9203
 9205 9206 9209 ⇨ 9213 9215 ⇨ 9226 9228 ⇨ 9245 9247 ⇨ 9848
 11723 ⇨ 11754

38

R. 1062 n°

28446 28447 28450 ⇨ 28453 28456 ⇨ 28459 28461 28462 28464
 28467 ⇨ 28472 28474 28475 28478 ⇨ 28483 28489 28491 ⇨ 28500 28503
 28504 28507 28508 28511 28512 28514 ⇨ 28516 28518 ⇨ 28520
 28524 ⇨ 28527 28530 ⇨ 28533 28535 28537 ⇨ 28544 28546 28548 ⇨ 28550
 28552 28554 ⇨ 28558 28560 ⇨ 28562 28567 ⇨ 28569 28571 ⇨ 28574
 28578 ⇨ 28580 28582 28583 28585 ⇨ 28587 28591 ⇨ 28593 28596
 28598 ⇨ 28601 28604 28605 28607 ⇨ 28612 28616 ⇨ 28620 28622 28624
 28626 28627 28629 ⇨ 28632 28635 ⇨ 28640 28642 ⇨ 28644 28646 ⇨ 28648
 28650 28652 28653 28656 ⇨ 28663 28665 28667 ⇨ 28671 28673 28674
 28676 ⇨ 28678 28681 ⇨ 28683 28686 ⇨ 28691 28694 ⇨ 28696 28698 ⇨ 28707
 28709 28711 ⇨ 28714 28717 28719 28721 28724 28727 28731 28740
 28752 28775 ⇨ 28777 28780
 29094

9

XXXX
00000**39**

Moteurs type 662-1 n°

35786 ⇨ 35797
 39942 39993
 40055 40701 ⇨ 40820
 55336 ⇨ 55425 55586 ⇨ 55775 55928 ⇨ 55999
 56000 ⇨ 56090 56187 ⇨ 56300

40

Moteurs type 662-1 n°

35798 ⇨ 35999
 36000 ⇨ 36999
 37000 ⇨ 37999
 38000 ⇨ 38999
 39000 ⇨ 39941 39945 ⇨ 39992 39994 ⇨ 39999
 40000 ⇨ 40054 40056 ⇨ 40700 40821 ⇨ 55335 55426 55585 55776 ⇨ 55925
 56091 ⇨ 55186 56301 ⇨ 58900

41

Moteurs type 662-2 n°

53031 ⇨ 53078 53132 ⇨ 53512 53525 ⇨ 53999
 54000 ⇨ 54142
 56131 ⇨ 56724 56741 ⇨ 57003
 58001 ⇨ 61000
 62001 ⇨ 66000 67001 ⇨ 67929 143737 ⇨ 143999 144000

42

Moteurs type 662-2 n°

53079 ⇨ 53131 53513 ⇨ 53524
 54143 ⇨ 54999
 55000 ⇨ 55999
 56000 ⇨ 56130 56725 ⇨ 56740
 57001 ⇨ 58000
 61001 ⇨ 62000
 66001 ⇨ 67000 67930 ⇨ 143736
 144001 ⇨ 144450

43

Moteurs type 662-1 n°

69500 69524 69651 69762
 70002 70032 70351 70365 70370 70395 70487 70508 70996
 71092 71294

08.00

A P.R. 685

08.00

A P.R. 685

XXXX
0000**44**

R. 1060 n°

94837	94840	94842	94843	94845	94850	94852	94853	94855	94856
94859	94861	94863	94867	94868	94870	94872	94876	94877	94879
94880	94882	94887	94892	94894	94897	94898	94900	94901	94903
94906	94910	94911	94912	94915	94920	94922	94926	94927	94928
94930	94933	94934	94936	94937	94939	94943	94944	94951	94953
94955	94957	94958	94961	94964	94971	94995	94997	94998	
95000	95019	95021	95038	95040	95041	95042	95043	95045	95046
95047	95048	95050	95051	95056	95063	95070			

45

Moteurs type 662-2 n°

104590⇒104800
110001⇒110731
228671⇒228767
229285⇒229999
230000 230370⇒230841

46

Moteurs type 662-2 n°

104801⇒110000 110732⇒228670 228768⇒229284
230001⇒230369 230842⇒230930

47

R. 1062 n°

192505
193845 193873 193930
194023 194147 194151 194155 194157 194768 194770 194774

48

Moteurs type 662-2 n°

205537
209000 209361⇒305620
307314⇒307353 307508 307527⇒341242

49

Boites-Ponts type 3 n°

237984⇒237989
238291⇒238296 238457⇒238492 238657⇒238681
239582⇒239626
240008⇒240058
272696⇒274164
275091⇒275500 276644⇒281584
282716⇒283050 283229⇒286365 286918⇒288107

10

XXXX
0000**50**

R. 1062 n°

239717⇒240000 240733
302584 302901⇒302999
303000⇒303999
304000⇒304548

51

R. 1062 n°

240001⇒240732
302855⇒302900
304549⇒396438

52

R. 1062 n°

240739 240299 240809 240812 240814 240839
241015 241018 241044 241046 241047 241140 241172 241192 241281
241432⇒241436 241445⇒241447 241456 241461 241467 241468 241471 241476
241482 241484 241489 241496 241504 241635 241636 241642 241647 241650
241651 241652 241657 241672 241679 241681 241819 241956

53

R. 1062

302857
304564 304573 304604 304658 304660⇒304663 304665⇒304667 304669⇒304673
304675⇒304678 304680⇒304683 304685 304688 304688⇒304698 304698 304700
304703⇒304706 304708 304711⇒304714 304716⇒304723 304725⇒304728
304731⇒304735 304737 304738 304740⇒304742 304746 304747 304749 304855
304929 304932 304997
305073 305226 305287
340216 340223 340228 340229 340307 340318 340321 340323 340324 340341

54

Moteurs type 662-2 n°

305621⇒305999
306000⇒306999
307000⇒307313 307354⇒307507 307509⇒307526

55

Moteurs type 662-2 n°

307314⇒307353 307508 307527⇒341242

08.00

A P.R. 685

08.00

A P.R. 685

**56**

R. 1062 n°

328808↔328811 328813↔328819 328821 328822 328824 328828↔328830
 328832↔328836 328838↔328841 328843↔328848 328852↔328858 328860↔328862
 328864↔328868 328870↔328873 328877↔328879 328881↔328888 328891 328895
 328897 328898 328902↔328909 328911↔328914 328916↔328919 329078

57

R. 1062 n°

496491 496503 496530 496547 426556 496565 496603 496604 496617 496629
 496642

58

R. 1062 n°

441288↔441312 441314↔441352 441354↔441384 441386↔441397 441399↔441408
 441410↔441449 441452↔441467 441469↔441472 441474↔441489 441491↔441508
 441510↔441525 441527↔441531 441533↔441548 441550↔441557 441559
 441561↔441568 441570↔441579 441581↔441584 441586↔441589 441591↔441607
 441609↔441611 441613↔441627 441629↔441645 441647↔441651 441653↔441674
 441676↔441695 441697↔441744 441746 441751 441753↔441778 441780 441781
 441783↔441787 441789↔441791

59

R. 1060 n°

6723 ↔ 30271 30273 ↔ 32938 33552 ↔ 33554 33570 ↔ 33579

60

R. 1060 n°

468737↔468801 469774↔469911

61

R. 1060 n°

30273 ↔ 32938 33552 ↔ 33554 33570 ↔ 33579

62

R. 1062 n°

9676 9678 9679 9764 9765 9766
 10063 10064 10073 ↔ 10077 10104 ↔ 10106 10155 ↔ 10158 10449 10450
 10471 ↔ 10479

63

R. 1062 n°

192506↔193844 193846↔193872 193874↔193929 193931↔194022 194024↔194146
 194148↔194150 194152↔194154 194156 194158↔194767 194769 194771↔194773
 194775↔194782 194787 194792

11

**08.00**

A P.R. 685

64

R. 1062 n°

251601↔251623 251625 251626 251628↔251633 251636 252001↔252104

65

R. 1062 n°

251340↔251600 251624 251627 251634 251635 251637↔252000 252105↔257307
 257309↔257487 257489↔257496

66

R. 1062 n°

432734 432737 432763 432882 432891 432977 432982 432985

67

R. 1060 n°

39057 39869 39875 39882 39899 39909 39915 39930 39954 39963
 40040 41300

68

R. 1062 n°

201601↔201899
 202001↔202399 202801↔203632

69

R. 1062 n°

201403↔201600 201900↔202000 202400↔202800

70

R. 1062 n°

201403↔201600 201900↔202000 202400↔202800 203633↔224886
 225000↔225568

71

R. 1062 n°

47352 47380 47431 47433 47450 47465 47483 47503 47588 47675
 47669 47740 47756 47757 47813
 48107 48200 48210 48211 48220 48252 48261 48262 48265 48296
 48298 48381 48432 48433 48655 48678

72

R. 1062 n°

413225↔413600
 414680↔414689 414796 414805

08.00

A P.R. 685

XXXX
0000**73**

R. 1062 n°

525363 525422 525454 525565 525782
 527484 527493 527513 527514 527525 527535 527545 527608 527656
 528549 528571 528807 528840

74

R. 1050 n°

258534⇒258536 258538⇒258540 258542⇒258545 258548⇒258550 258552 258554
 258555 258557 258558 258565 258566 258568 258570 258574 258576 258581
 258582 258591 258595 258596 258599⇒258601 258603 258609 258610 258613
 258619 258621 258626 258628 258630 258631 258633 258634 258636 258641
 258652 258654 258660 258661 258678 258680 258690 258697 258754 258755
 258759 258762 258770 258773 258780 258783 258789 258794 258806 258808
 258818 258833 258839 258844 258853 258860 258865 258875 258882 258890
 258894 258902 258911 258921 258928 258941 258948 258958 258974 258986
 259000 259001 259010 259025 259026 259036

75

R. 1060 n°

335624⇒335626 335629 335630 335633⇒335635 335640 335643 335646 335648
 335650 335653 335654 335657 335660⇒335665 335668 335671 335672 335679
 335686 335687 335690 335693 335697⇒335700 335703 335711 335712 335719
 335725 335728 335731 335735 335738 335744 335745 335748 335751⇒335753
 335758 335761 335764 335770 335774 335777 335781 335782 335784 335787
 335791 335794 335797 335800 335804 335808 335811 335816⇒335818 335823
 335830 335833 335837⇒335839 335843 335847 335848 335852 335861 335877
 335878 335893 335901 335903⇒335957 335959 335960 335964 335968 335974
 335978 335986 335988 335992 335994 335997
 336347 336354 336371 336387 336389 336399 336448 336508

76

R. 1060 n°

110503 110504 110507 110528 110605 110831 110843

77

Moteurs type 662-1 n°

69500 69524 69762
 70002 70032 70351 70365 70370 70395 70487 70508 70996
 71072 71294

78

R. 1062 n°

599348⇒599499
 602680⇒602690
 614069⇒614246

12

XXXX
0000**79**

R. 1062 n°

612117

80

R. 2070 n°

6373

81

R. 1062 n°

57896

82

R. 2070 n°

9544 9547 9548 9551

83

R. 1062 n°

735638 735642 735650 735651 735661 735663 735667 735671 735682 735689
 735692 735697 735698 735700 735701 735703 735704 735706 735709 735712
 735714 735722 735725 735726 735728 735733 735736 735742 735753
 735759⇒735762 735769 735774 735783 735786 735787 735794 735800 735974
 735978 735984 735987 735992 735996

736004 736008⇒736010 736012 736014 736018 736022 736023 736035 736036
 736039⇒736041 736051 736054 736059 736062 736064 736066 736069⇒736071
 736077 736078 736081 736083 736088 736089 736092 736095 736099⇒736101
 736111 736116 736119 736123 736126 736135 736143 736145 736146 736152
 736156 736161 736164 736170 736174 736175 736177⇒736179 736182 736187
 736188 736190 736191 736193 736196 736200 736202 736204 736209 736214
 736217 736220 736222⇒736224 736226 736227 736229 736234 736236 736240
 736242 736250⇒736252 736255 736261 736262 736265 736266 736268 736274
 736275 736277⇒736279 736284 736288 736290 736293 736297 736304
 736306⇒736309 736311 736313 736315 736318 736320⇒736322 736328 736330
 736332 736334 736337 736338 736340 736343 736346 736349 736356⇒736358
 736360 736364 736365 736369 736374 736378⇒736380 736383 736385 736386
 736389 736393 736394 736399 736405⇒736407 736410 736414 736417 736418
 736420 736423 736430 736434 736435 736438⇒736440 736442 736444 736448
 736450 736453 736454 736466 736467 736471 736473 736480 736483 736484
 736487 736489 736491 736492 736493 736498⇒736500 736502 736503 736508
 736511 736516 736519 736521 736526 736528 736530 736531 736535 736536
 736538 736539 736548 736552 736553 736556 736558 736559 736561 736563
 736574 736577 736578 736580 736582 736583 736590⇒736592 736594
 736600⇒736602 736604 736606⇒736608 736612⇒736614 736625 736629 736631
 736633 736635 736638 736642 736643 736646 736650 736657 736659 736661
 736666 736668 736672 736674 736679⇒736681 736686 736693 736696 736705
 736713 736723 736778 736785 736793 736795 736801 736819 736907

08.00

A P.R. 685



83

R. 1062 n°

Table of numbers for R. 1062 n° with multiple columns of values.

84

Moteurs n°

Table of numbers for Moteurs n° with multiple columns of values.

85

R. 2070 n°

Table of numbers for R. 2070 n° with multiple columns of values.

86

VEH n°

Table of numbers for VEH n° with multiple columns of values.



Large table of numbers for various categories, including Boites-Ponts type 314 n°.

87

Boites-Ponts type 314 n°

Table of numbers for Boites-Ponts type 314 n° with multiple columns of values.

88

R. 2071 n°

3705

89

R. 2071 n°

3706

90

R. 2070 n°

4315

08.00

A P.R. 685

XXXX
00000

14

91

R. 2070 n°
4316

92

R. 1062 n°
921190 921220 921235 921373
922023 922034 922035 922068 922103 922186

93

R. 1062 n°
921287 921293 921342 921360 921492
922450 922455 922462 922904 923136

XXXX
00000

08.00

A P.R. 685

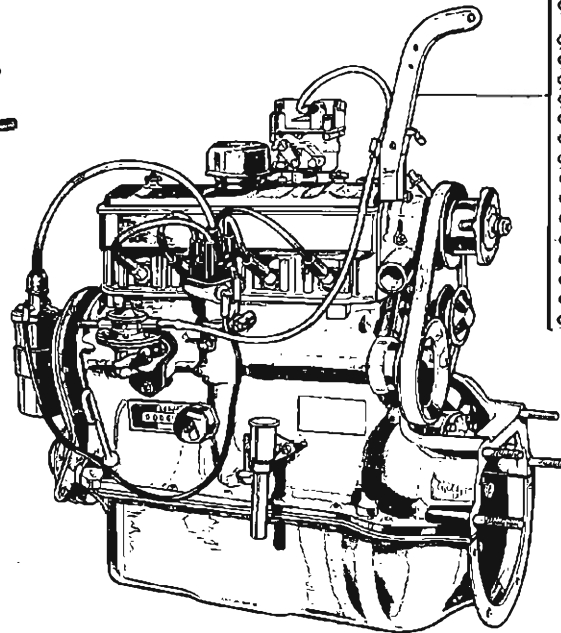
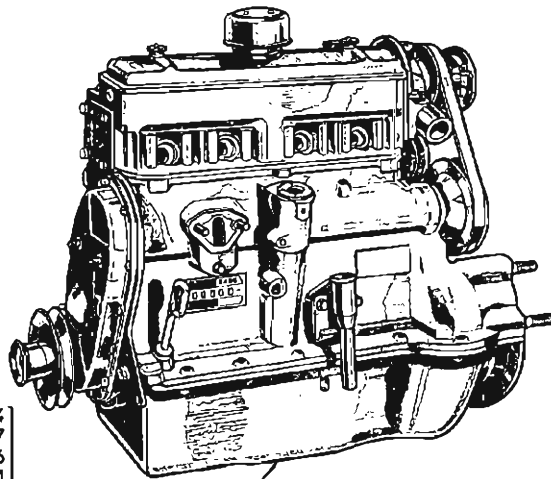



- † 9 810 364
- † 9 810 527
- † 9 810 526
- (q) 9 803 161
- (r) † 9 811 762
- 9 803 188
- (q) † 9 811 768
- † 9 803 162
- (r) † 9 811 772
- (u) † 9 803 103
- (e) 9 806 034
- † 9 811 852
- 9 803 163
- US † 9 803 487
- (w) 9 806 037

- 9 803 053 †
- 9 803 186 (a) ●
- 9 811 851 †
- 9 803 159 (a) } (b)
- 9 811 945 12 †
- 9 803 160 † (a) } (c)
- 9 803 486 † (d) } US
- 9 806 036 (f) }
- 9 810 523 †
- 9 810 522 † } (g)
- 9 803 156
- 9 811 763 † } (h)
- 9 803 157
- 9 811 944 12 † } (j)
- 9 803 158
- 9 811 767 † } (g)
- 9 803 185
- 9 811 771 † (k) } US
- 9 803 184 † (m)
- 9 803 183 † (n)
- 9 806 033 (p)
- 9 806 380 ●
- 9 806 383 △

FERLEC

US







XXXX
00000

25	 08-00
26	 08-00
32	 08-00

XXXX
00000

n°...		n°...	↗	↘	!!!
(a)					225
(b)	1 VEH	532892		32	
(c)	532893 VEH	...		32	
(d)	1 MOT	872575			
(e)	872576 MOT	...			
(f)	872576 MOT	...			235
(g)	1 VEH	450603	26	25	50 51
(h)	450604 VEH	532892	25	26	50 32 51
(i)	532893 VEH	...		32	50
(k)	450604 VEH	...	25	26	50 32
(m)	450604 VEH	MOT 584308	25	28	50 32 225
(n)	584309 MOT	872575			225
(p)	872576 MOT	...			235
(q)	1 VEH	450603	26	25	319
(r)	450604 VEH	...	25	26	
(u)	450604 VEH	MOT 872575			320
(w)	872576 MOT	...			321

!!!

50		8524402 -1- 8026144 -1-
51		8202341 -1- 6034087 -2- 1024 080506 -2- 1080 120850 -2- 1080 120840 -2-
225		 06-00
235		 06-00
319		 08-00
320		 06-00
321		 06-00



15-10
16-11

14-19
14-20

14-19
14-20
15-10
15-11
16-01
16-02

16-01
16-02

14-19
14-20

15-10
15-11

14-19
14-20

19-00

16-01
16-02

19-00

15-10
15-13

15-10
15-13

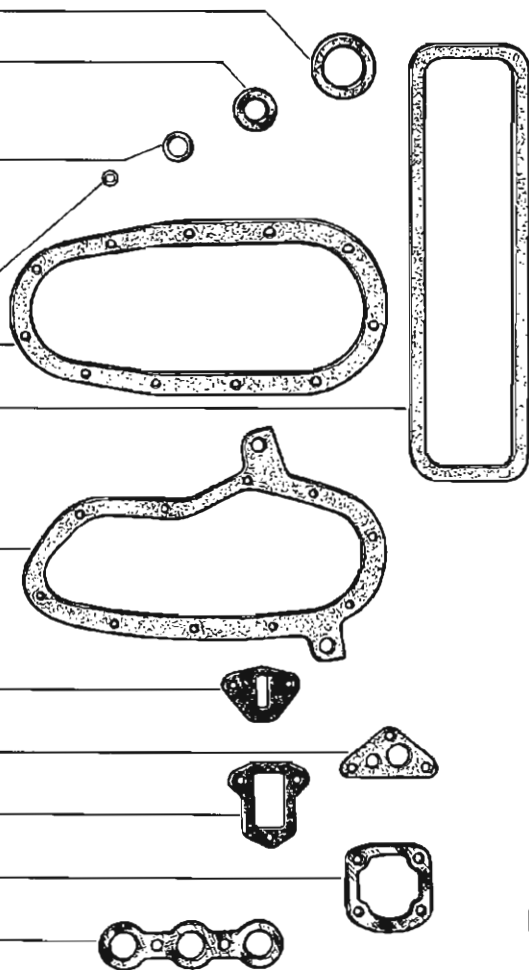

17-01
17-02

17-01
17-02

15-10
15-11

14-17
14-18

17-01
17-02

14-19
14-20

15-10
15-11

14-19
14-20

14-19
14-20

14-19
14-20

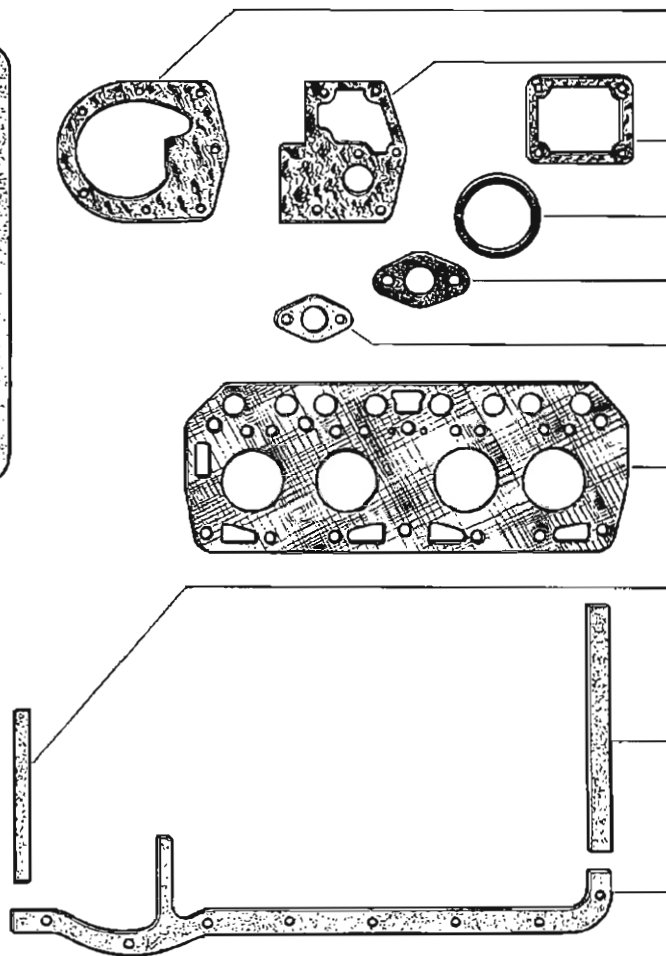

- (a) MOT n° 1 ⇨ MOT n° 791922
- (b) MOT n° 791923 ⇨ MOT n° ...
- (c) MOT n° 1 ⇨ MOT n° 521144
- (d) MOT n° 521145 ⇨ MOT n° 791922

- (a) † 9 803 351
- (b) † 9 803 738
- 9 803 900 Ⓢ 14-09
- (c) † 9 809 537
- (d) † 9 811 900
- (b) † 9 803 737
- 9 803 899 Ⓢ 14-07

US

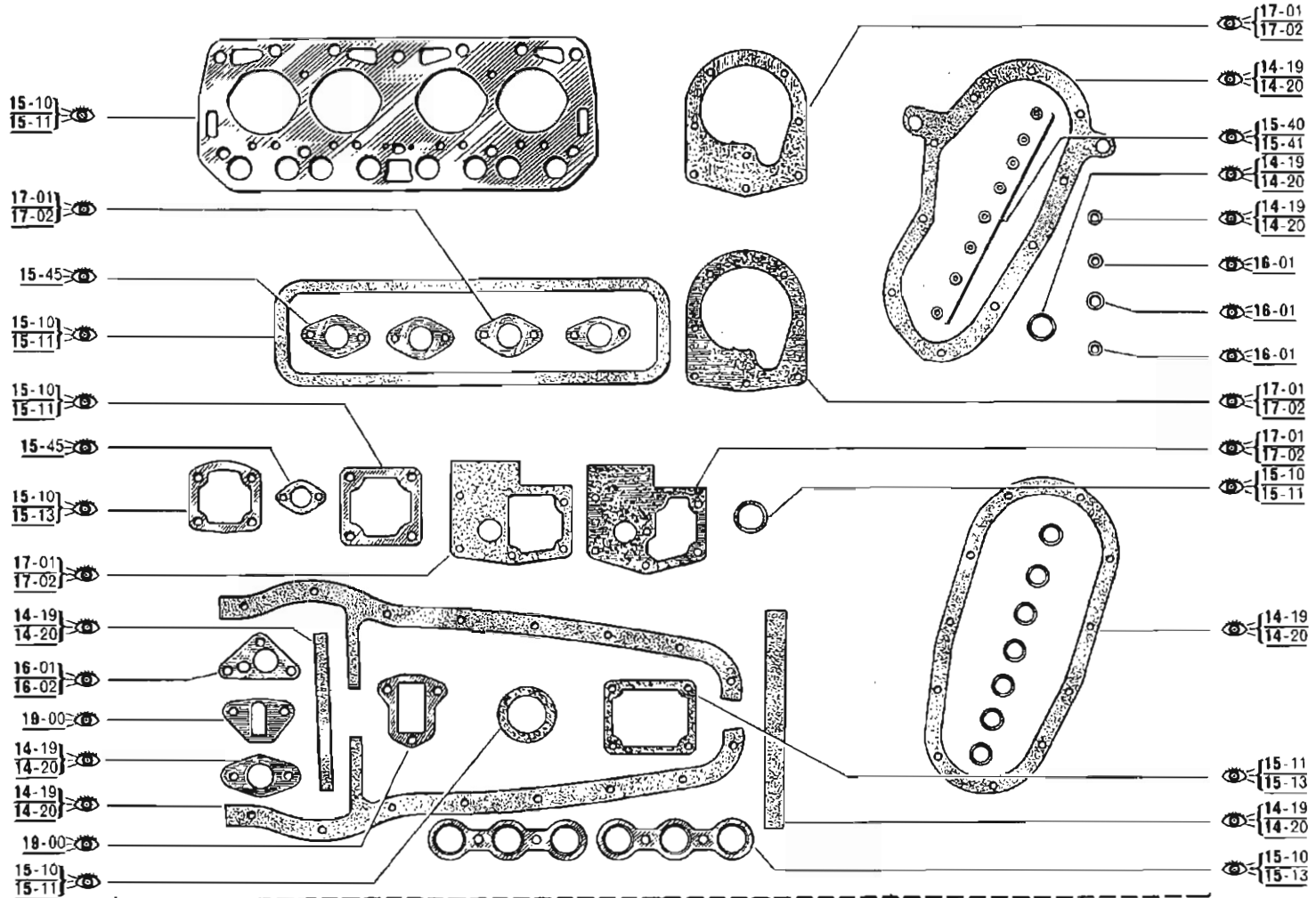

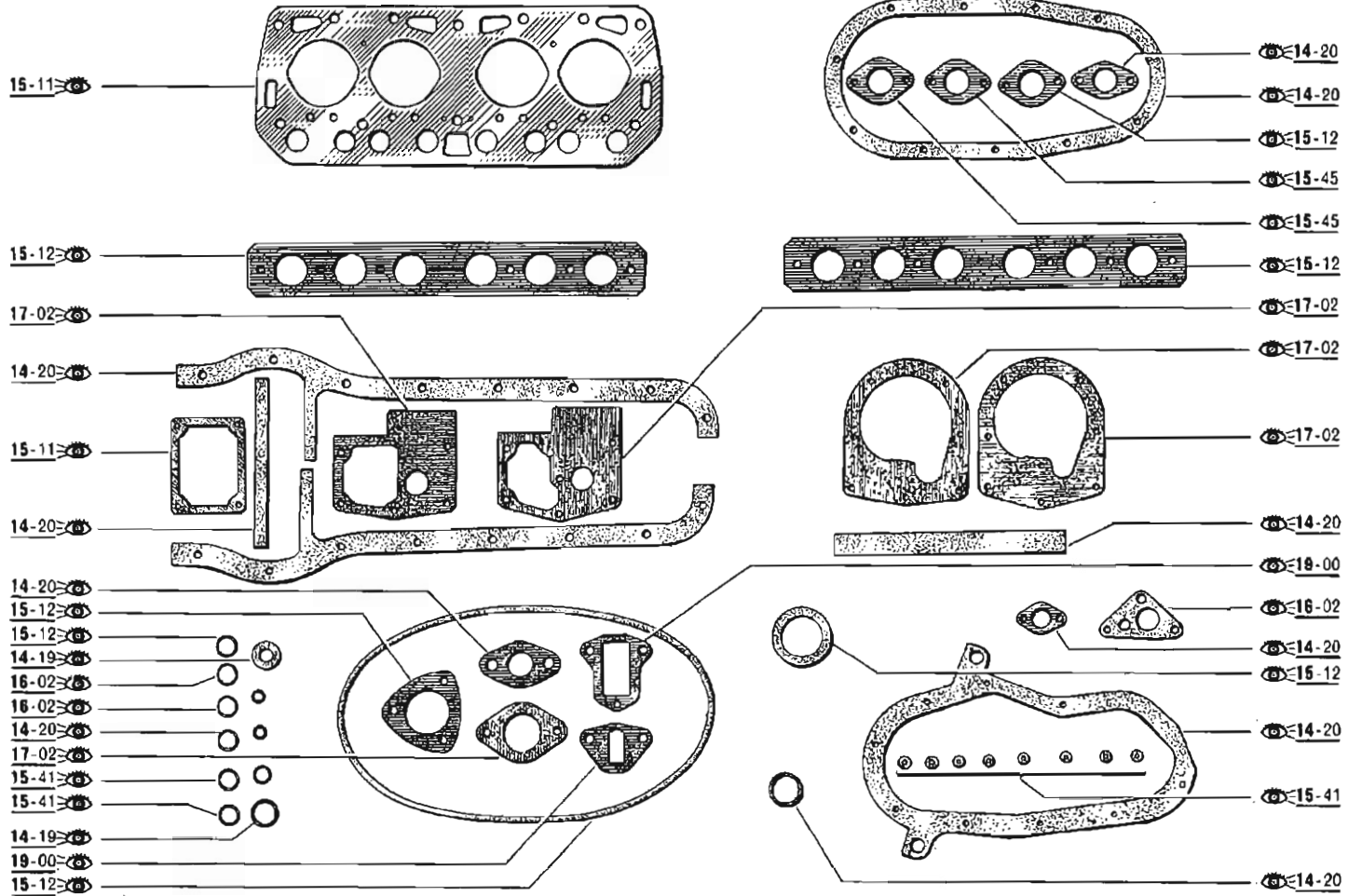

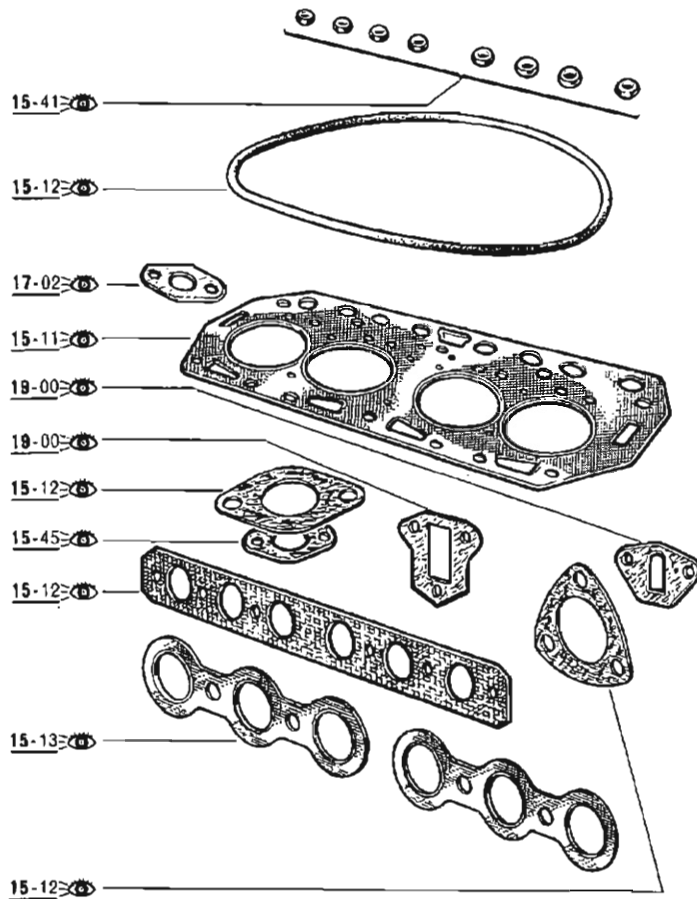

9 803 892 US

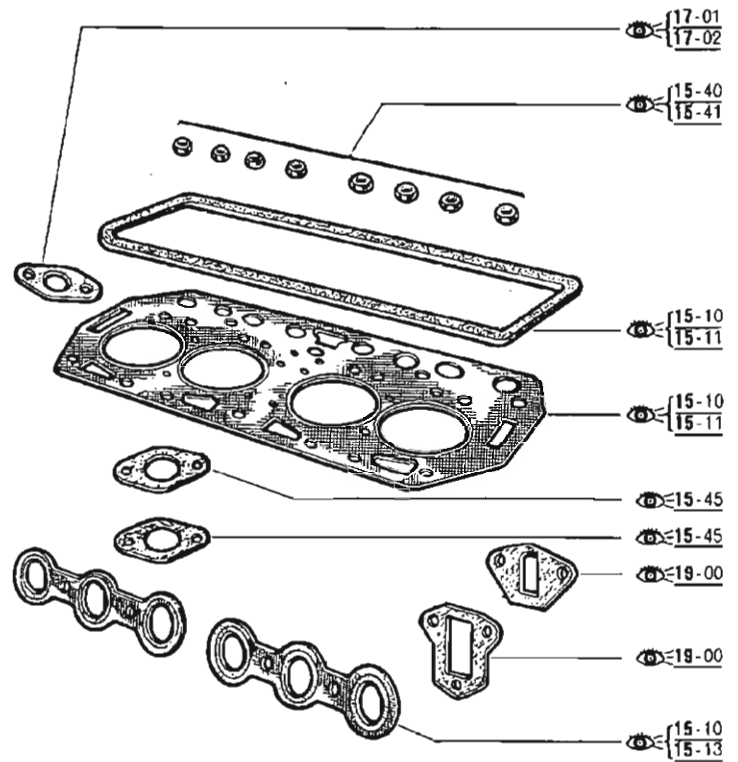

9 803 891

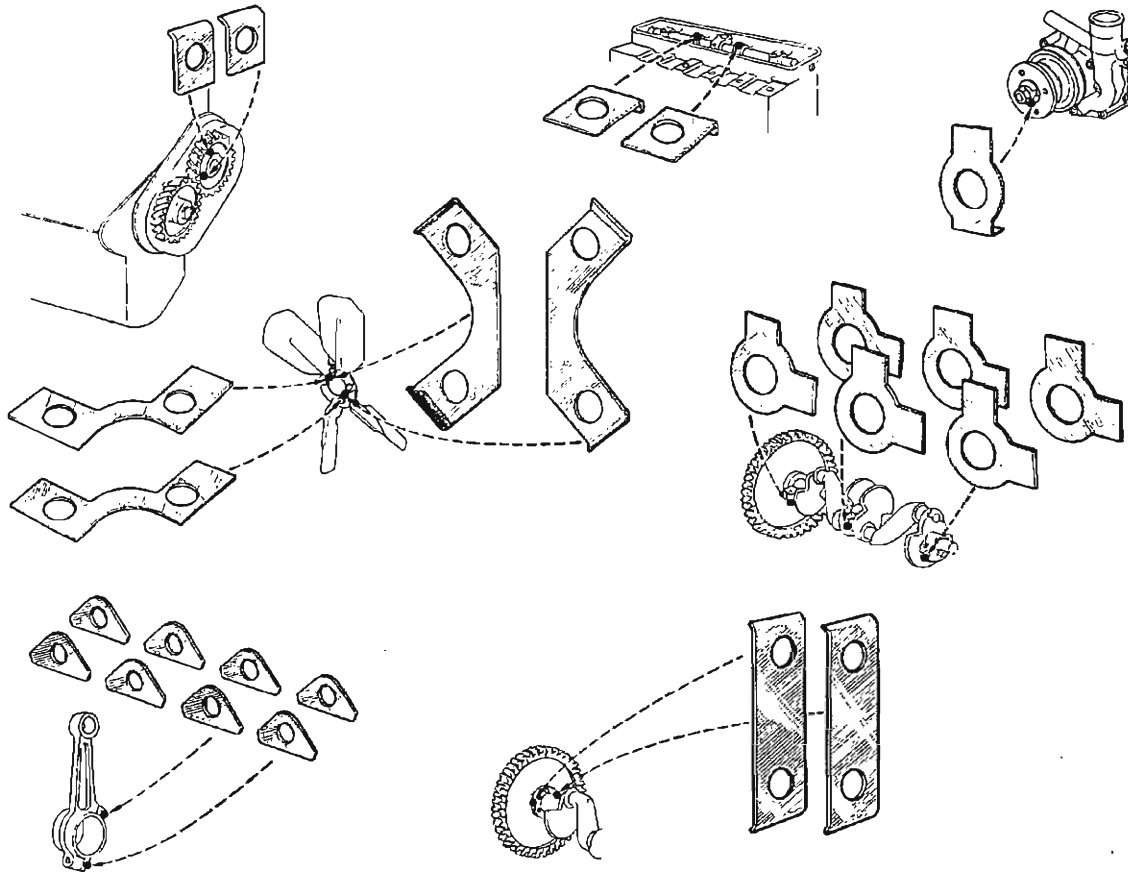

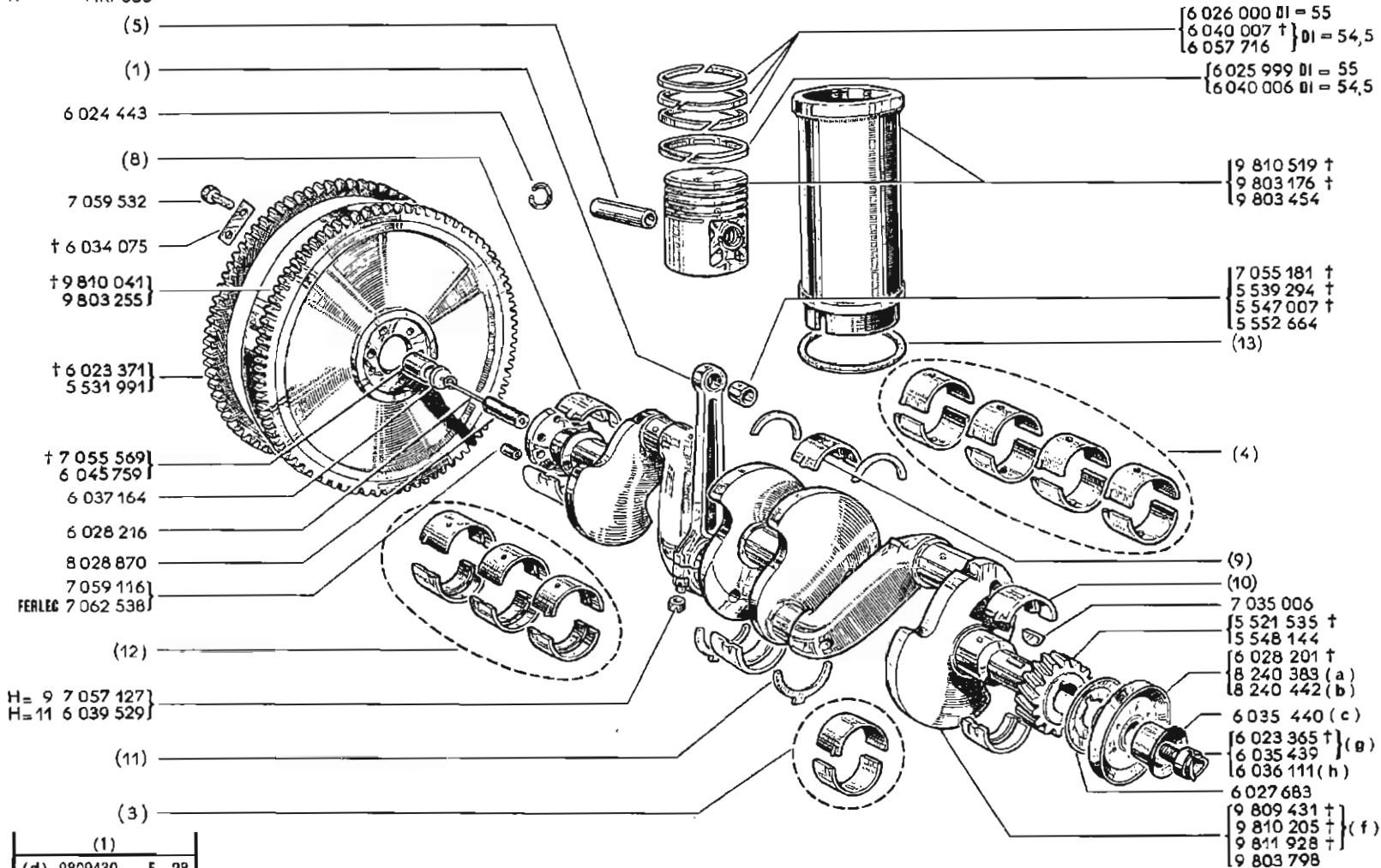

(1)	(d) 9809430	E = 28
	{ 9810062 †	
	(e) 9810344 †	E = 26
	{ 9803747	
	(d) 9809284	
	{ 9810281 †	
	(e) 9810398 †	E = 29
	{ 9803747	

(5)	(3)	(4)	(8)	(9)	(10)	(12)	(11)	(13)
6033998 †	9803748 †	9806087 DI = 35	9809429 †	9809428 †	9809427 †	9806094 DI = 40	9809426 E = 2	7058187 E = 0,95
6057133 †	9803749 †	9806086 DI = 34	9809506 †	9809509 †	9809512 †	9806091 DI = 39,75	9811974 E = 2,05	7058703 E = 0,90
7109141	9803750 †	9806085 DI = 34,5	9809507 †	9809510 †	9809513 †	9806092 DI = 39,5	9809515 E = 2,1	7109160 E = 1
7109142	9803751 †	9806084 DI = 34,75	9809508 †	9809511 †	9809514 †	9806093 DI = 39	9809516 E = 2,15	7109161 E = 1,05

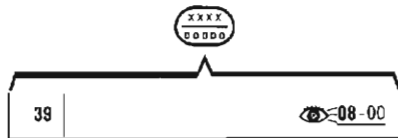

	n°...	→	n°...	↘	↙	!!!
(a)	1	MOT	35529			
(b)	35530	MOT	...			
(c)	950†	MOT	...			
(d)	1	MOT	58900	39		57
(e)	58901	MOT	...	39		57
(f)						53
(g)	1	MOT	35529			58
(h)	35530	MOT	...			58

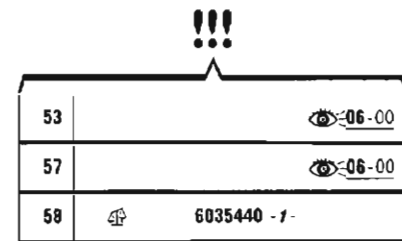

- (k) † 6 040 007
- (s) 6 057 716
- † 6 054 671
- (m) † 6 061 977
- † 6 054 650
- 6 061 650
- (1)
- 6 024 443
- 7 059 532
- FERLEC 7 062 083
- † 6 034 075
- (z) † 9 810 344
- † 9 810 398
- (aa) † 9 811 692
- (ab) † 9 811 692
- (11)
- (4)
- † 9 810 041
- 9 803 251
- (c) † 6 023 371
- 5 531 991
- (d) 5 542 712
- † 7 055 569
- 6 045 759
- (a) 6 037 164
- (a) 6 028 216
- (a) 8 028 870
- 7 059 116
- FERLEC 7 062 538
- (7)
- H = 9 7 057 127
- H = 11 6 039 529
- (f) 7 061 787
- (8)
- (f) † 6 051 559
- (f) † 6 051 561
- † 6 058 721
- † 6 058 722
- 7 062 599

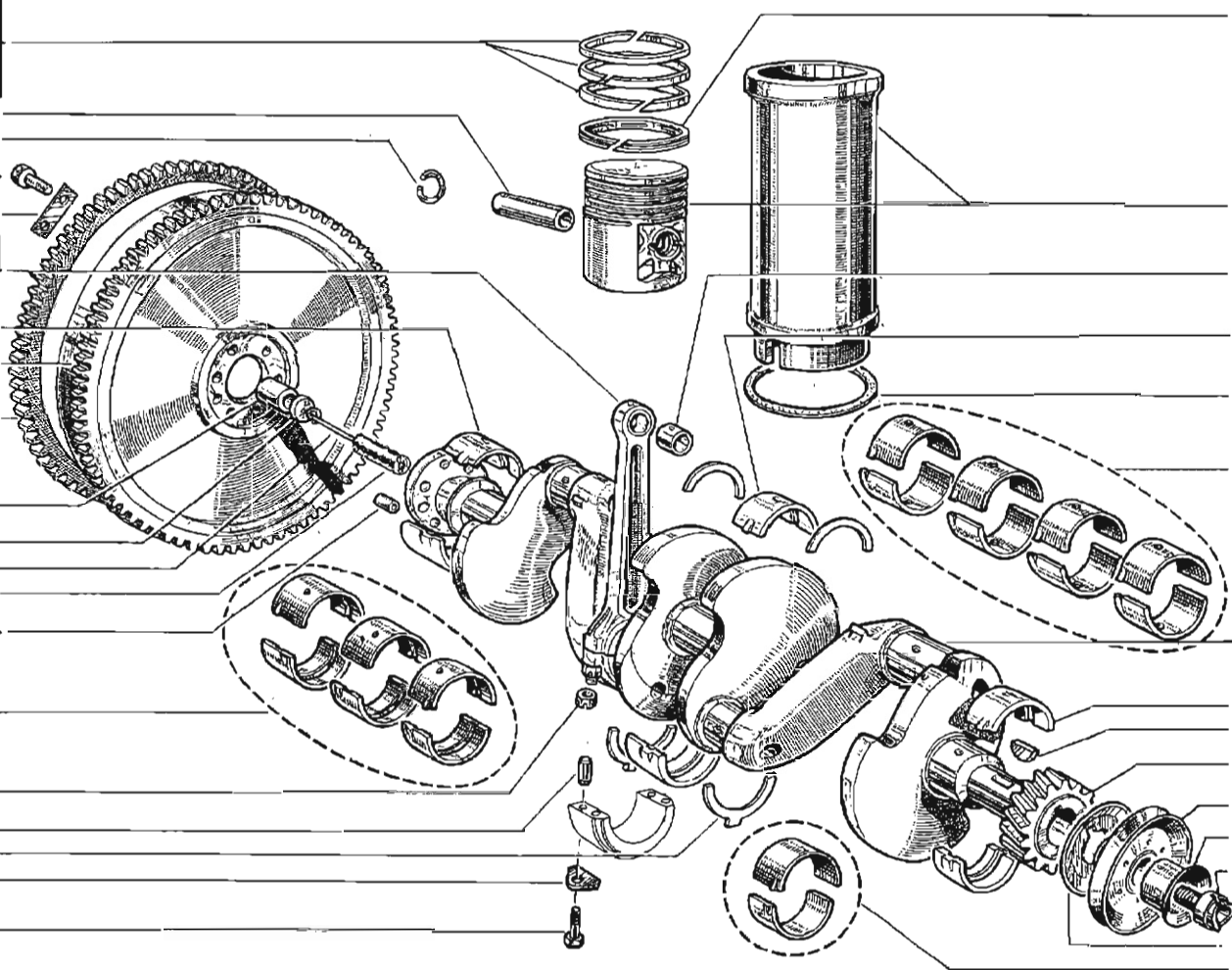

- { 6 040 006 (s)
- 8 536 911 †
- 8 538 975 } (m)
- (9)
- { 5 539 294 † (e)
- 5 545 007 †
- 5 552 664 } (f)
- (5)
- (10)
- (3)
- 9 809 431 † (t)
- 9 810 205 † (a)
- 9 811 928 † (u)
- 9 811 681 † (g)
- 9 803 560 (v)
- (6)
- 7 035 006
- { 5 521 535 †
- 5 548 144
- 8 240 442 (w)
- 8 242 061 (y)
- 6 035 440
- 6 036 111
- 6 027 683 (b)
- (2)

(1)	6033998 † } DE=14 6057133
(j)	{ 7109141 DE=14,2 7109142 DE=14,5

(2)	(g) 9811973 † } (h) 9803563 † } 9806083 DI=38
(3)	(g) 9811975 † } (h) 9803566 † } 9806082 DI=37,75
	(g) 9811976 † } (h) 9803565 † } 9806081 DI=37,5
	(g) 9811977 † } (h) 9804564 † } 9806080 DI=37

(4)	(5)	(6)	(7)
9809429 †	9809428 †	9809427 †	9806094 DI=40
9809506 †	9809509 †	9809512 †	9806091 DI=39,75
9809507 †	9809510 †	9809513 †	9806092 DI=39,5
9809508 †	9809511 †	9809514 †	9806093 DI=39

(8)	(n) 9809426 } E=2 (p) 6033942
	(n) 9811974 } E=2,05 (p) 6055545
	(n) 9809515 } E=2,10 (p) 7109039
	(n) 9809516 } E=2,15 (p) 7109040

(9)	{ 9810519 † 9803176 † 9803454
(r)	{ 9803105 † 9803177 † 9803453

(10)	(q) 7058187 } E=0,95 (r) 6051845
	(q) 7058703 } E=0,90 (r) 6051846
	(q) 7109161 } E=1,05 (r) 7109308
	(r) 6066250 E=1,00

	n°...	n°...	!!!
(a)	1 MOT	533969	
(b)	1 MOT	723581	
(c)	1 MOT	802500	
(d)	802501 MOT	...	
(e)	1 MOT	616598	
(f)	616599 MOT	...	
(g)	616599 MOT	771800	
(h)	771801 MOT	...	
(j)	1 MOT	337568	
(k)	1 MOT	617040	
(s)	1 MOT	537793	
(m)	637794 MOT	...	
(n)	1 MOT	747728	
(p)	747729 MOT	...	
(q)	1 MOT	584308	
(r)	584309 MOT	...	
(t)	1 MOT	533969	53
(u)	533970 MOT	616598	53
(v)	771801 MOT	...	228
(w)	1 MOT	733581	84
(y)	733582 MOT	...	84
(z)	1 MOT	616598	57
(aa)	616599 MOT	762990	57
(ab)	762991 MOT	...	

(11)	9803587-21 358 g 9803587-30 378 g 9803587-40 348 g 9803587-51 328 g 9803587-70 368 g 9803587-90 338 g
------	--

84	00000	06-00
----	-------	-------

53	06-00
57	06-00
228	06-00



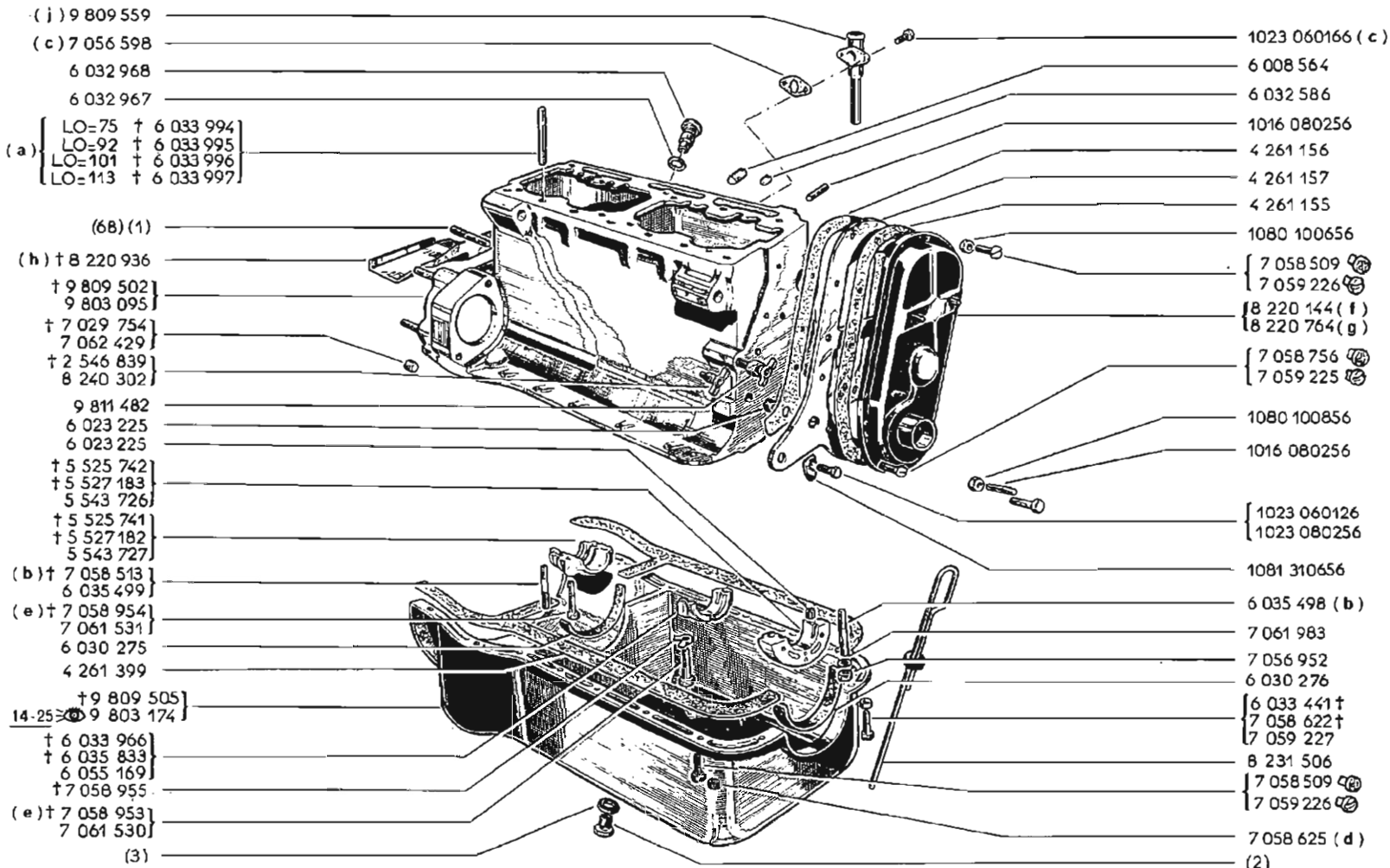

- (j) 9 809 559
- (c) 7 056 598
- 6 032 968
- 6 032 967
- (a) {
 - LO=75 † 6 033 994
 - LO=92 † 6 033 995
 - LO=101 † 6 033 996
 - LO=113 † 6 033 997
- (68) (1)
- (h) † 8 220 936
- † 9 809 502
- 9 803 095
- † 7 029 754
- 7 062 429
- † 2 546 839
- 8 240 302
- 9 811 482
- 6 023 225
- 6 023 225
- † 5 525 742
- † 5 527 183
- 5 543 726
- † 5 525 741
- † 5 527 182
- 5 543 727
- (b) † 7 058 513
- 6 035 499
- (e) † 7 058 954
- 7 061 531
- 6 030 275
- 4 261 399
- † 9 809 505
- 14-25 † 9 803 174
- † 6 033 966
- † 6 035 833
- 6 055 169
- † 7 058 955
- (e) † 7 058 953
- 7 061 530
- (3)

- 1023 060166 (c)
- 6 008 564
- 6 032 586
- 1016 080256
- 4 261 156
- 4 261 157
- 4 261 155
- 1080 100656
- { 7 058 509 (a)
- { 7 059 226 (b)
- { 8 220 144 (f)
- { 8 220 764 (g)
- { 7 058 756 (a)
- { 7 059 225 (b)
- 1080 100856
- 1016 080256
- { 1023 060126
- { 1023 080256
- 1081 310656
- 6 035 498 (b)
- 7 061 983
- 7 056 952
- 6 030 276
- { 6 033 441 †
- { 7 058 622 †
- { 7 059 227
- 8 231 506
- { 7 058 509 (a)
- { 7 059 226 (b)
- 7 058 625 (d)
- (2)

- (a) MOT n° 1 ⇨ MOT n° 20500
- (b) MOT n° 1 ⇨ MOT n° 20299
- (c) MOT n° 1 ⇨ MOT n° 836368
- (d) { MOT n° 565 ⇨ MOT n° 600
- { MOT n° 619 ⇨ MOT n° ...
- (e) MOT n° 20300 ⇨ MOT n° ...
- (f) MOT n° 1 ⇨ MOT n° 35529
- (g) MOT n° 35530 ⇨ MOT n° ...
- (h) MOT n° 66024 ⇨ MOT n° ...
- (j) MOT n° 1 ⇨ MOT n° 756376

	(1)	(2)	(3)
7058635 †	} LO=50	7029707 DE=14	17138 DI=18
7058668		7029708 DE=18	7033278 DI=14
7058636 †	} LO=43		
7058445 †			
6042720			

- (k) 9 809 559
- 8 241 100
- (d) 7 056 598
- (c) 6 062 832
- 6 032 968
- 6 032 967
- 6 008 564
- 6 032 586
- (1)
- † 8 220 936
- 8 238 633
- (FERLEC) { † 8 224 185
- 8 238 632
- (u) † 9 811 761
- (q) † 9 809 502
- (r) 9 803 095
- (FERLEC) { (s) † 9 811 840
- (t) 9 803 096
- † 7 029 754
- 7 062 429
- (g) 8 240 302
- (h) 8 241 009
- 9 811 482
- 6 023 225
- 6 023 225
- (FERLEC) 6 052 435
- † 5 525 741
- † 5 527 182
- 5 543 727
- 7 061 531
- 6 030 275
- 4 261 399
- (FERLEC) (e) { 14-25
- 9 809 505
- † 9 811 628
- 9 803 078
- (f) 9 803 067
- (FERLEC) 6 052 438
- † 6 033 966
- † 6 035 833
- 6 055 169
- † 7 058 955
- 7 061 530
- 6 064 334

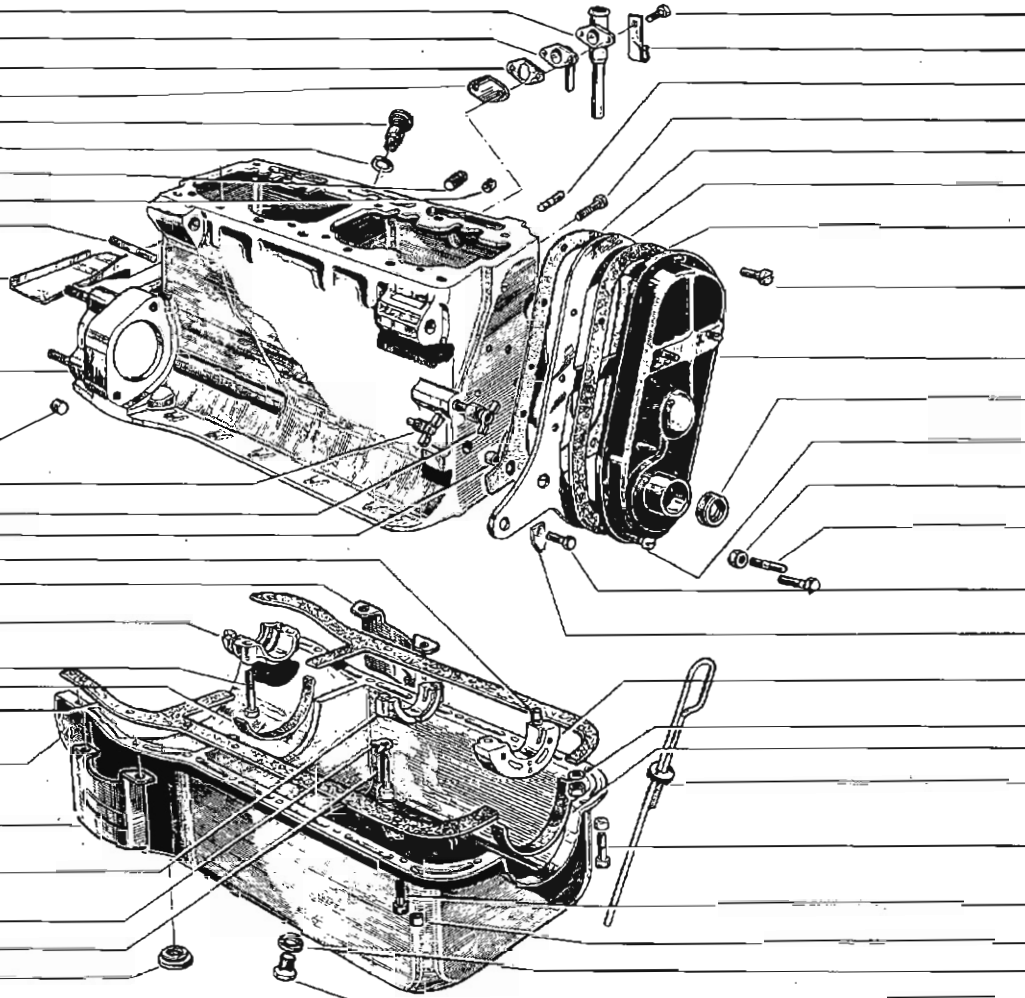

- 1023 060166
- { 4 250 612 (b)
- { 6 048 314 (a)
- 1016 080256
- 7 029 703 (b)
- 4 261 156
- 4 261 157
- 4 261 155
- { 7 058 509 (a)
- { 7 059 226 (a)
- { 8 220 764 (m)
- { 8 224 865 (n)
- { 8 225 784 (p)
- 8 539 995 (j)
- { 7 058 756 (a)
- { 7 059 225 (a)
- 1080 100856
- 1016 080256
- { 1023 060126
- { 1023 080256
- { 1023 080506
- 1081 310656
- { 5 525 742 †
- { 5 527 183 †
- { 5 543 726
- 7 061 983
- 6 030 276
- { 8 231 506 (e)
- { 8 236 073 (f)
- { 6 033 441 †
- { 7 058 622 †
- { 7 059 227
- { 7 058 509 (a)
- { 7 059 226 (a)
- 7 058 625
- (3)
- (2)

(1)	(2)	(3)
6042720 LO = 43	7029707 DE = 14	17138 OI = 18
6068523 LO = 28	7029709 DE = 18	7033278 OI = 14
7058668 LO = 50		
7062706 LO = 40		

XXXX 00000	
25	08-00
26	08-00
84	08-00

	XXXX 00000	!!!
n°...	↔	n°...
(a)	224887 MOT	225000
	225569 MOT	836368
(b)	836369 MOT	...
(c)	756377 MOT	836368
(d)	1 MOT	836368
(e)	1 MOT	586593
(f)	586594 MOT	...
(g)	1 MOT	202920
(h)	202921 MOT	...
(j)	732582 MOT	...
(k)	1 MOT	756378
(m)	1 MOT	723581
(n)	723582 MOT	869015 84
(p)	869016 MOT	...
(q)	450604 VEH	...
	1 MOT	584308 25 26
(r)	584309 MOT	...
		173 238
(s)	1 MOT	584308
(t)	584309 MOT	...
		238
(u)	1 VEH	450603 26 25 173

!!!	
173	9803106 - 1 - 9803179 - 1 -
238	08-00



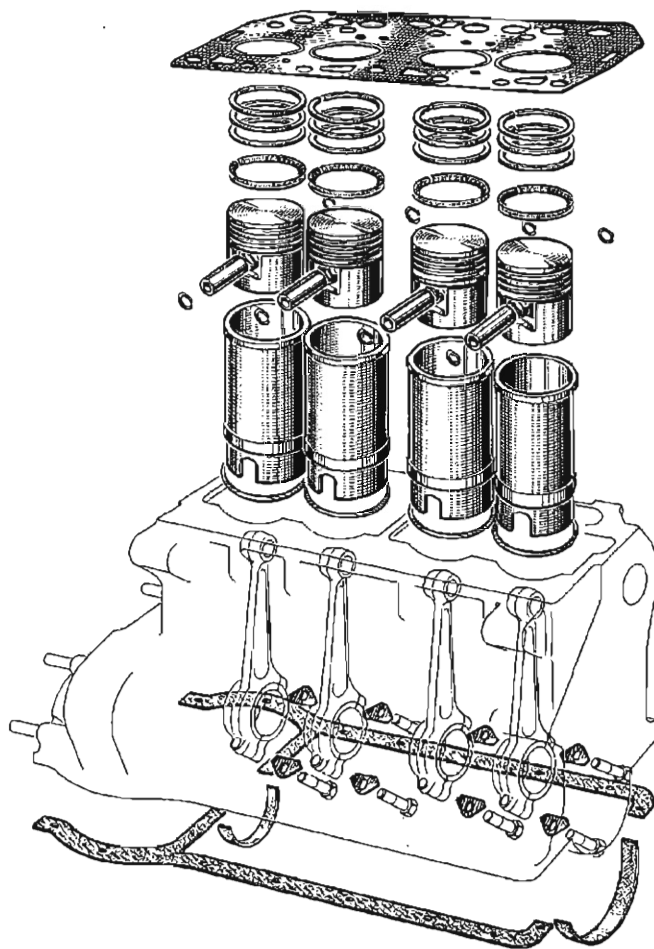

- | | | |
|-----------------|---|-----|
| 9 808 473 † (a) | } | (b) |
| 9 810 987 † | | |
| 9 803 178 † | } | (c) |
| 9 803 986 | | |
| 9 803 106 † | } | (c) |
| 9 803 179 † | | |
| 9 803 987 | | |

- (a) MOT n° 1 ⇨ MOT n° 637793
 (b) MOT n° 1 ⇨ MOT n° 584308
 (c) MOT n° 584309 ⇨ MOT n° ...

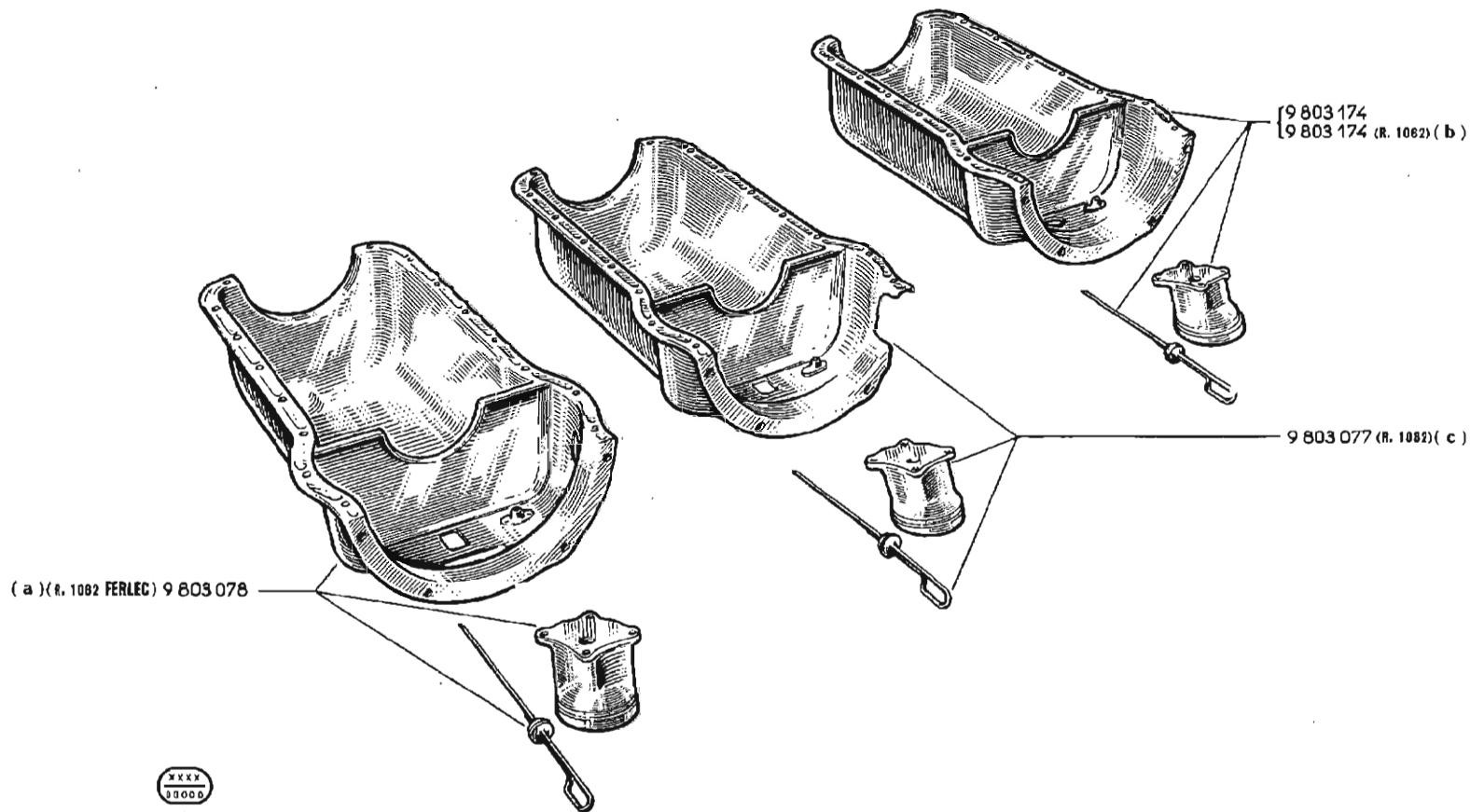

XXXX
0000

25	08-00
26	08-00

XXXX
0000

	n°...	n°...			
(a)	1 MOT	586593			
(b)	1 VEH	450603	26	25	
(c)	450604 VEH	586593			



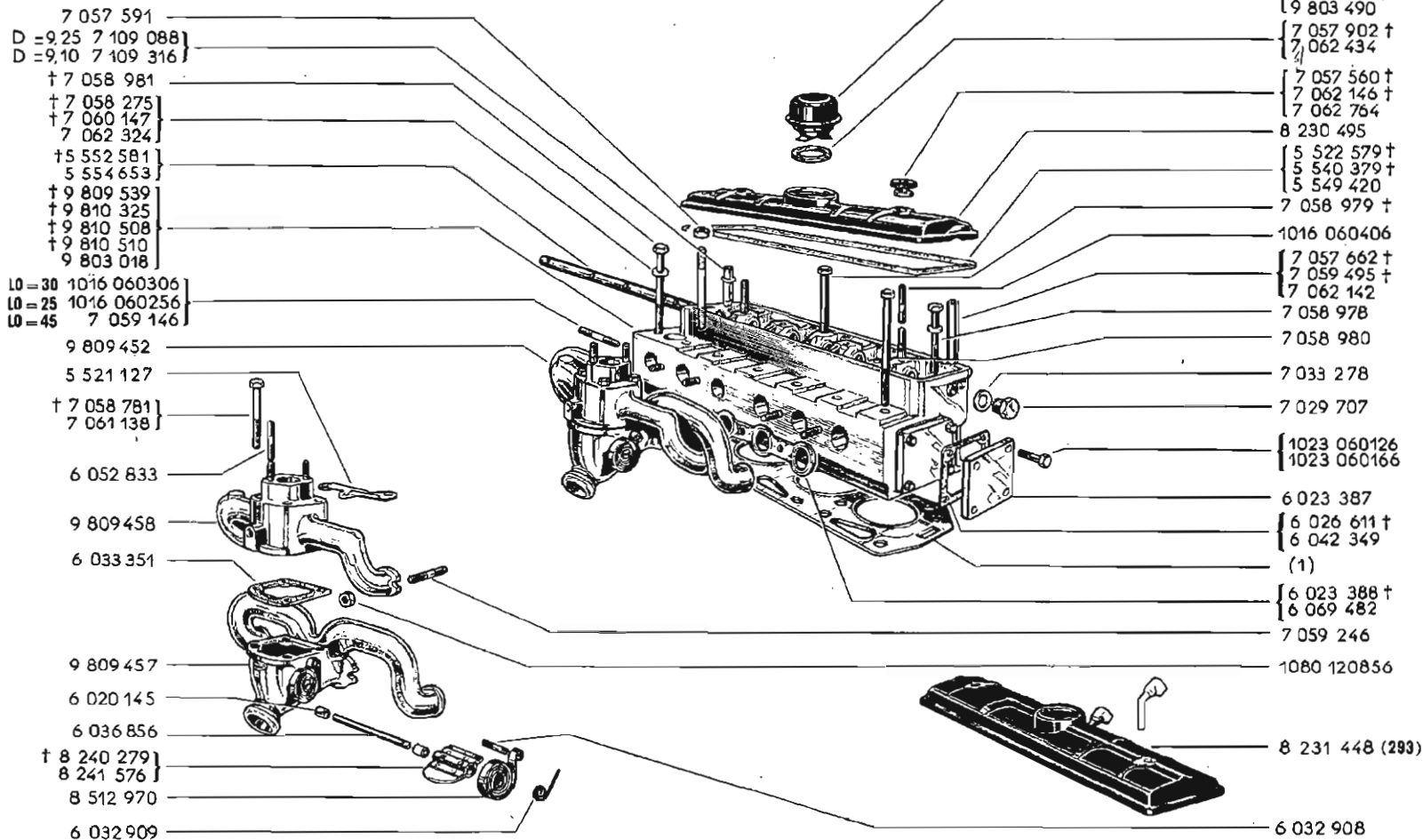

293 06-00

(1)		
5528894 †	DI = 56	E = 0,6
5524842	DI = 56	E = 1,2
8516245 †	DI = 56	E = 1,2
5539842	DI = 56	E = 1,2
8525381	DI = 56,8	E = 1,2

(293) 8 519 129
 † 8 512 484
 † 8 241 241
 † 9 803 490
 US 9 806 168

† 7 057 902
 7 062 434

(293) 8 231 448

(293) 8 232 730

8 230 495

(2)

† 7 058 275
 † 7 060 147
 7 062 324

5 522 581

LO = 120 7 058 981
 LO = 115 7 062 542

LO = 30 1016 060306
 LO = 25 1016 060256
 LO = 45 7 059 146

(a) † 9 809 539
 † 9 810 325
 † 9 810 508
 † 9 810 510

(b) 9 803 018
 (c) 9 803 711

US (a) † 9 811 770
 (d) 9 803 038
 (e) 9 803 712
 (f) 9 803 711

(1)

7 058 980

8 516 673

{ 7 057 560 †
 7 062 146 †
 7 062 764

{ 7 058 979 †
 7 062 541

{ 5 522 579 † (q)
 5 540 379 (r)
 5 549 420 (s)

1016 060406

{ 7 057 662 †
 7 059 495 †
 7 062 142

7 058 978

6 046 172 (p)

7 029 707 (n)

7 033 278

1023 060166

6 023 387

{ 6 026 611 †
 6 042 349

293



(1)

5528894 †	D1=56	E=0,6
8516245 †	D1=56	E=1,2
5524842 †	D1=56	E=1,2
5539842	D1=56	E=1,2
8525381	D1=56,8	E=1,2

(2)

(g) 7109088	DE = 9,25
(h) { 7109310 † 7109326 † }	DE = 10,25
(h) { 7109319 † 7109327 }	DE = 10,10
(j) 7109316	DE = 9,10

	n°...	⇒	n°...	⊗	⊗	!!!
(a)						70
(b)	1 MOT		791922			
(c)	791923 MOT		...			
(d)	1 MOT		791922			70
(e)	791923 MOT		872575			
(f)	872576 MOT		...			
(g)	1 MOT		556444			
	556901 MOT		556925			
(h)	556445 MOT		556900			
	556926 MOT		...			
(j)	1 MOT		556925			
(n)	1 MOT		211250			
(p)	211251 MOT		...			
(q)	1 MOT		474083			
(r)	474084 MOT		765348			
(s)	765349 MOT		...			



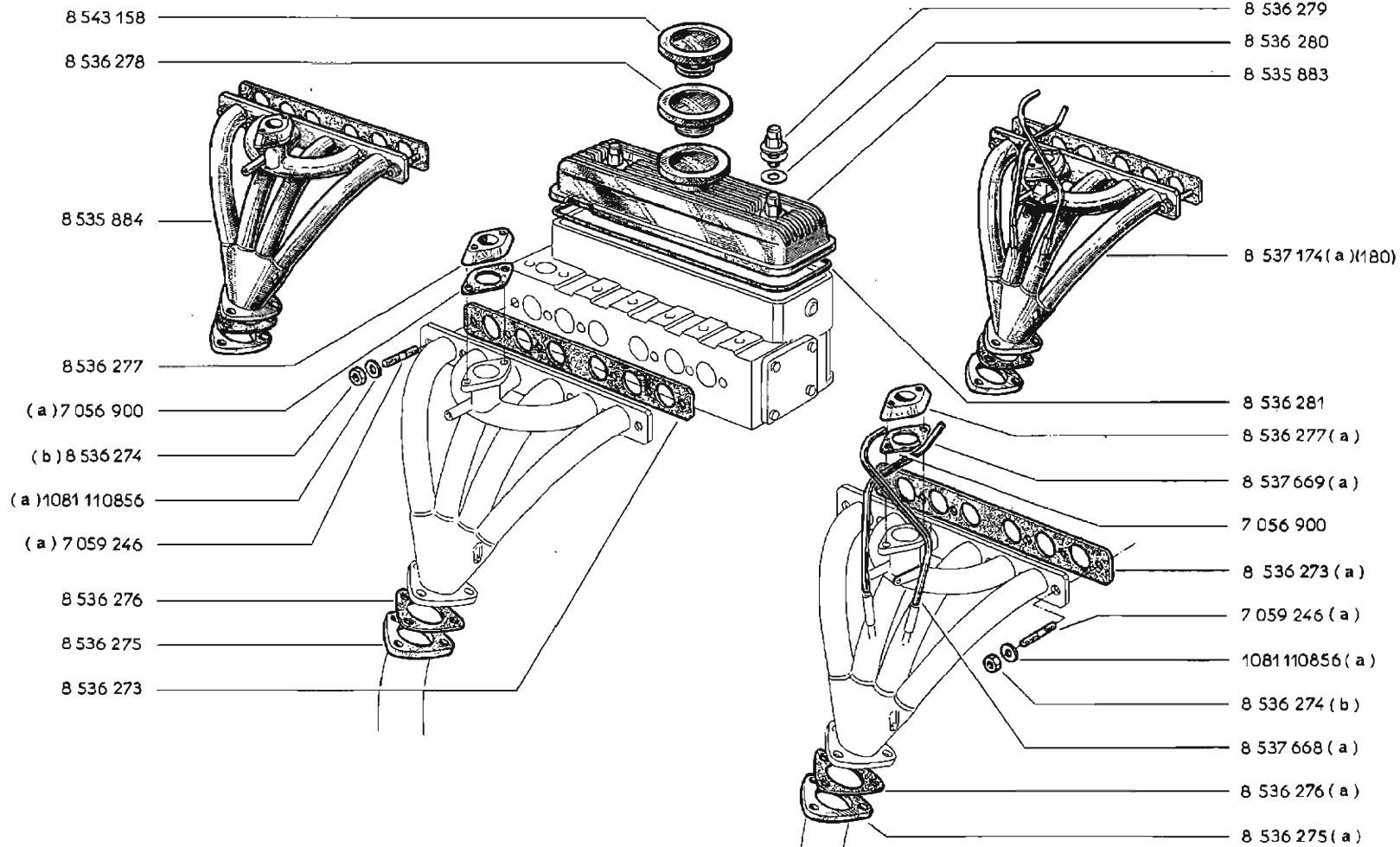

(a) MOT n° 1 ⇨ MOT n° 872575
 (b) MOT n° 872576 ⇨ MOT n° ...

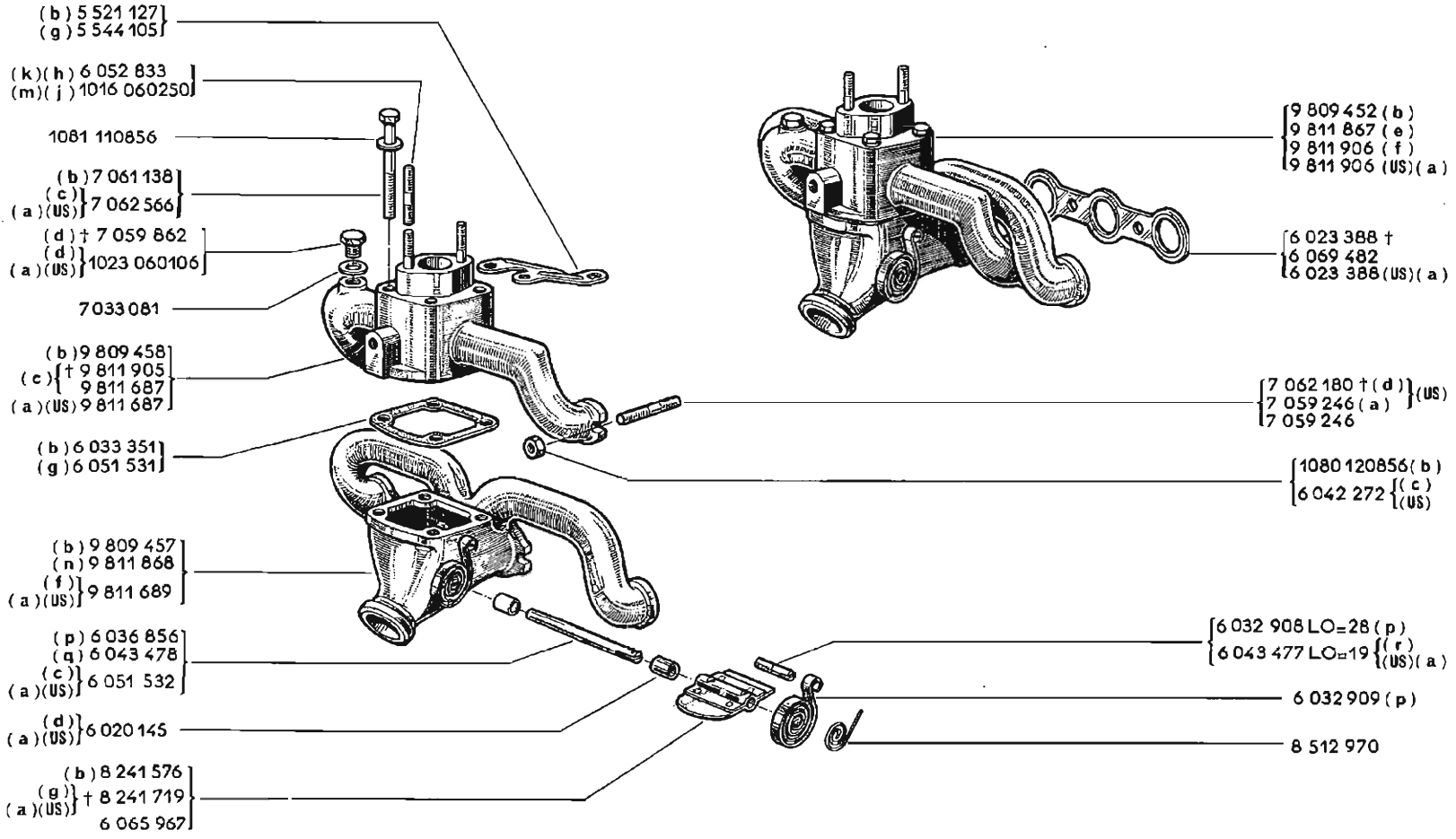

xxx
oooo

32	08-00
----	-------

	xxx oooo	n°...	n°...	!!!
(a)	872576 MOT	...		
(b)	1 MOT	521144		
(c)	521145 MOT	872575		
(d)	1 MOT	872575		
(e)	521145 MOT	532892	32	
(f)	532893 MOT	872575	32	
(g)	521145 MOT	...		
(h)	1 MOT	401972		
(j)	401973 MOT	521144		
(k)	521145 MOT	820600		
(m)	820601 MOT	...		
(n)	521145 MOT	532892		
(p)	1 MOT	103838		
(q)	103839 MOT	521144		
(r)	103839 MOT	872575		



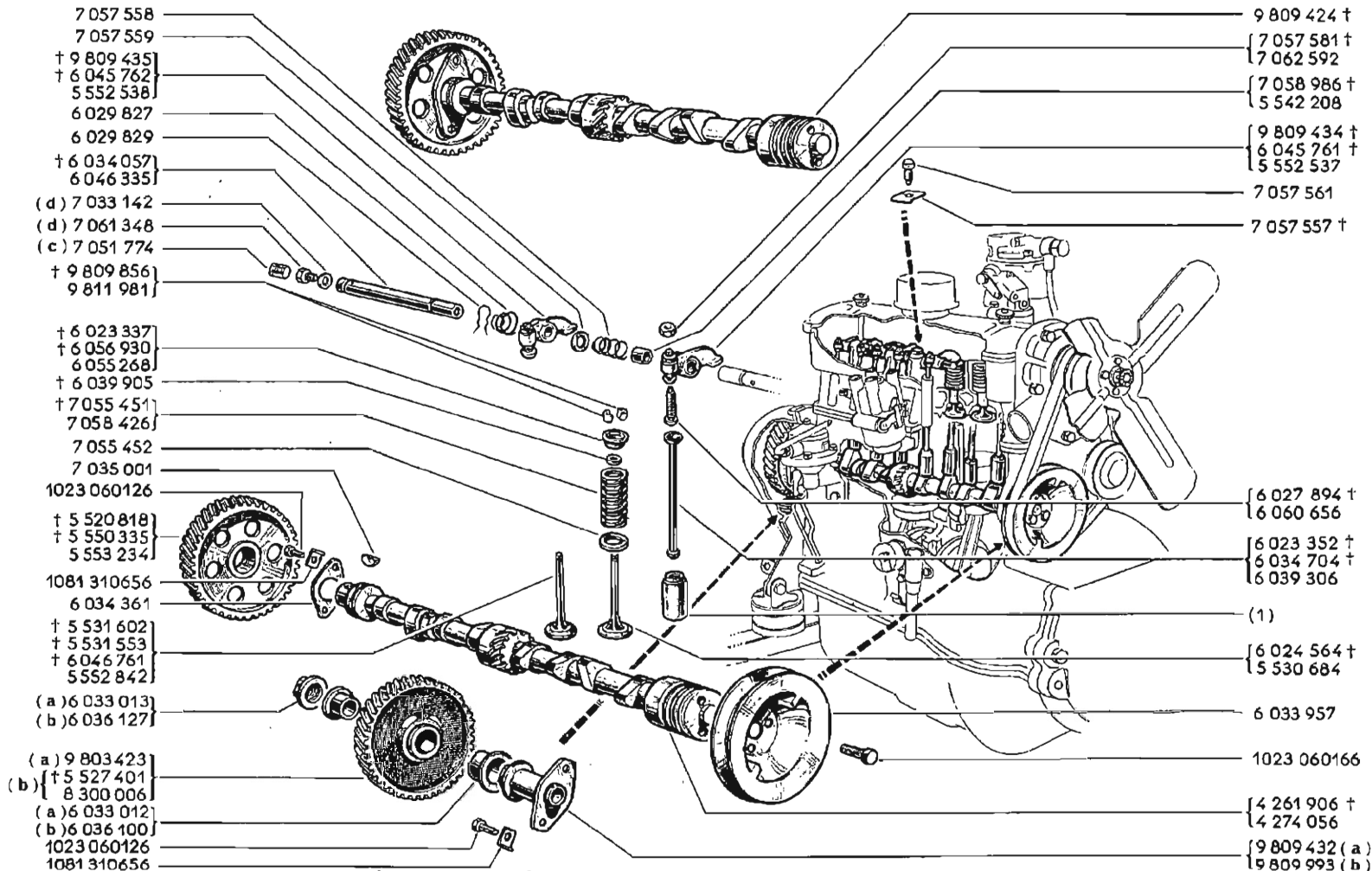

- 7 057 558
- 7 057 559
- † 9 809 435
- † 6 045 762
- 5 552 538
- 6 029 827
- 6 029 829
- † 6 034 057
- 6 046 335
- (d) 7 033 142
- (d) 7 061 348
- (c) 7 051 774
- † 9 809 856
- 9 811 981
- † 6 023 337
- † 6 056 930
- 6 055 268
- † 6 039 905
- † 7 055 451
- 7 058 426
- 7 055 452
- 7 035 001
- 1023 060126
- † 5 520 818
- † 5 550 335
- 5 553 234
- 1081 310656
- 6 034 361
- † 5 531 602
- † 5 531 553
- † 6 046 761
- 5 552 842
- (a) 6 033 013
- (b) 6 036 127
- (a) 9 803 423
- (b) † 5 527 401
- 8 300 006
- (a) 6 033 012
- (b) 6 036 100
- 1023 060126
- 1081 310656

- 9 809 424 †
- { 7 057 581 †
- { 7 062 592
- { 7 058 986 †
- { 5 542 208
- { 9 809 434 †
- { 6 045 761 †
- { 5 552 537
- 7 057 561
- 7 057 557 †
- { 6 027 894 †
- { 6 060 656
- { 6 023 352 †
- { 6 034 704 †
- { 6 039 306
- (1)
- { 6 024 564 †
- { 5 530 684
- 6 033 957
- 1023 060166
- { 4 261 906 †
- { 4 274 056
- { 9 809 432 (a)
- { 9 809 993 (b)

(1)	
8230131	DE = 19
7109043	DE = 19, 2
7109044	DE = 19, 5

- (a) MOT n° 1 ⇨ MOT n° 35529
- (b) MOT n° 35530 ⇨ MOT n° ...
- (c) MOT n° 1 ⇨ MOT n° 300
- (d) MOT n° 301 ⇨ MOT n° ...

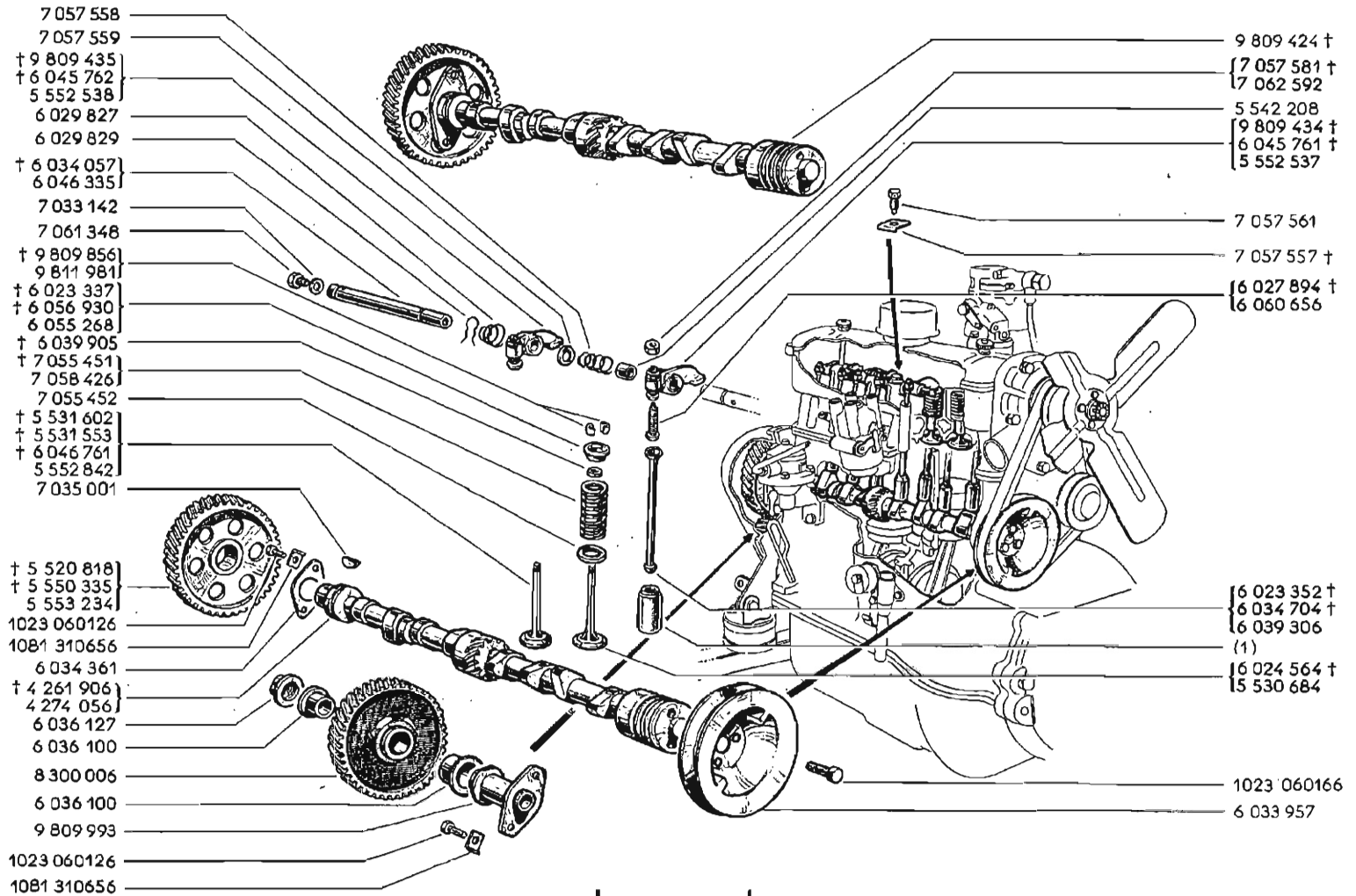

(1)

8230131	DE = 19
7109043	DE = 19,2
7109044	DE = 19,5

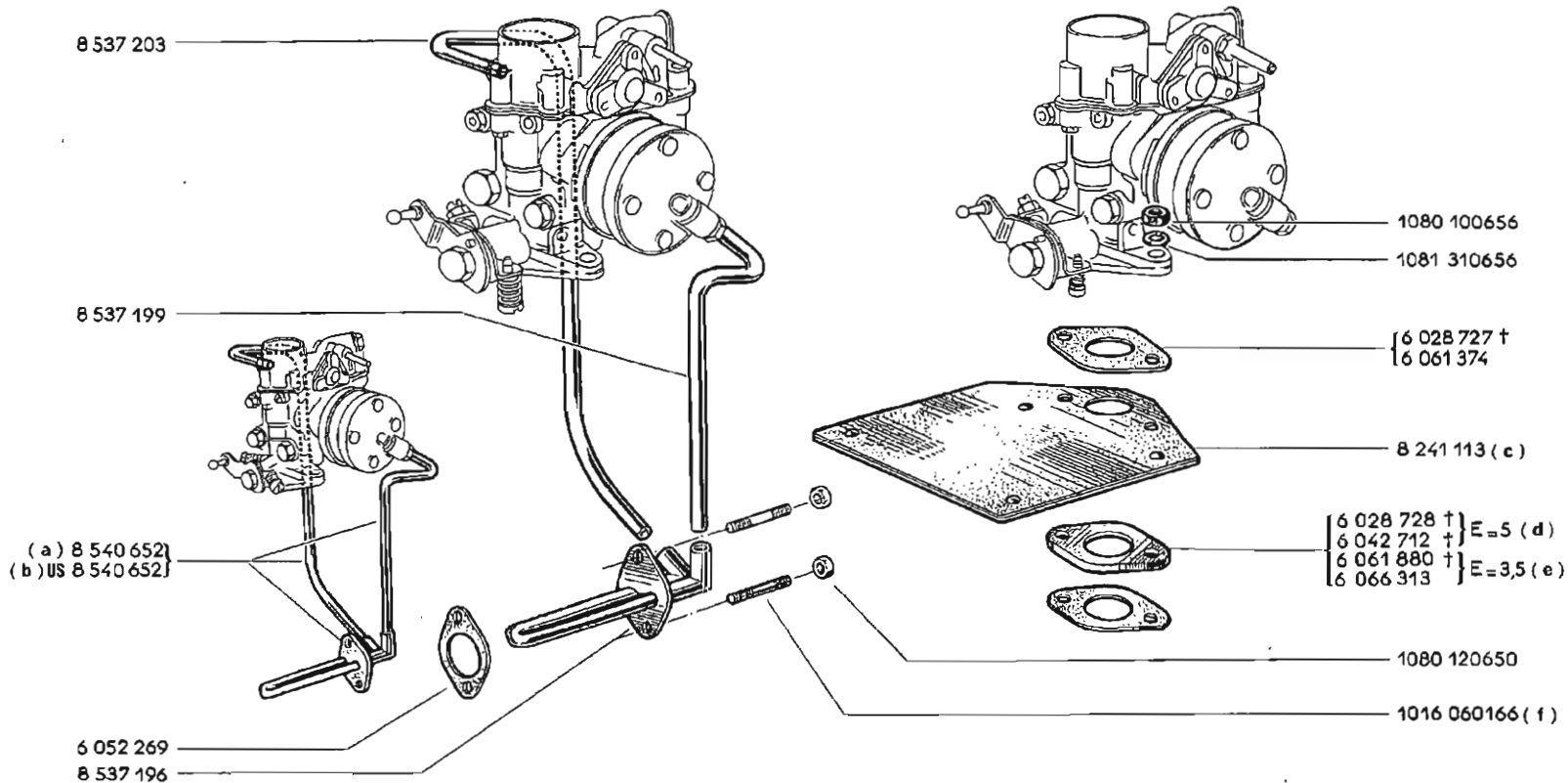



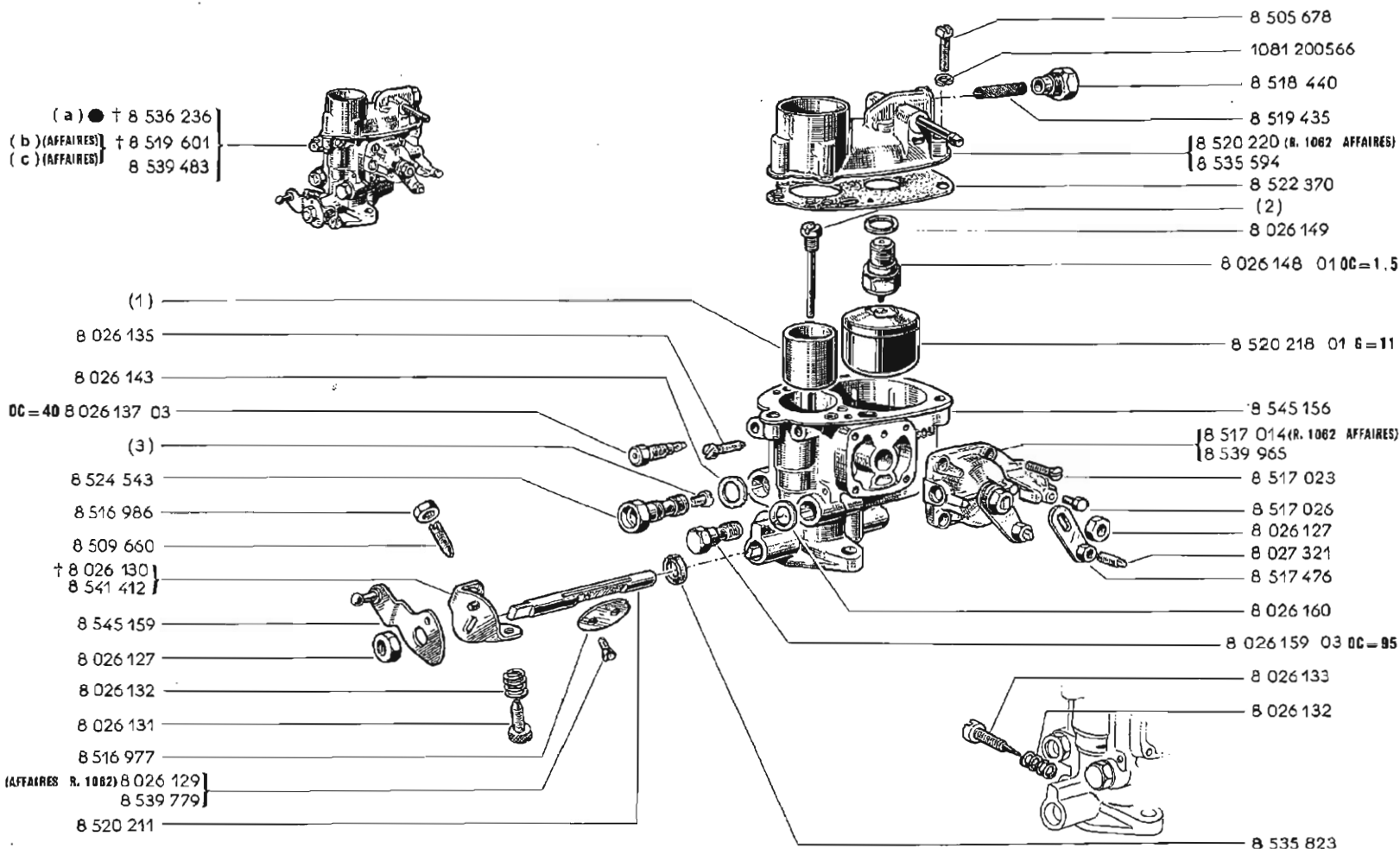

- (a) MOT n° 1 □ MOT n° 872575
- (b) MOT n° 872576 □ MOT n° ...
- (c) { VEH n° 302855 □ VEH n° 302900
VEH n° 304549 □ VEH n° ...
- (d) MOT n° 1 □ MOT n° 820600
- (e) MOT n° 820601 □ MOT n° ...
- (f) { VEH n° 531953 □ VEH n° 532000
VEH n° 532651 □ VEH n° 532816
VEH n° 532893 □ VEH n° ...





(1)	(2)	(3)
8520216 DI=14,5	8524402-07 DC=175	8026144-09 DC=75
8520216-01 DI=18	8524402-15 DC=190	● 8026144-15 DC=95
	● 8524402-25 DC=160	8026144-17 DC=100

XXXX
00000

32	 08-00
36	 08-00
45	 08-00
52	 08-00
57	 08-00

XXXX
00000

	n°...	⇒	n°...			
(a)	496662 VEH		532892	57	32 38	
(b)	230931 MOT		...	45		77
(c)	230931 MOT	VEH	239716	45		77
	240001 VEH		240732	52		77

!!!

77		7604450 -2- 7604472 -2-
----	---	----------------------------



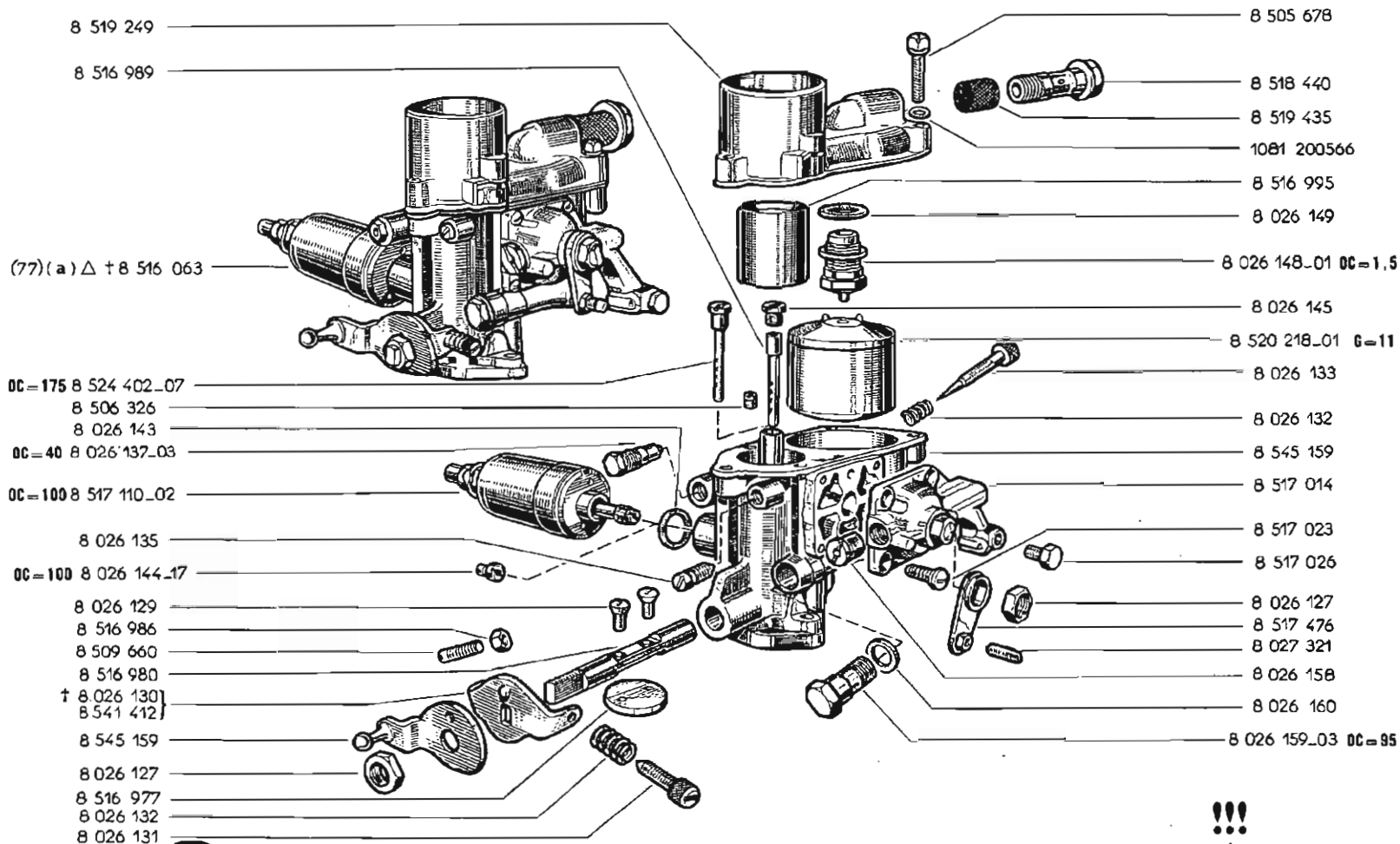

43 08-00

(a) n°... n°...

77 7604450 -2-
7604472 -2-

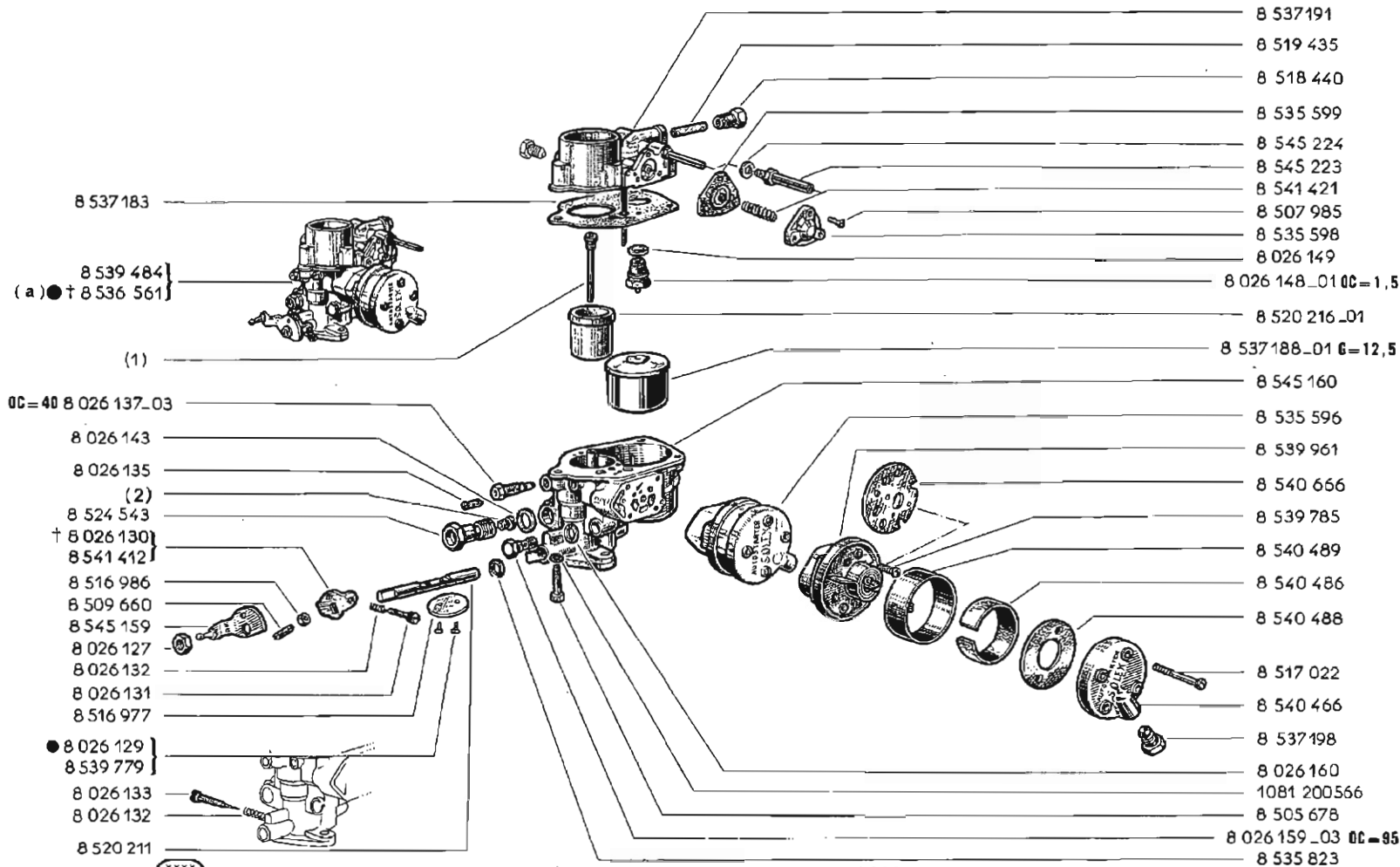

32 XXXX
00000 00-00

(a) n°... XXXX
00000 n°... 32 !!!

(1)		(2)	
8524402-07	OC = 175	8026144-17	OC = 100
8524402-25 ●	OC = 160	8026144-15 ●	OC = 95

22 ICBT Δ

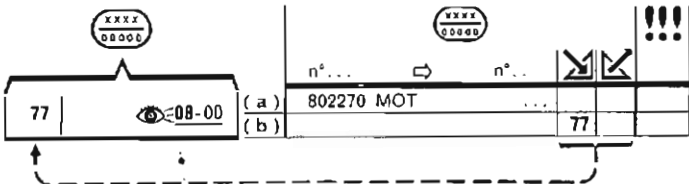
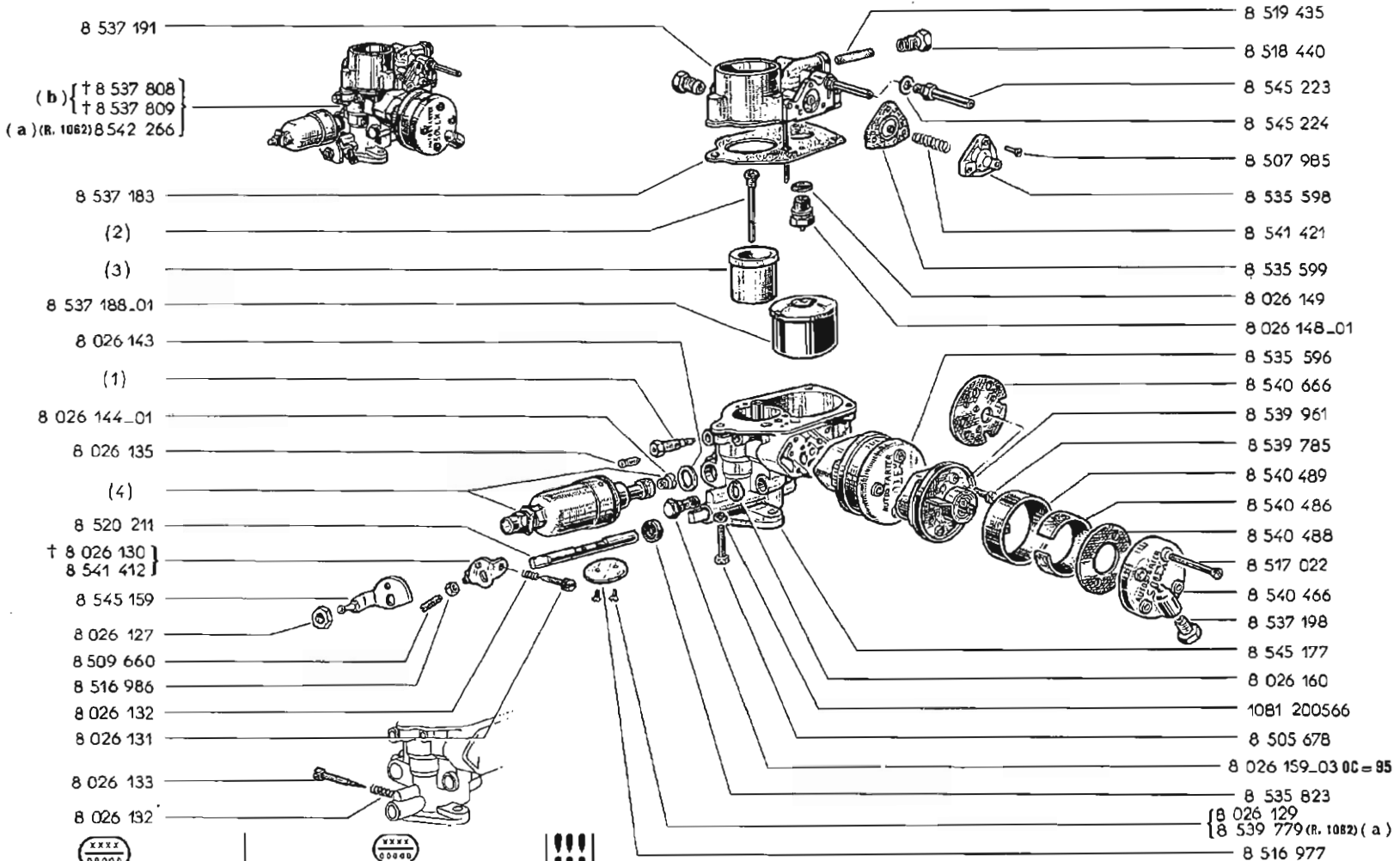

(1)	(2)	(3)	(4)
(a) 8026137-01 OC=35	(a) 8524402-07 OC=175	8520216-01 DI=18	8517110-02 OC=100
8026137-03 OC=40	8524402-03 OC=160	(a) 8520216-05 DI=16	(a) 8517110-07 OC=80
	8524402 OC=165		

△●(US)
 (c)(R.1062) † 5 526 018
 (d)(R.2071)
 (e)(R.1062) 5 548 077

8 526 320
 ● 8 521 987

5 534 265

XXXX
00000

52

08-00

	n°...	n°...	⚡	!!!
(a)	1 MOT	300		
(b)	301 MOT	...		
(c)	1 VEH	239716	52	
	240000 VEH	240732		
(d)	1 VEH	4240		
(e)	787266 VEH	...		

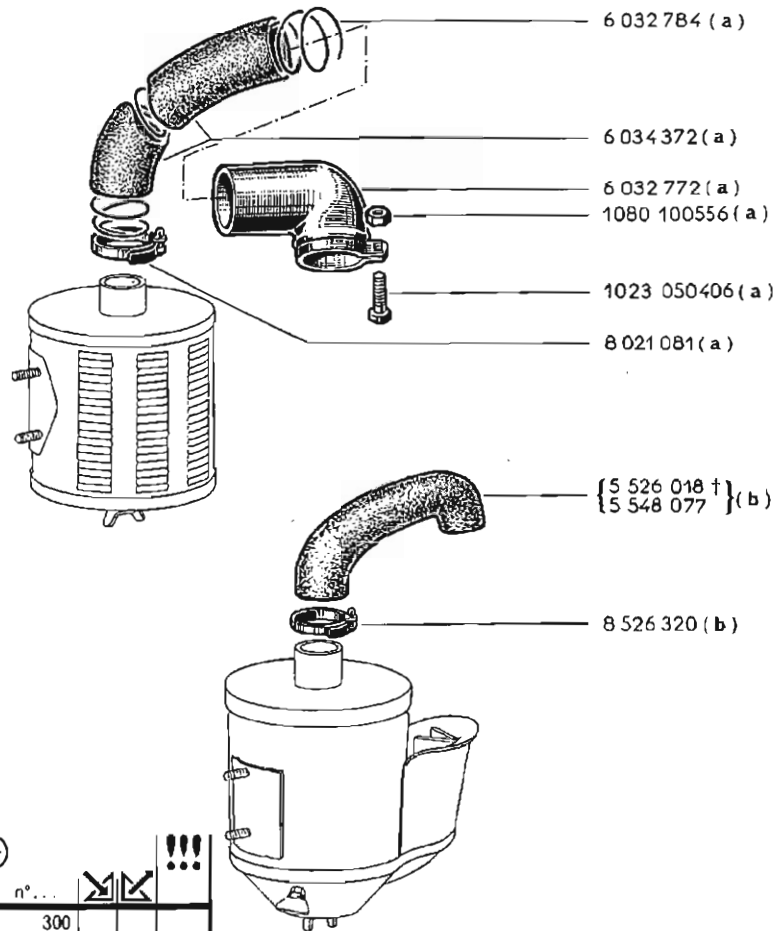
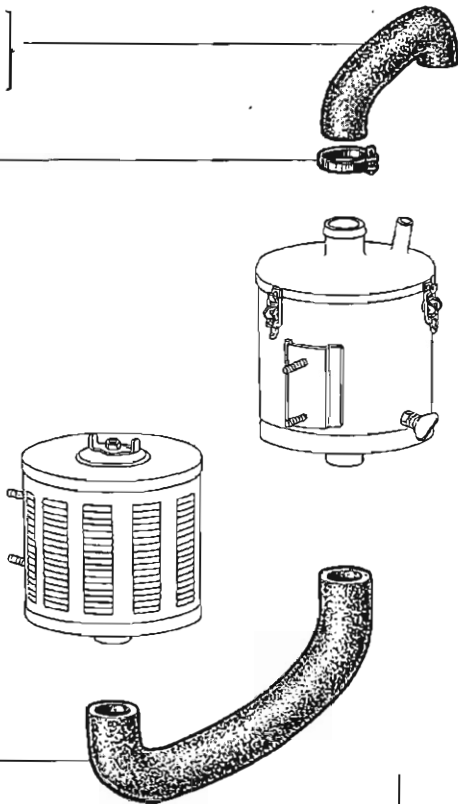

6 032 784 (a)

6 034 372 (a)

6 032 772 (a)

1080 100556 (a)

1023 050406 (a)

8 021 081 (a)

{ 5 526 018 †
5 548 077 } (b)

8 526 320 (b)

(R. 1082) (a) 8 535 942

(R. 1082) 8 537 001

(R. 1082) 8 538 775

(R. 1082) { +8 537 000
8 541 183 }

(R. 1082) 8 536 999

(R. 1082) 8 536 998

(R. 1082) 8 520 189

8 538 767 (R. 1082) (R. 2071)

8 538 776 (R. 1082) (R. 2071)

8 538 775 (R. 1082) (R. 2071)

8 520 189 (R. 1082) (R. 2071)

8 510 521 (R. 1082) (R. 2071)

8 510 523 (R. 1082) (R. 2071)

(a) VEH n° 496662 ⇨ VEH n° ...

15.59

A P.R. 685

TECALEMIT ● (R. 1062) (R. 2071)

15.59

A P.R. 685

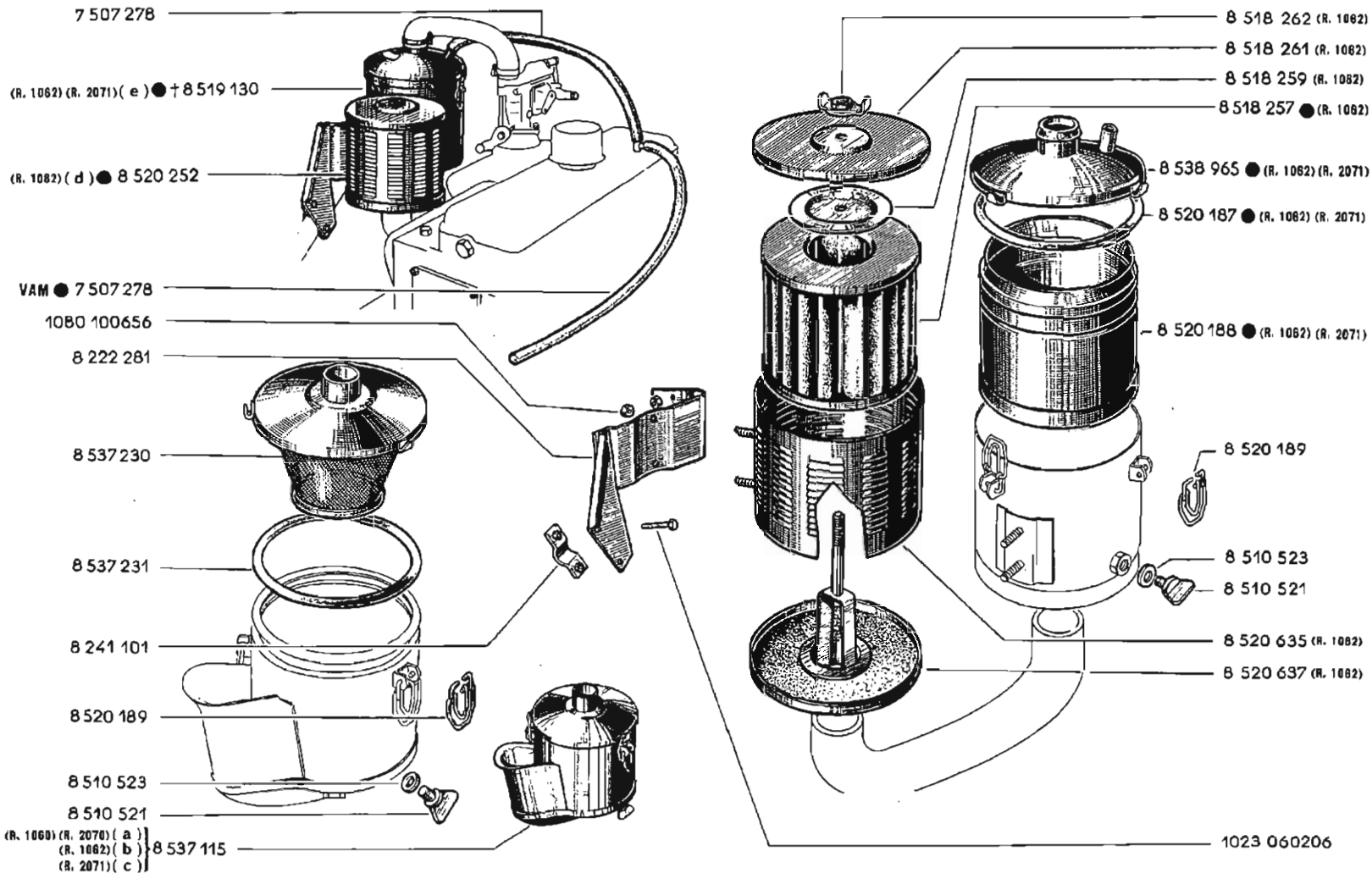

XXXX
00000

36	08-00
51	08-00
52	08-00
53	08-00
57	08-00

XXXX
00000

	n°...	n°...	!!!	!!!	!!!
(a)			51	53	71
(b)	1 VEH	239716	52		
(c)	1 VEH	4240			
(d)			57	36	
(e)	1 VEH	656592			

!!!

71	06-00
----	-------



XXXX
00000

50	08-00
51	08-00
52	08-00
53	08-00

XXXX
00000

!!!

	n°...	⇒	n°...	⊗	⊗	
(a)						71
(b)				50 53	52	
(c)	1 VEH		239716	51 52	53	
(d)	1 VEH		4240			

!!!

71	06-00
----	-------



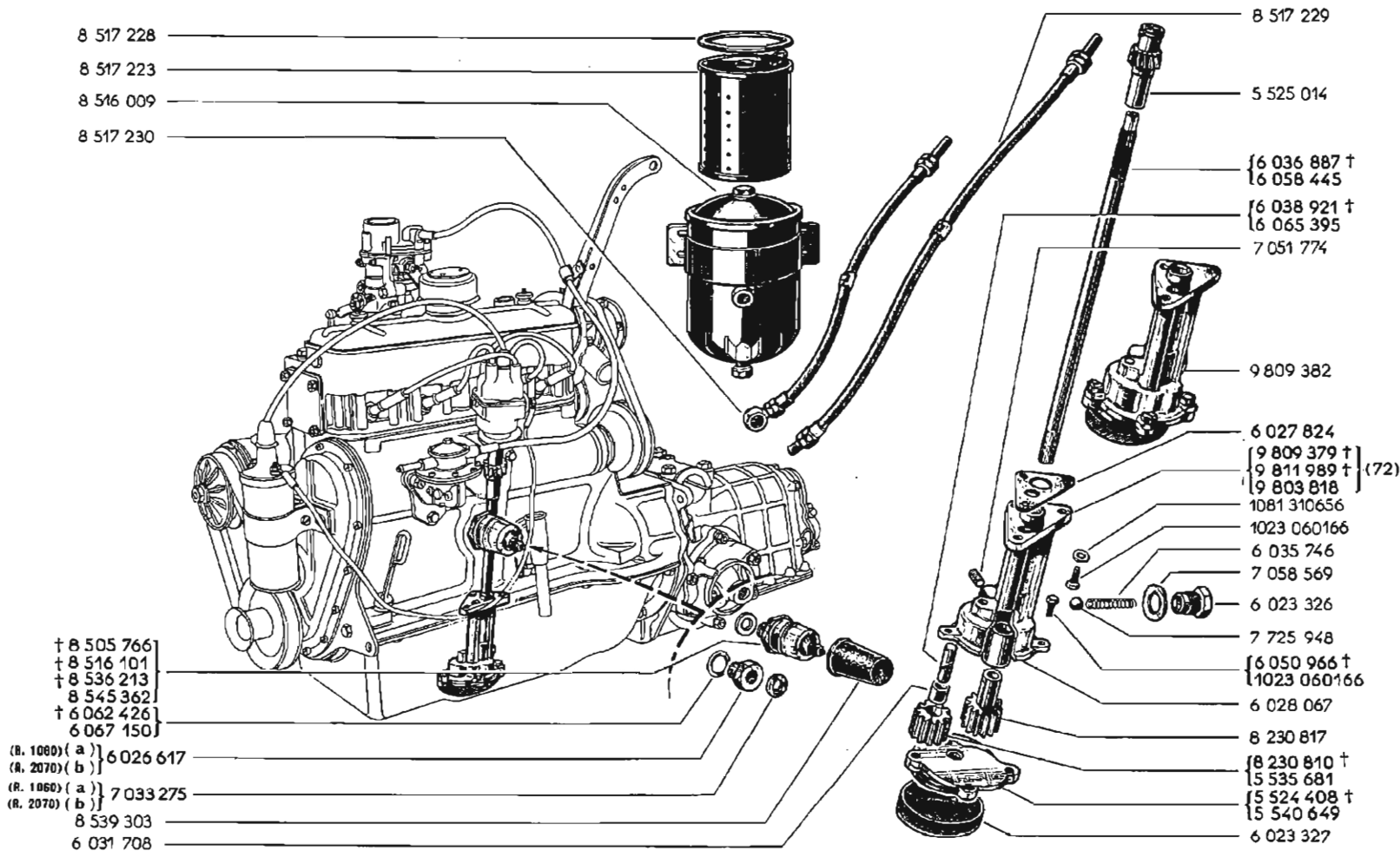

(a) VEH n° 1 ⇨ VEH n° 101800
 (b) VEH n° 1 ⇨ VEH n° 9870

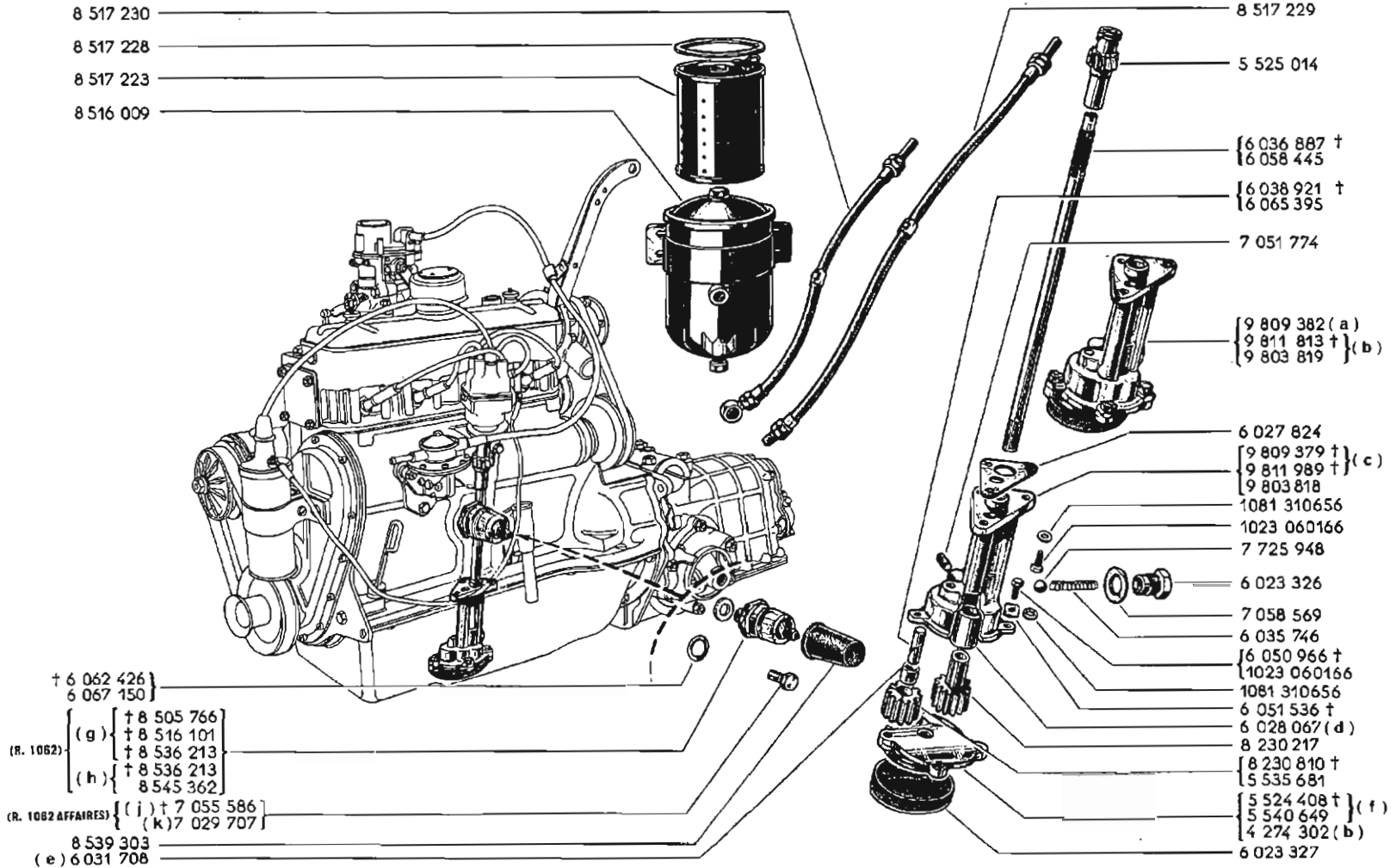

XXXX
00000

32		08-00
----	--	-------

	n°...	⇨	n°...	⚡	⚡	!!!
(a)	1	MOT	584308			
(b)	584309	MOT	...			
(c)						72
(d)	1	MOT	521994			
(e)	1	MOT	433204			
(f)	1	MOT	584308			73
(g)	1	VEH	532892		32	
(h)	532893	VEH	...	32		
(j)	1	MOT	911874			
(k)	911875	MOT	...			

!!!

72	⚖	1024 080256 -2- 8051538 -2-
73		06-00



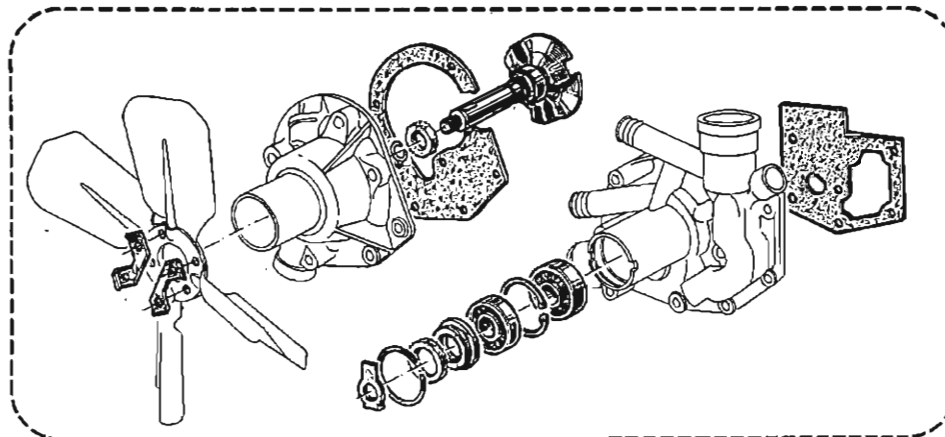

9 803 859 { (R. 1060) (R. 2070) (R. 2071)
(R. 1082) (a)

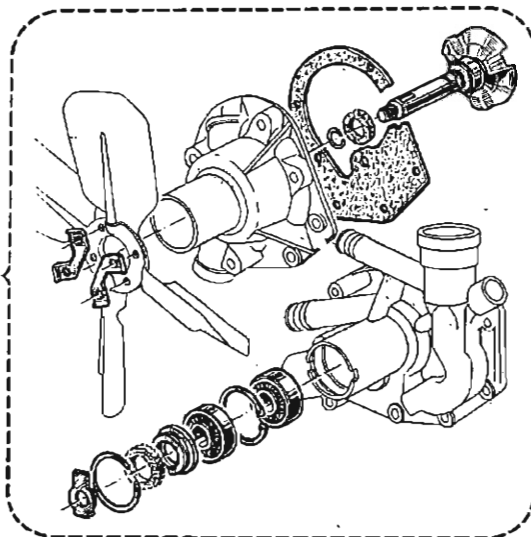

(b) 9 803 860

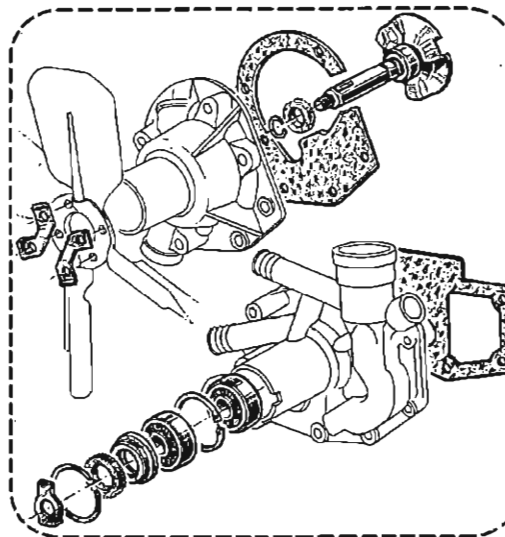

9 803 862 (c)

- (a) MOT n° 1 ⇨ MOT n° 625266
- (b) { MOT n° 625267 ⇨ MOT n° 791922
MOT n° 793001 ⇨ MOT n° 793335
- (c) { MOT n° 791923 ⇨ MOT n° 793000
MOT n° 793336 ⇨ MOT n° ...

17.01

A P.R. 685

(R. 1060) (R. 2070)

17.01

A P.R. 685

- 1023 060306
- 6 066 007
- 8 511 108
- 9 809 406
- † 6 030 959
- † 5 542 590
- 7 706 202
- 7 057 910
- 8 511 926
- 6 030 960
- 7 057 916
- 7 057 911
- 7 056 646
- 5 525 739
- † 6 052 106
- 1080 101040

- 6 030 958
- 6 030 969
- 6 030 957
- † 9 809 405
- (198) 9 811 927

- † 8 210 172
- † 8 210 700
- 8 212 208
- 6 060 812
- † 1023 080166
- 1023 380166
- 8 517 174

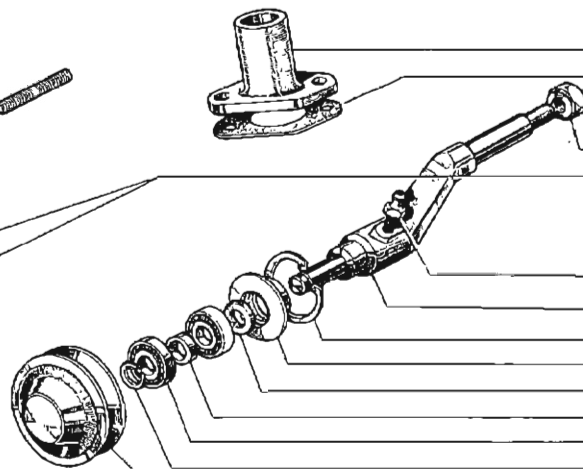
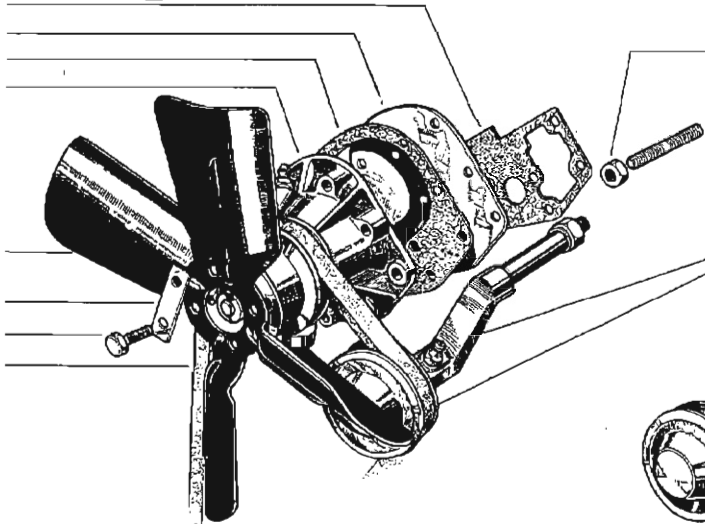
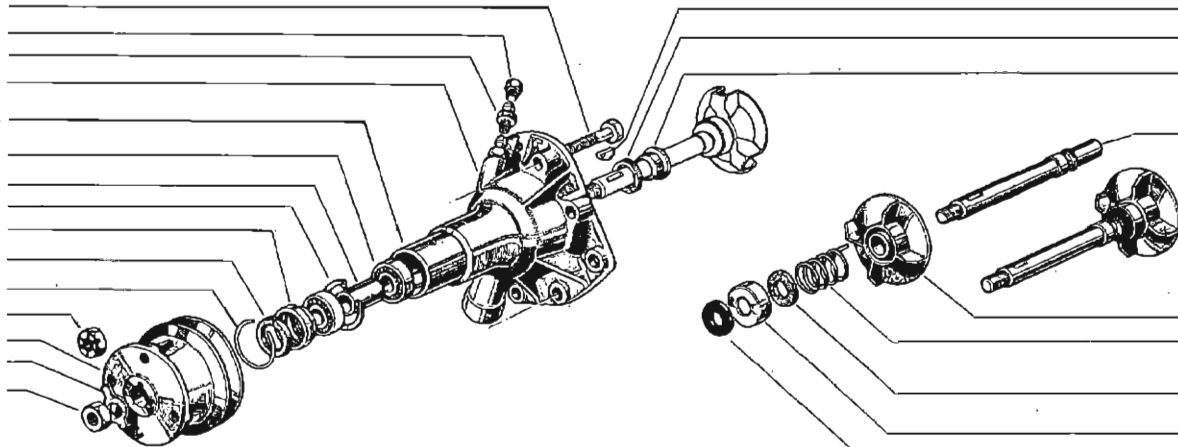



- 7 035 001
- 7 057 012
- { 6 034 272 †
- 6 035 221
- { 6 034 271 †
- 6 049 646 † (39)
- { 9 811 099 †
- 9 811 440 † (39)



- 6 035 109
- 6 035 218 (3)
- { 6 035 125 †
- 6 035 828 †
- 6 049 165
- 6 035 001
- 6 035 126
- 1080 100656



- 6 029 855
- { 6 029 854 †
- 6 058 375
- 6 006 487
- 9 809 504

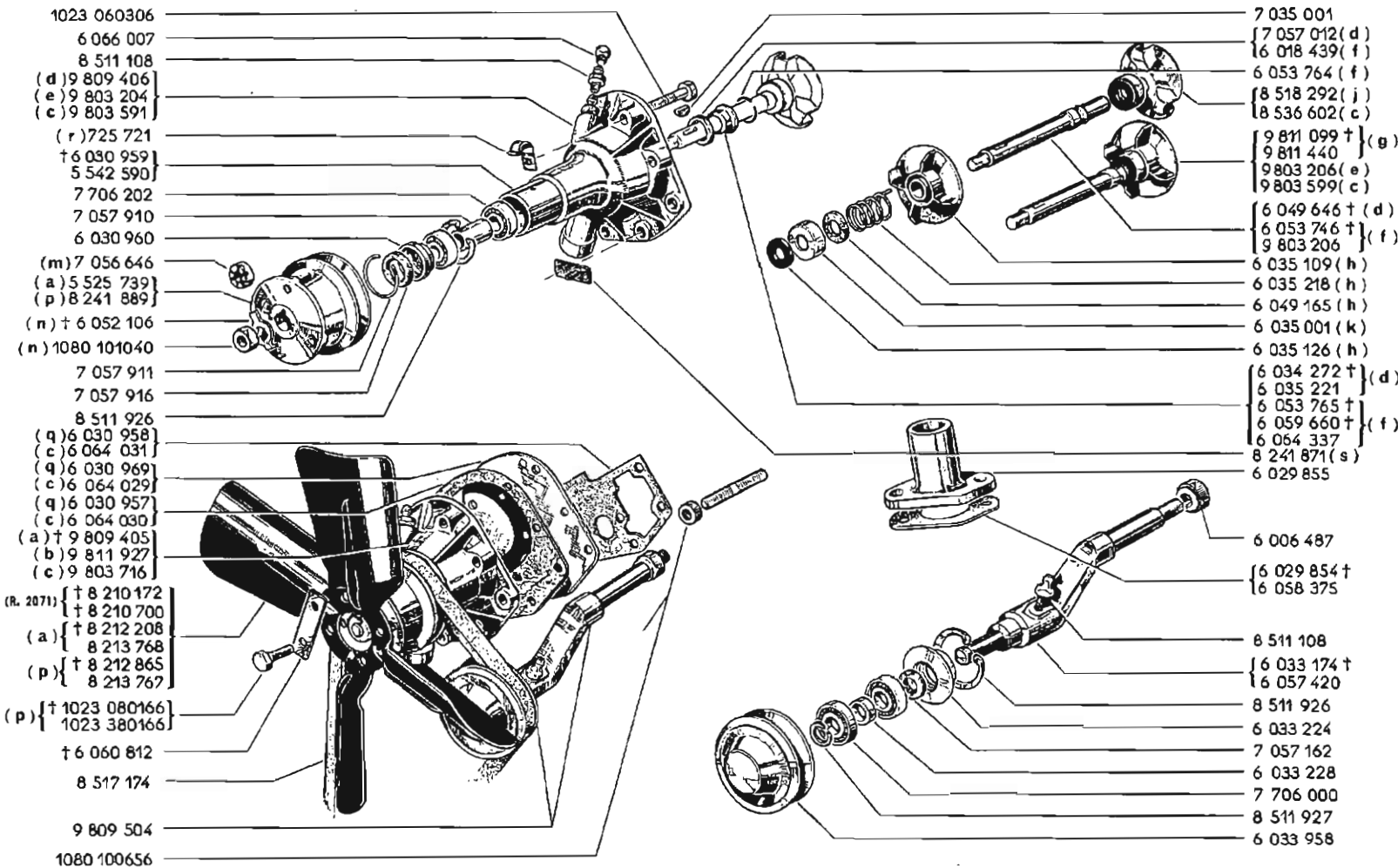

- 8 511 108
- { 6 033 174 †
- 6 057 420
- 8 511 926
- 6 033 224
- 7 057 162
- 6 033 228
- 7 706 000
- 8 511 927
- 6 033 958

3		6035001 -1-
39		1080 101046 -1- 6052108 -1-
198		8212865 -1-



41	 
42	

	n°...	n°...		
(a)	1 MOT	724407		
(b)	724408 MOT	791922		198
(c)	791923 MOT	...		
(d)	1 MOT	625266		
(e)	625267 MOT	791922		
(f)	625267 MOT	...		
(g)	1 MOT	625266		39
(h)	1 MOT	53030	42	
(j)	144451 MOT	791922	41	
(k)	1 MOT	53030	42	74
(m)	1 MOT	403399		
(n)	403400 MOT	...		
(p)	724408 MOT	...		
(q)	1 MOT	791922		
(r)	420896 VEH	421100		
	422525 VEH	...		
(s)	397464 VEH	...		

39	 1080 101046 -1- 6052106 -1-
74	
198	 8212885 -1-



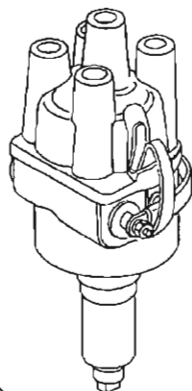
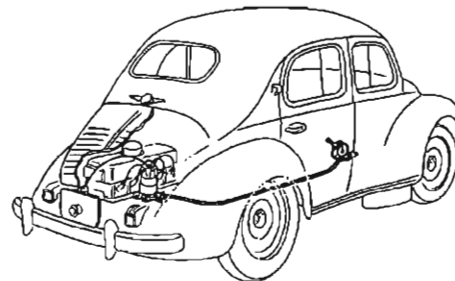
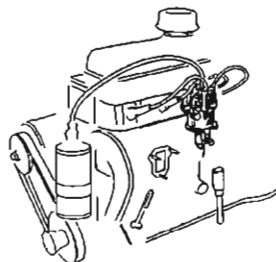

1024 060406

7 059 148

† 6 033 571
6 046 682

1080 100656

739 746

6 031 033

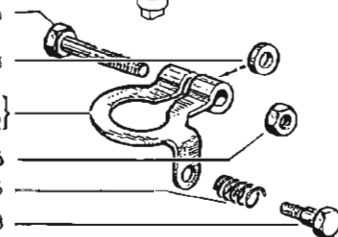

XXXX
00000

43

08-00

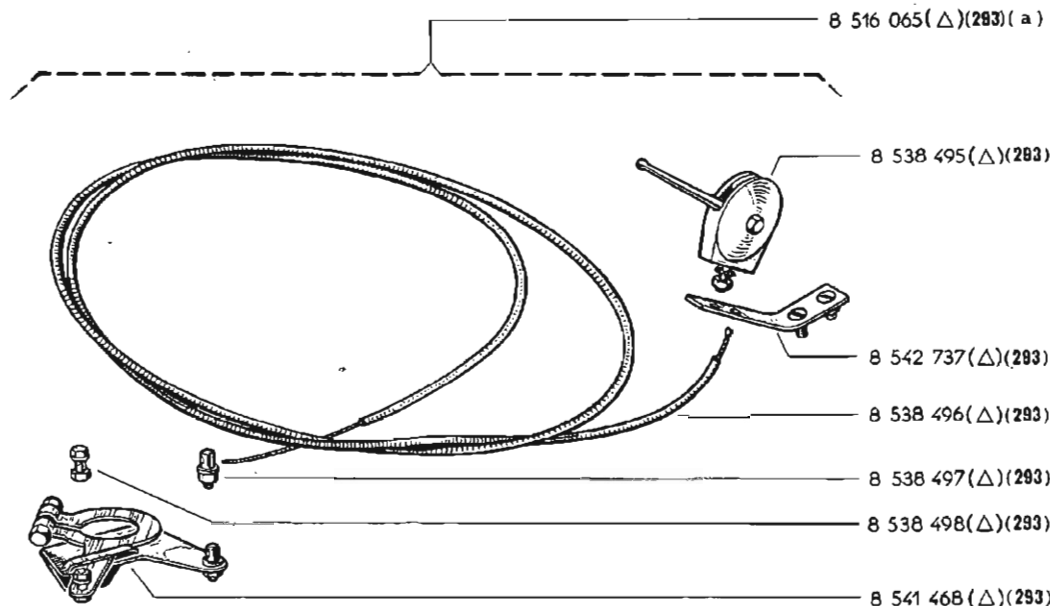

8 516 065 (Δ)(293) (a)

8 538 495 (Δ)(293)

8 542 737 (Δ)(293)

8 538 496 (Δ)(293)

8 538 497 (Δ)(293)

8 538 498 (Δ)(293)

8 541 468 (Δ)(293)

	XXXX 00000	!!!
n°...	n°...	⚡
(a)	1 VEH 869949 43	

293 08-00

8 515 555

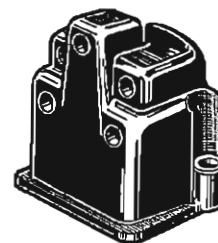
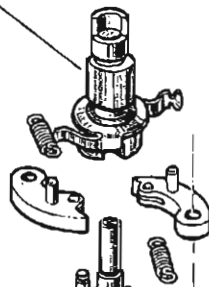
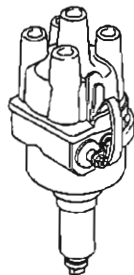

8 512 873

8 542 689

8 512 874

8 512 875

8 512 087

8 515 545

8 538 293

8 543 278

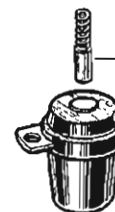
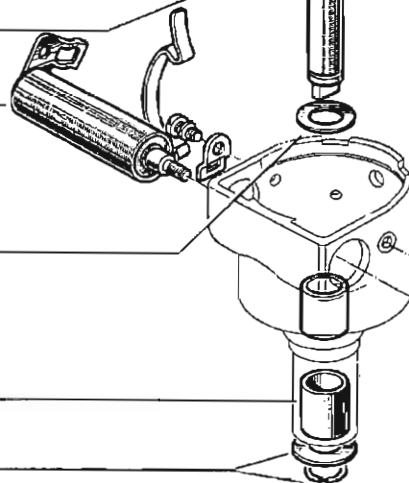

8 515 544

8 541 346

8 515 563

8 520 050

8 537 825

8 543 270

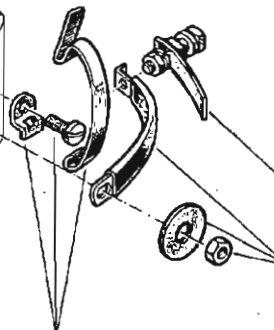

8 543 272

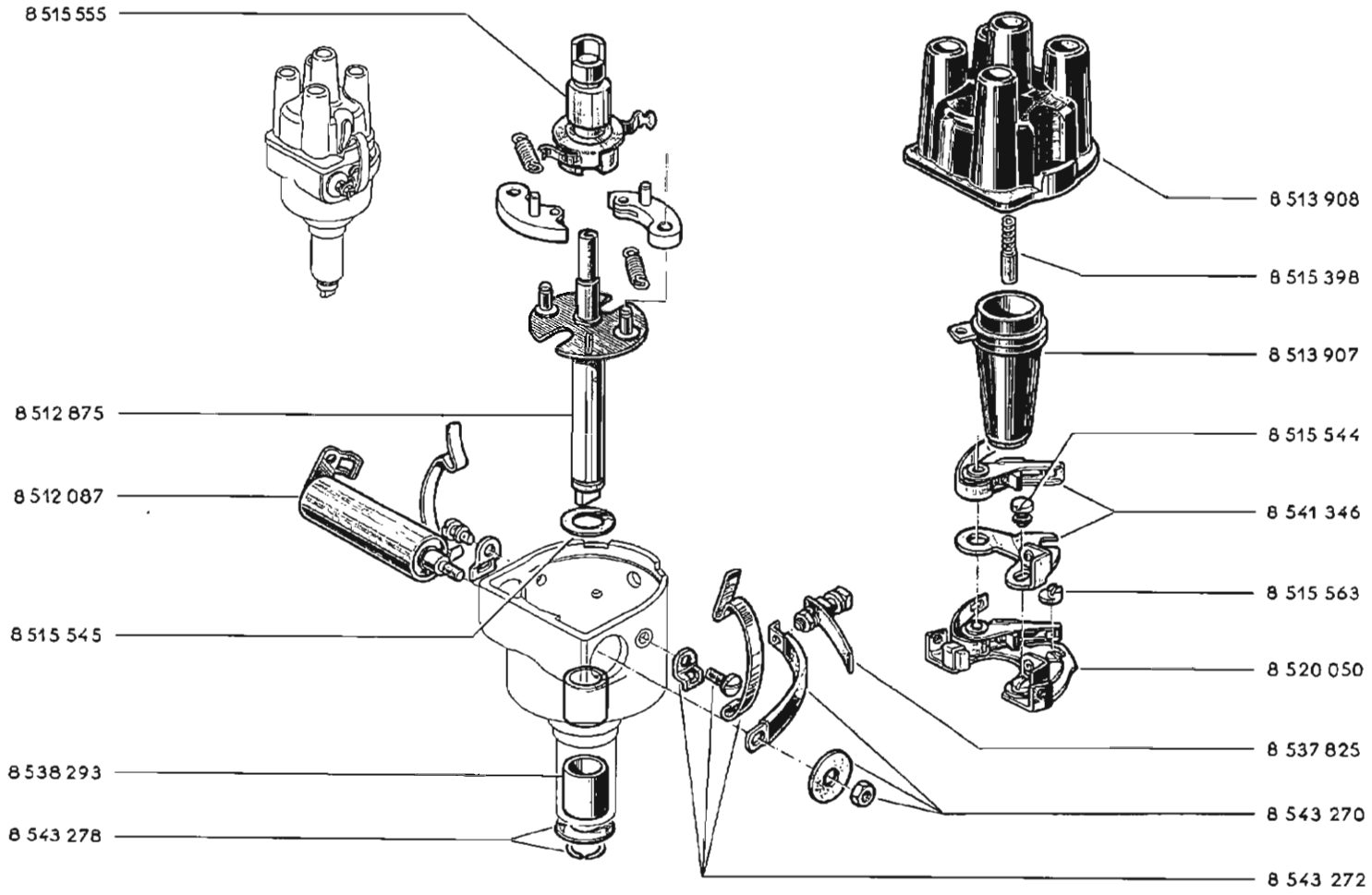

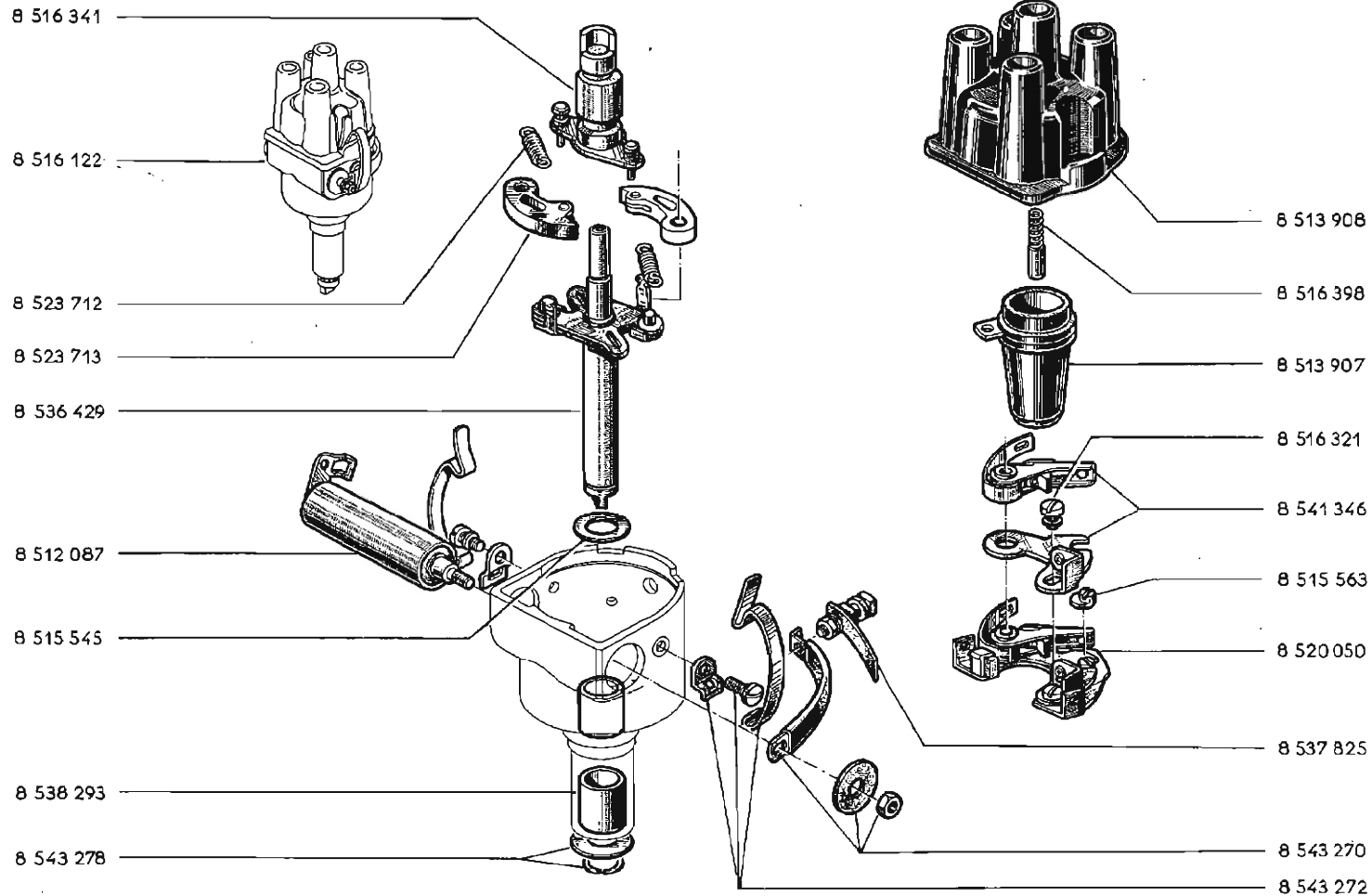



(a)

75	 06-00
154	 06-00

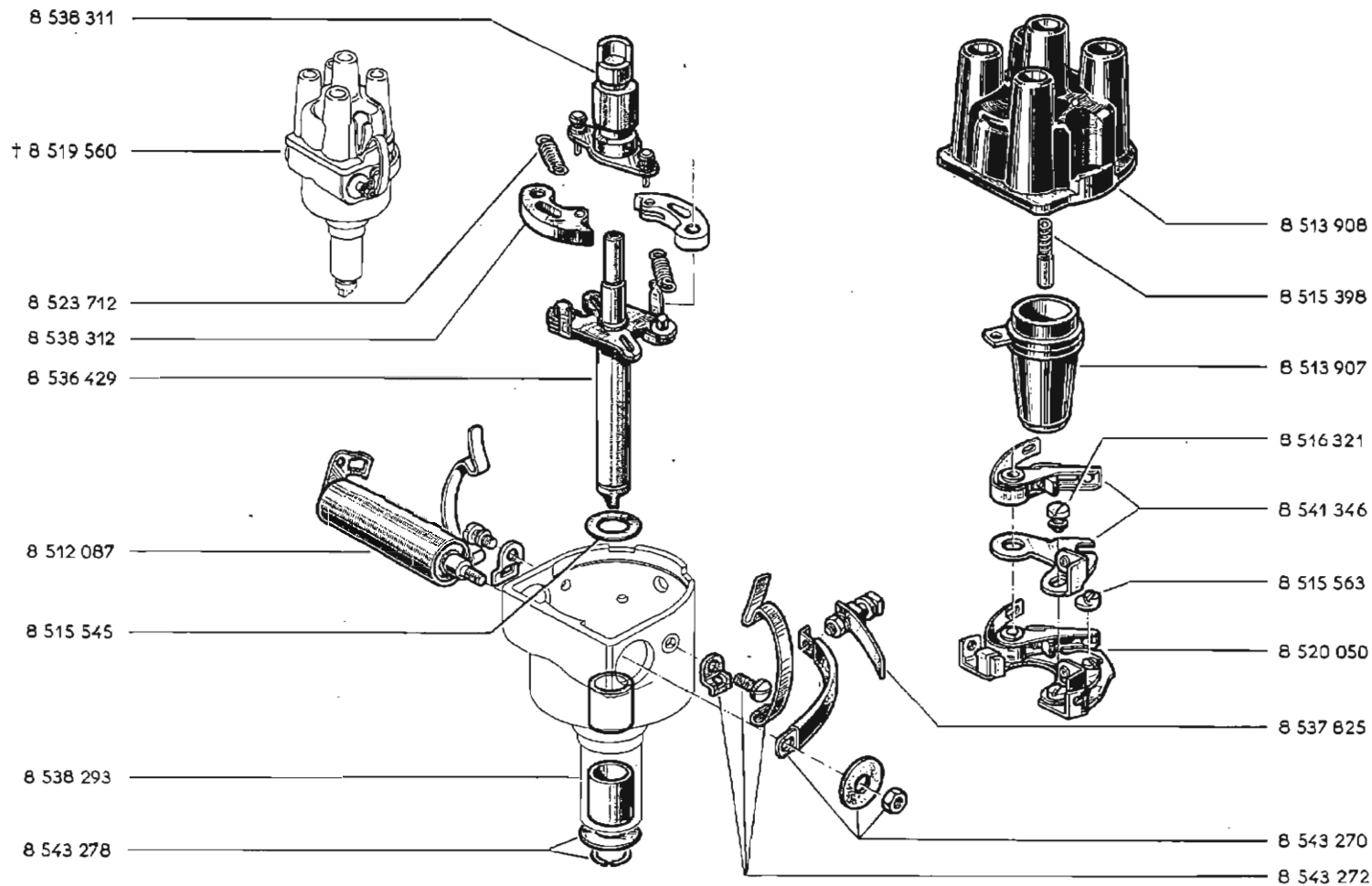

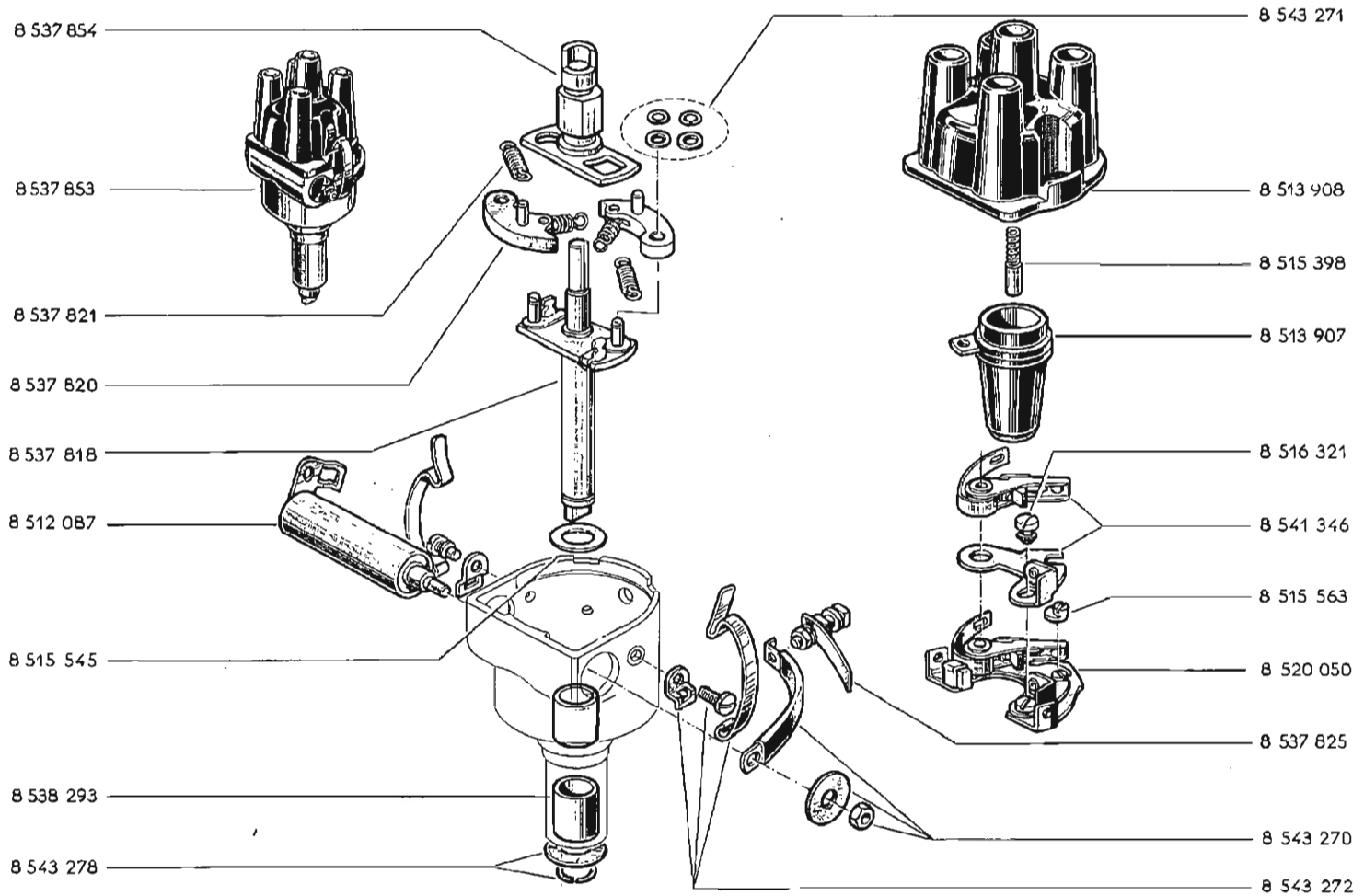

(a) VEH n° 299379 ⇔ VEH n° ...

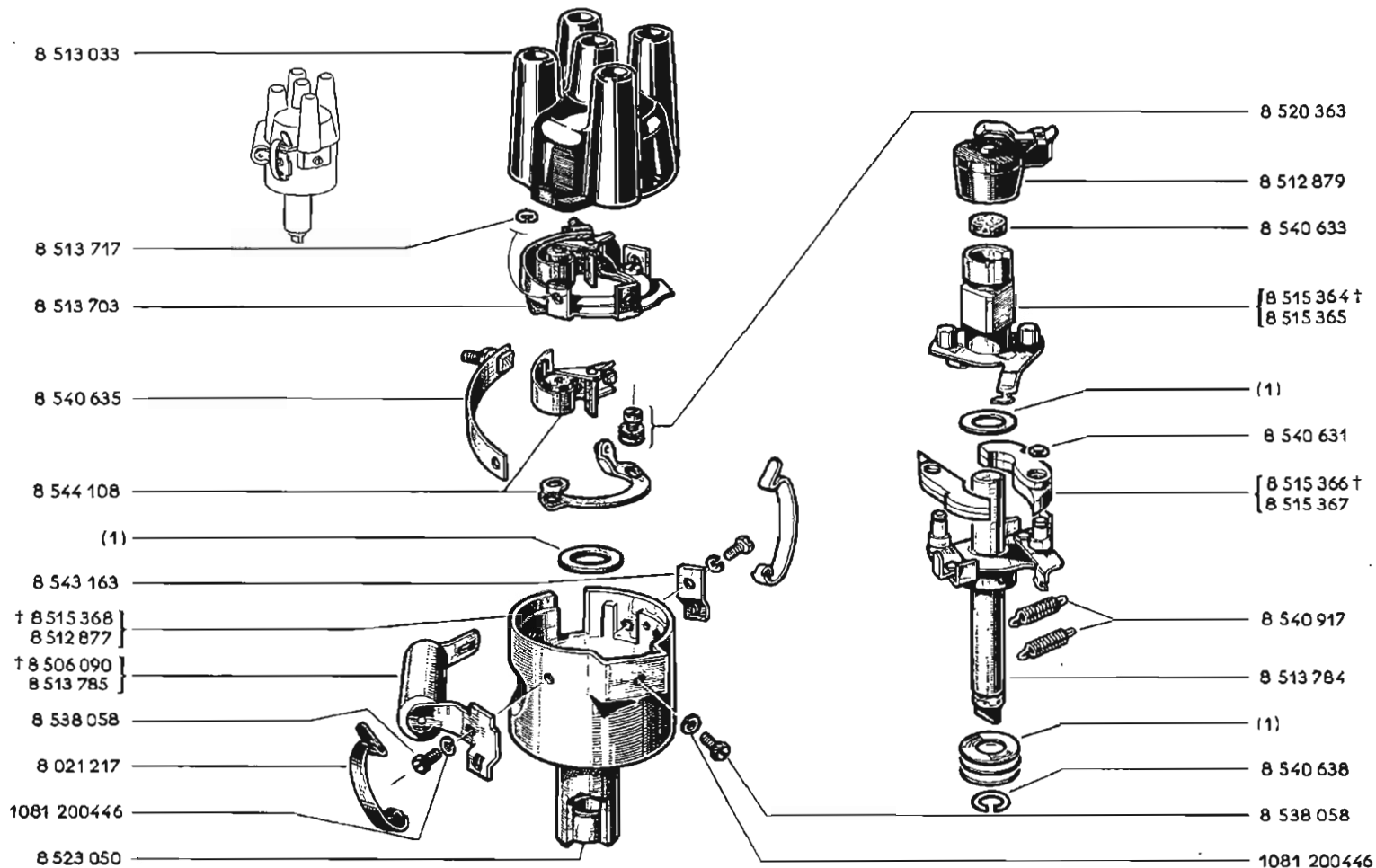

(1)

8540630	E = 0,3
8540637	E = 0,2

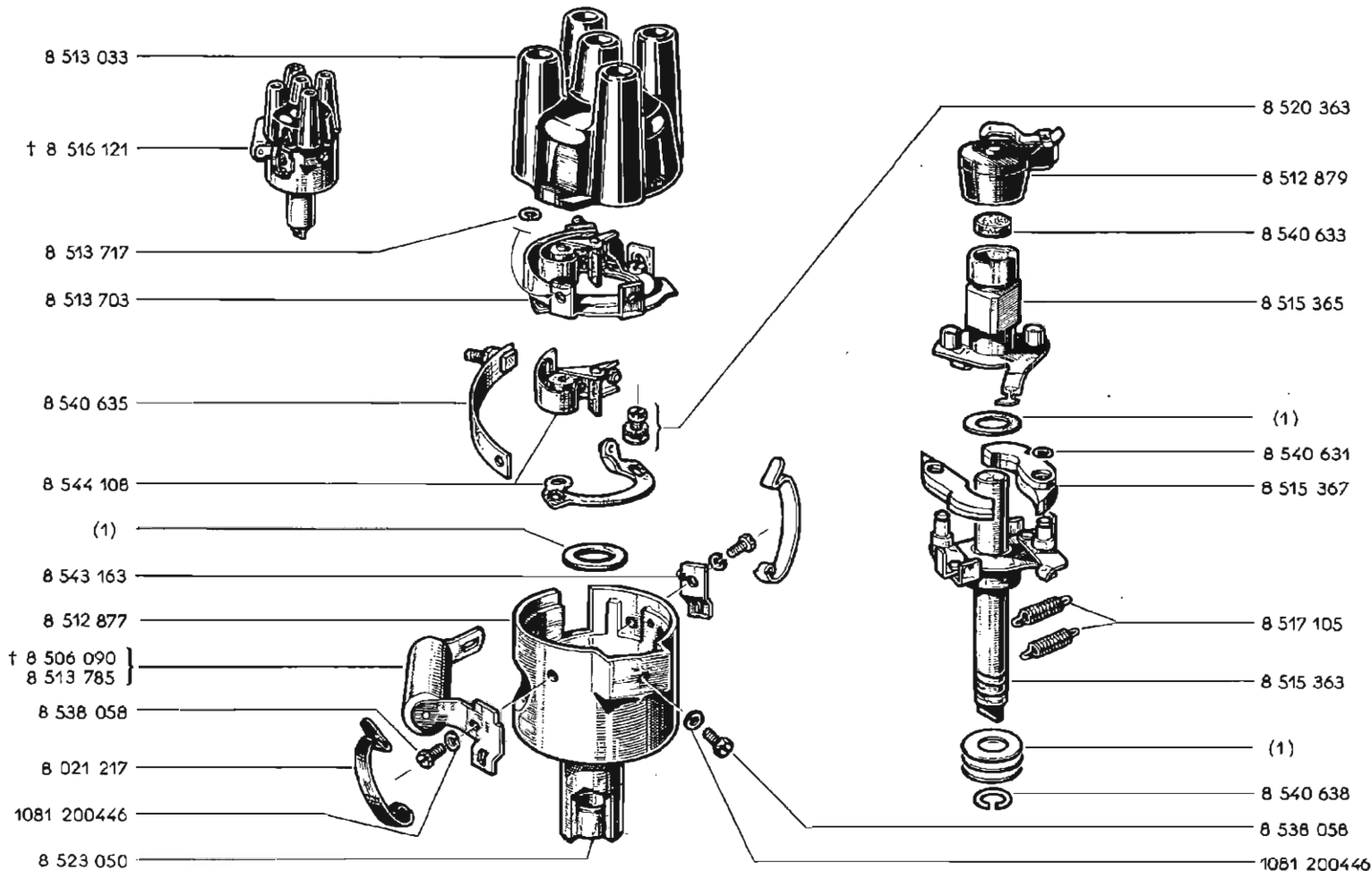

(1)
8540630 E=0,3
8540637 E=0,2

(a)	75	06-00
	154	06-00

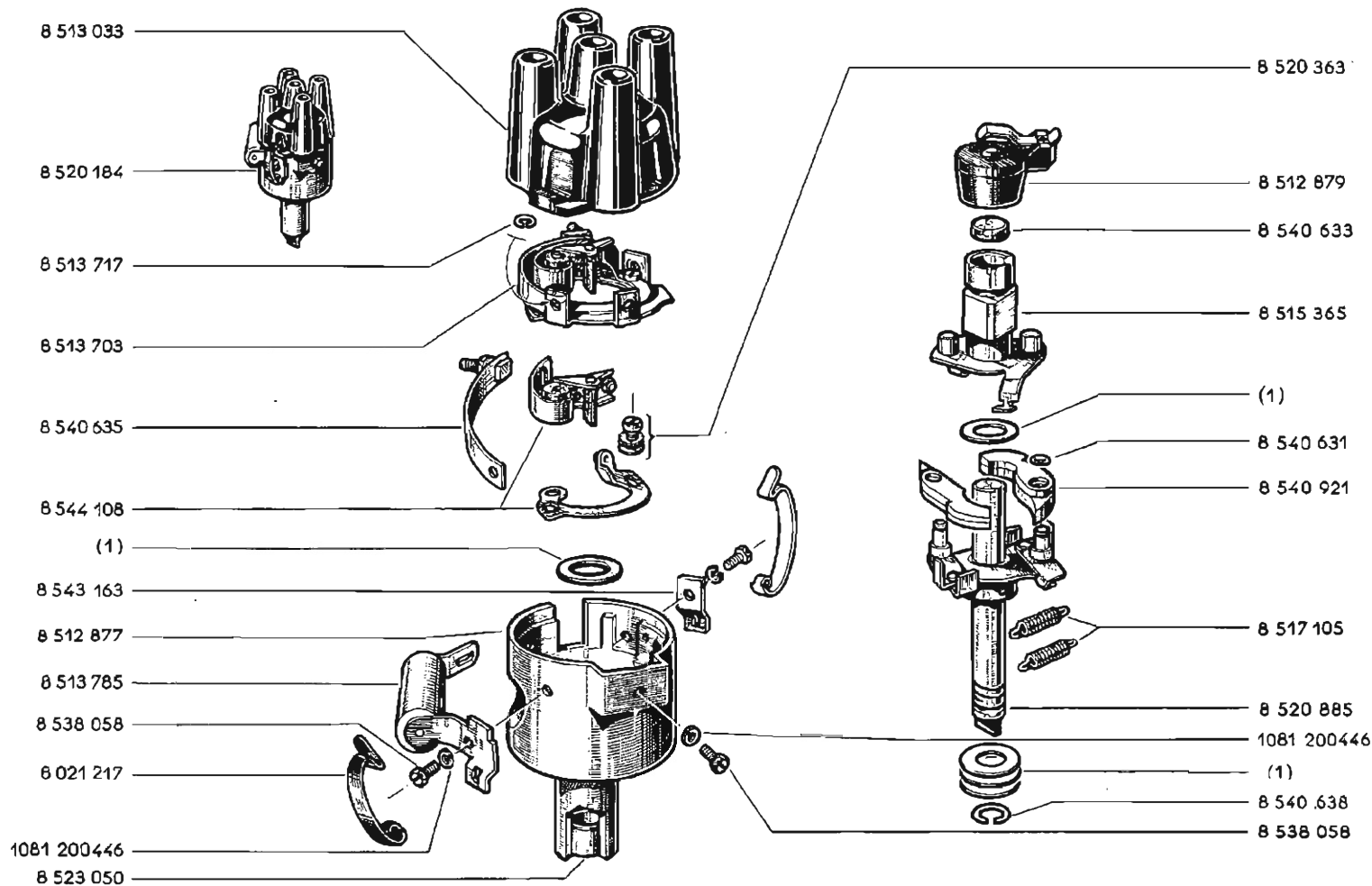

(1)
8540630 E=0,3
8540637 E=0,2

75	06-00
154	06-00

(b)	75	06-00
-----	----	-------

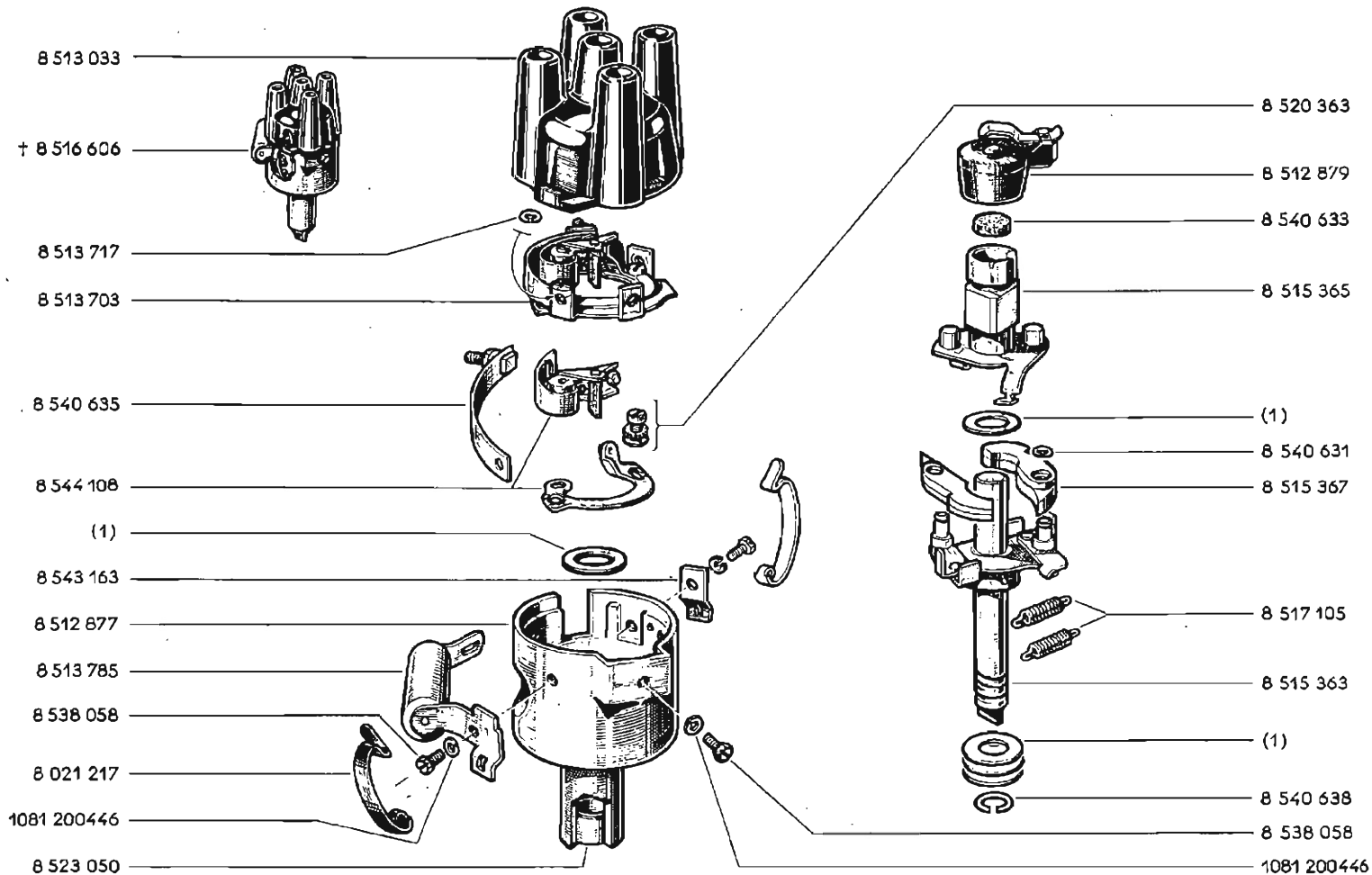

(1)
8540630 E=0,3
8540637 E=0,2

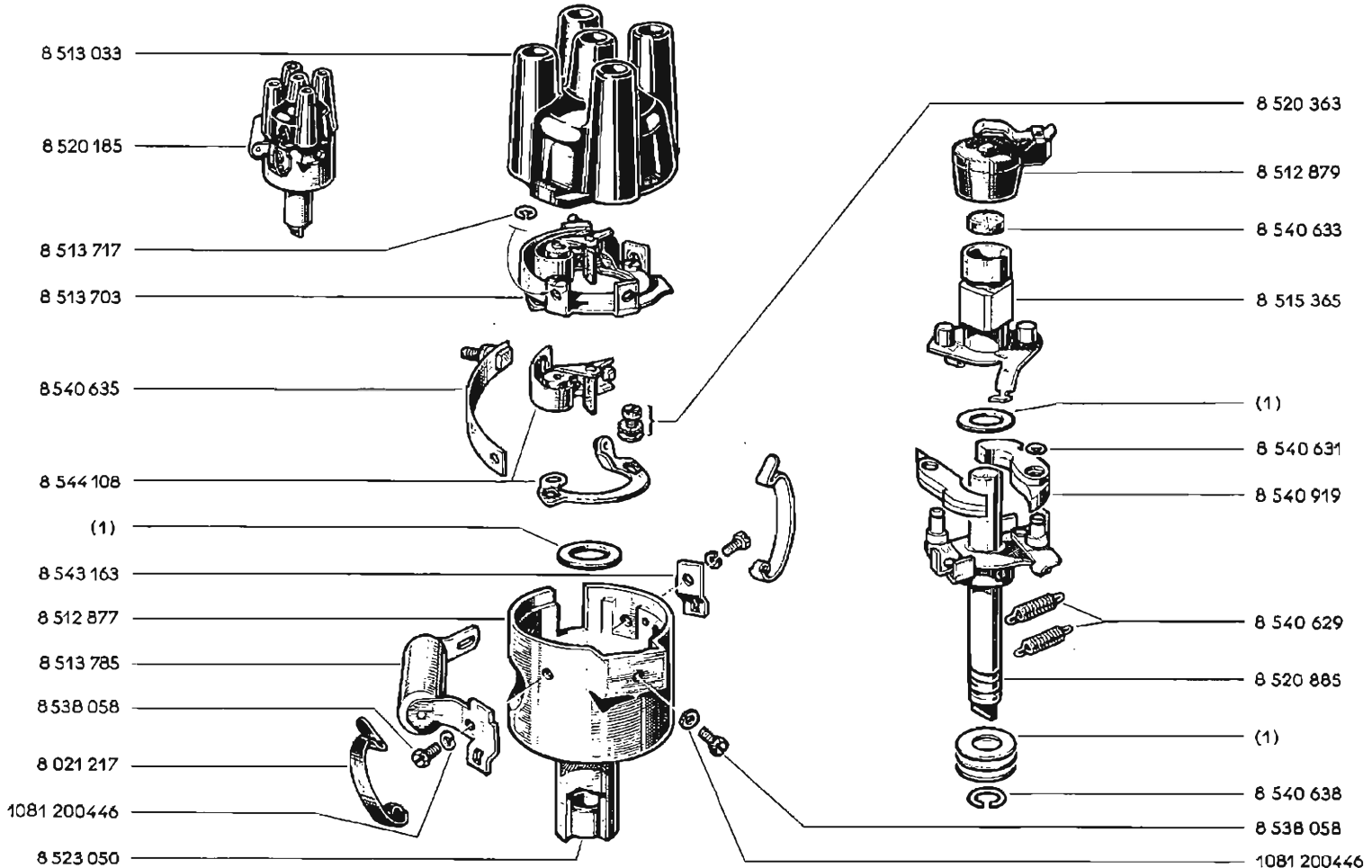

(1)
8540630 E = 0,3
8540637 E = 0,2

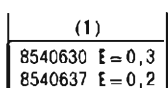
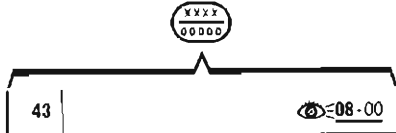
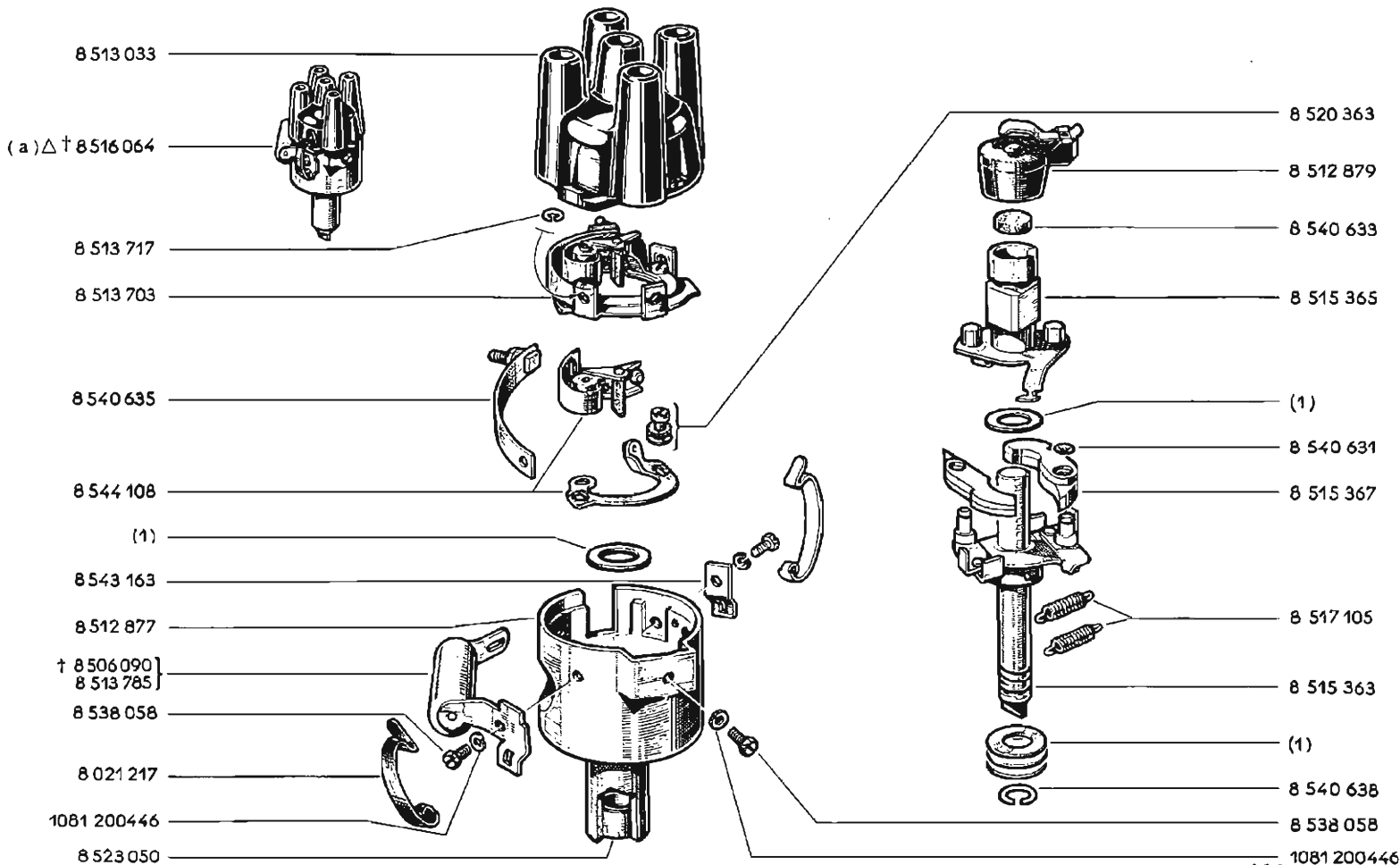

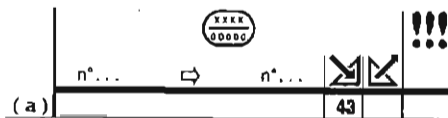
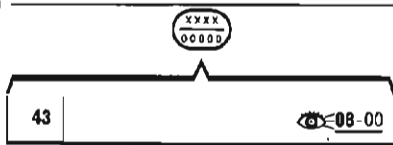
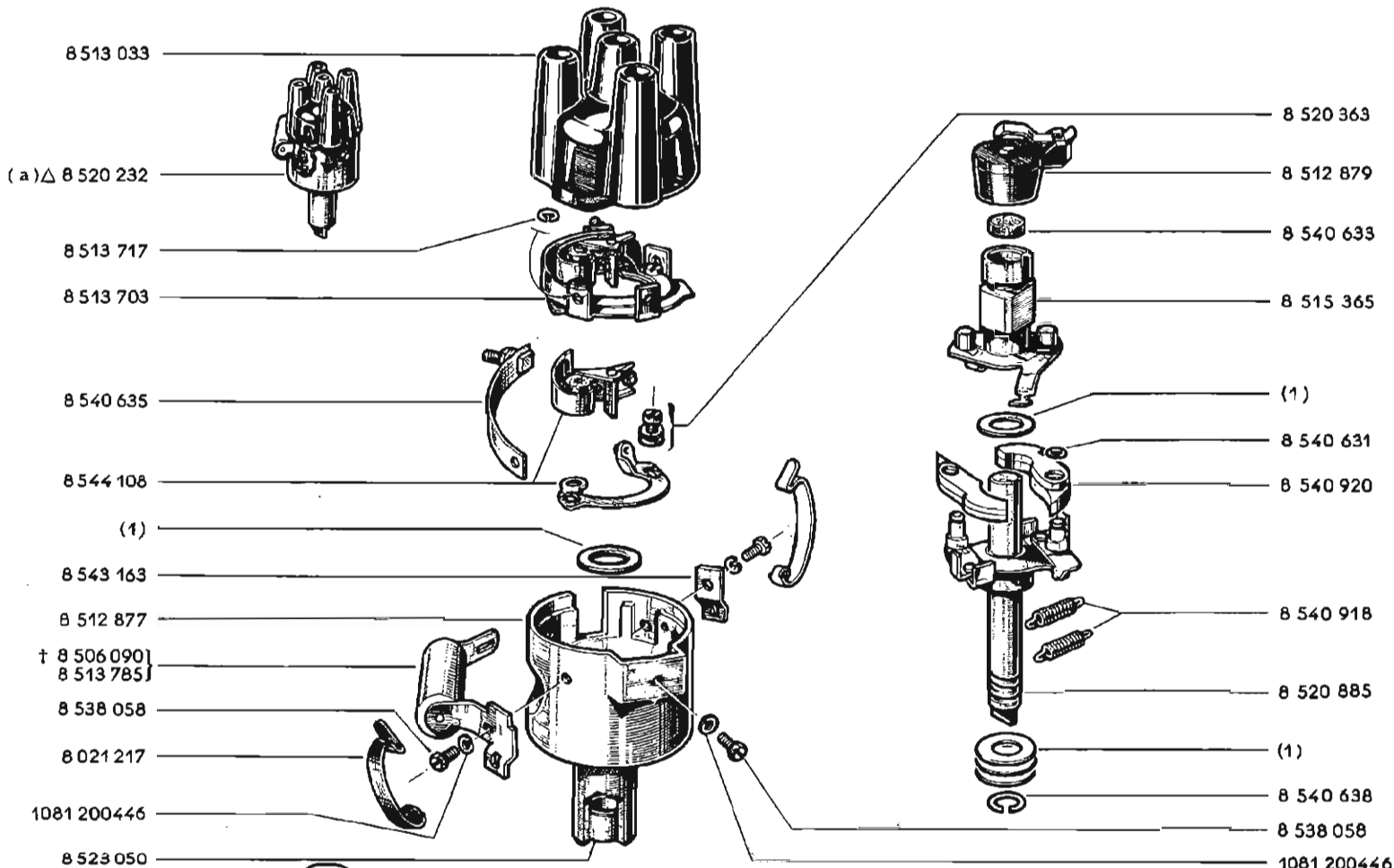

(1)
8540630 E=0,3
8540637 E=0,2

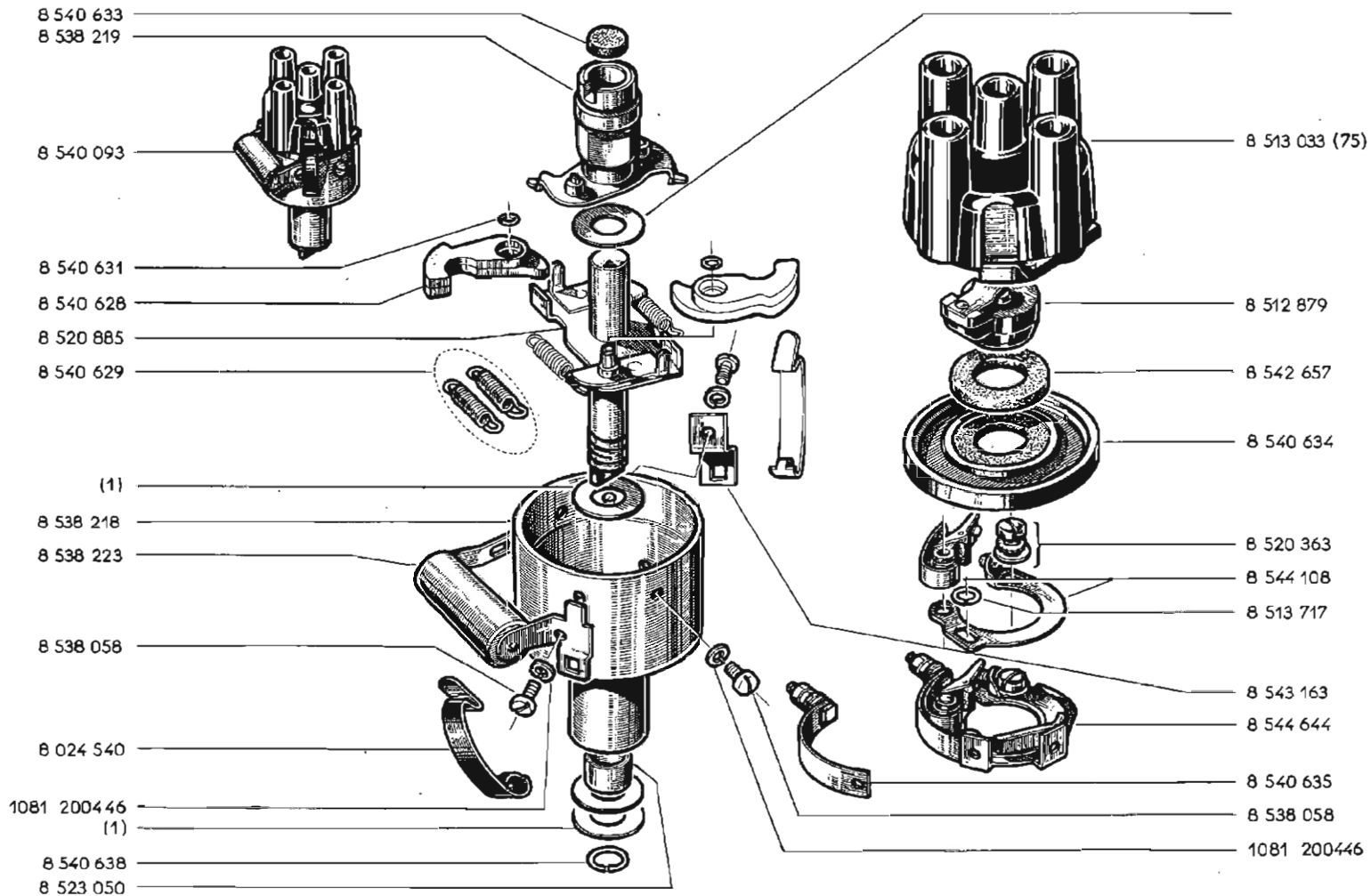

(1)
8540630 E=0,3
8540637 E=0,2

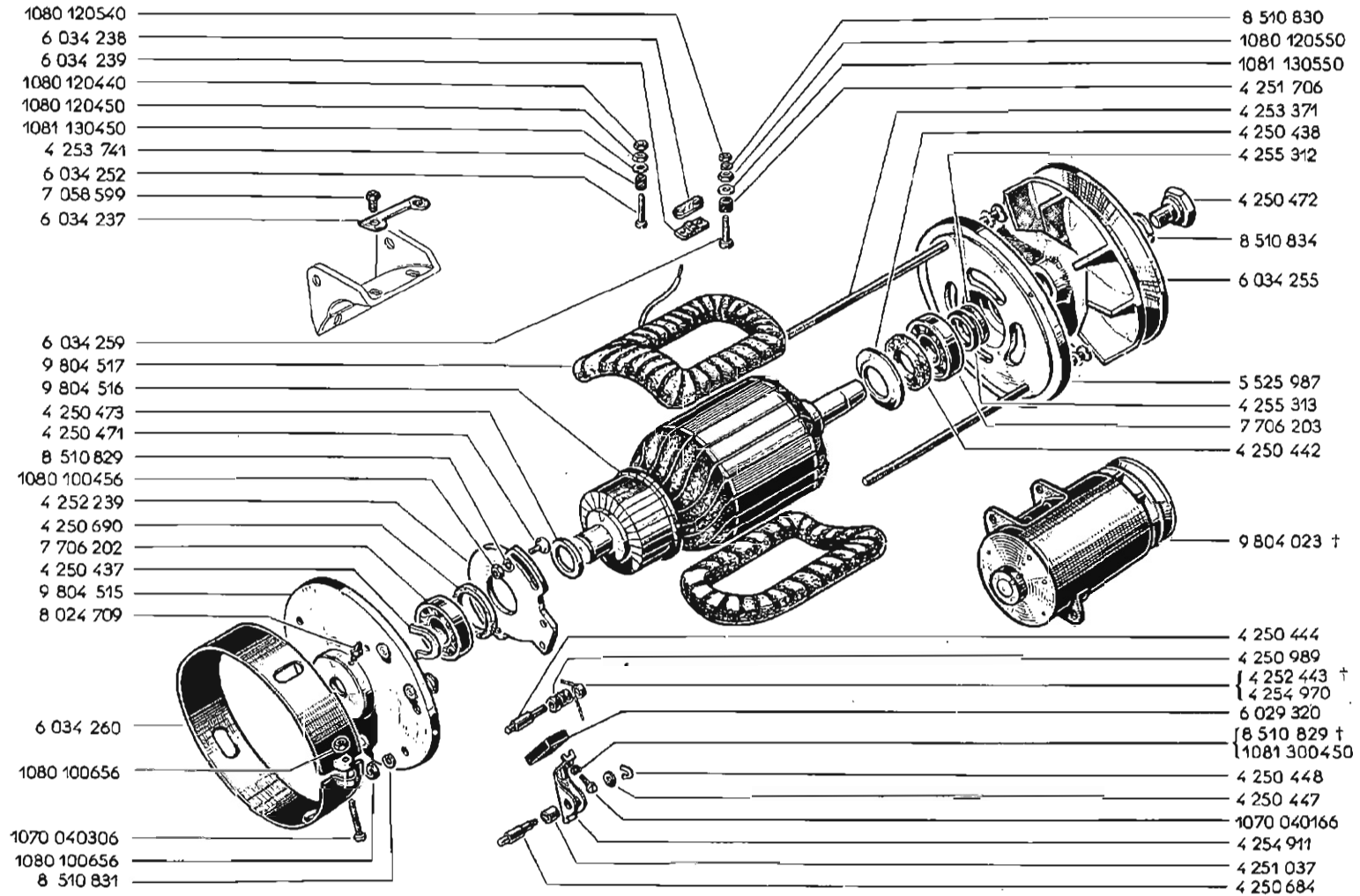

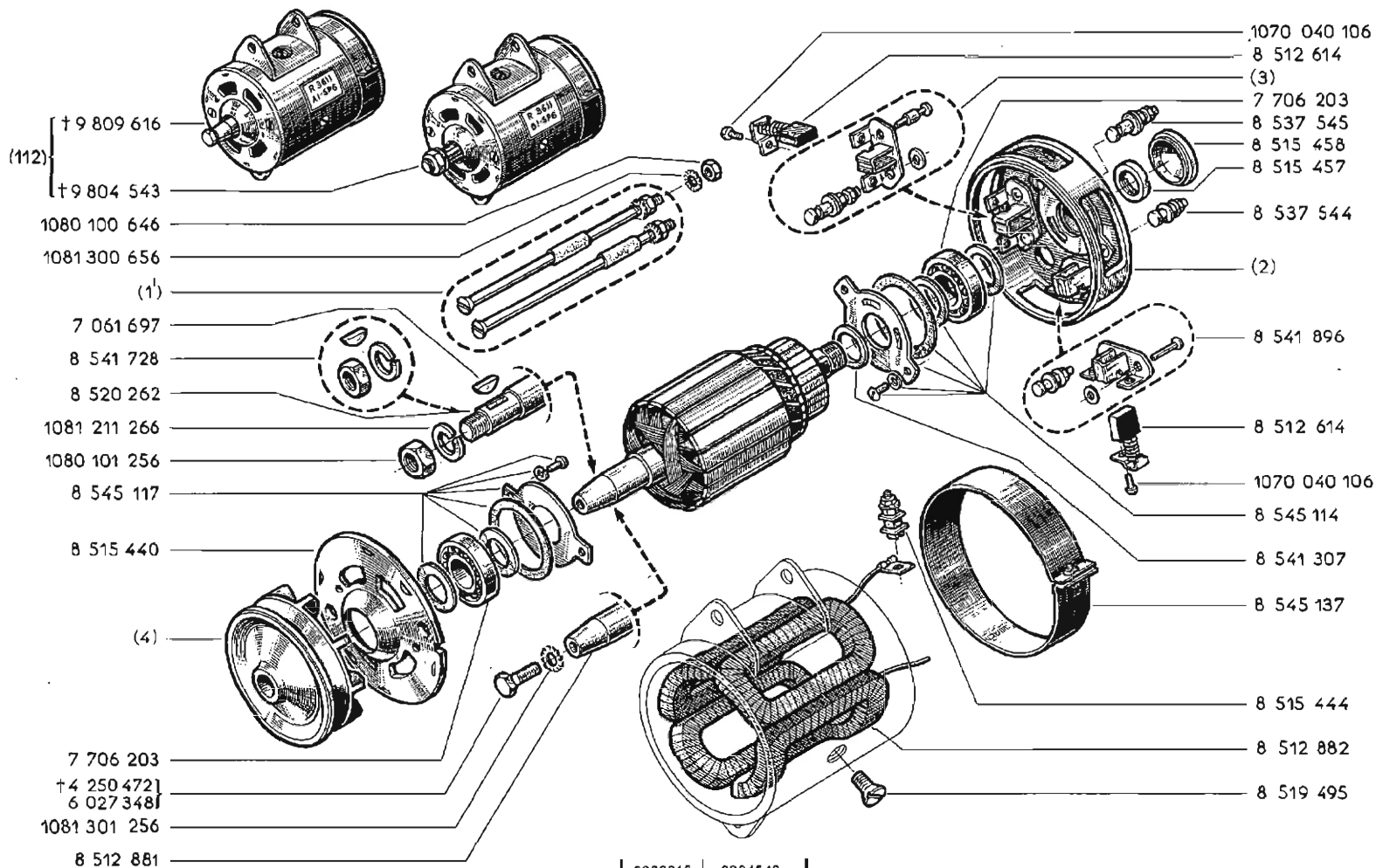

	9809616	9804543
(1)	8545136	8545107
(2)	8545134	8545115
(3)	8545135	8545116
(4)	6034265	† 6036240
		† 8535012

112 8034265 - 1 -

DUCELLIER 361-D1-SP6

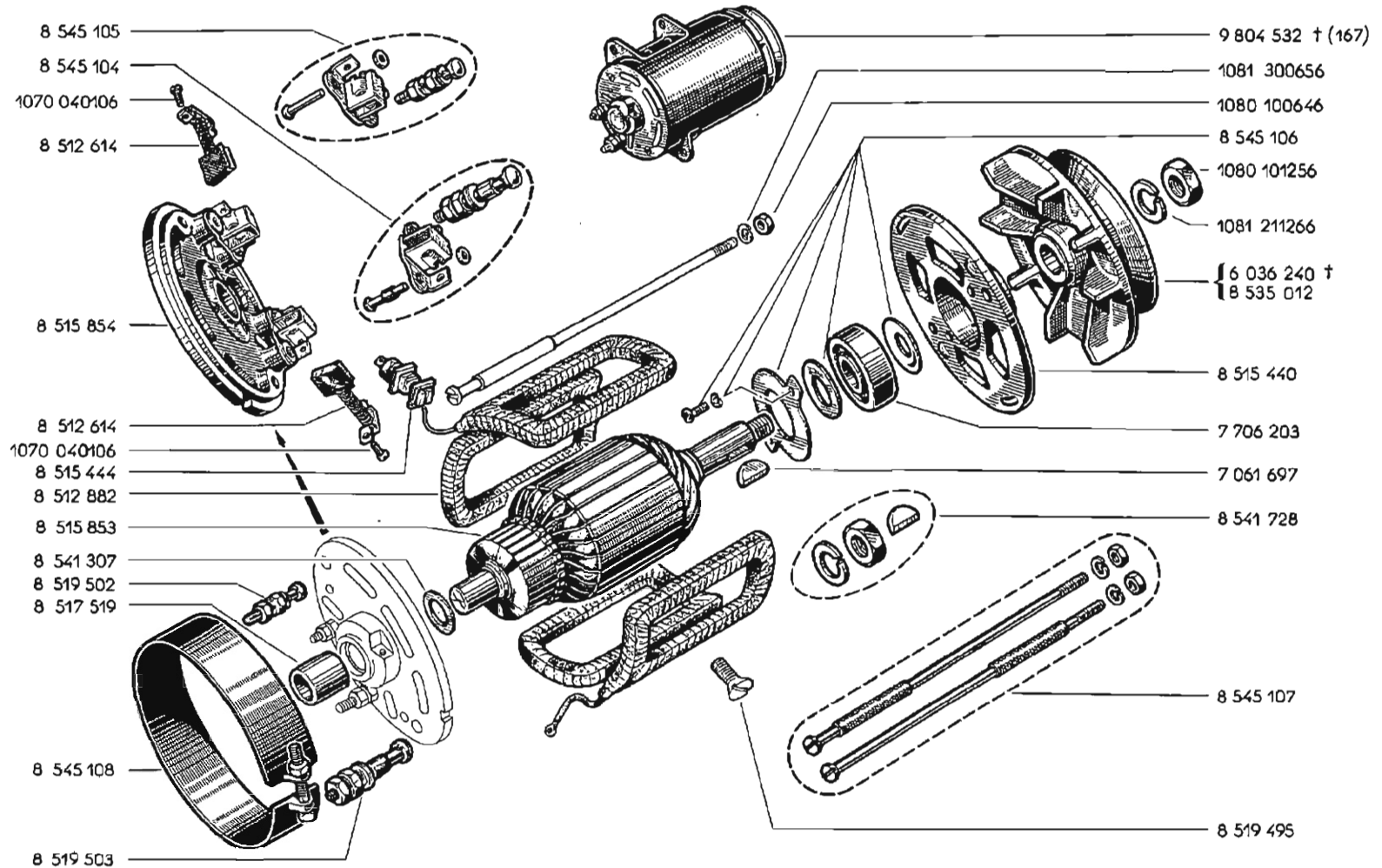

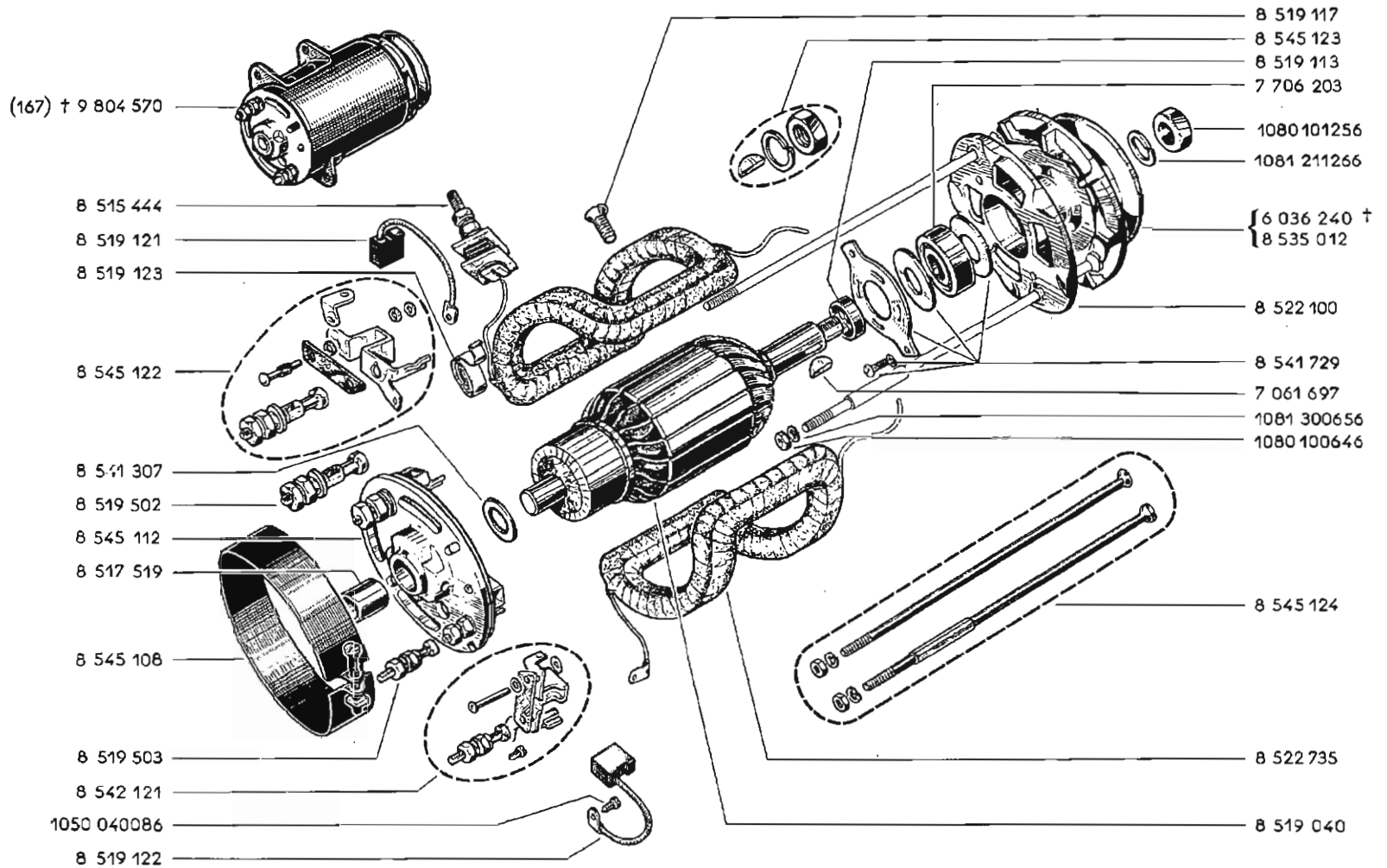

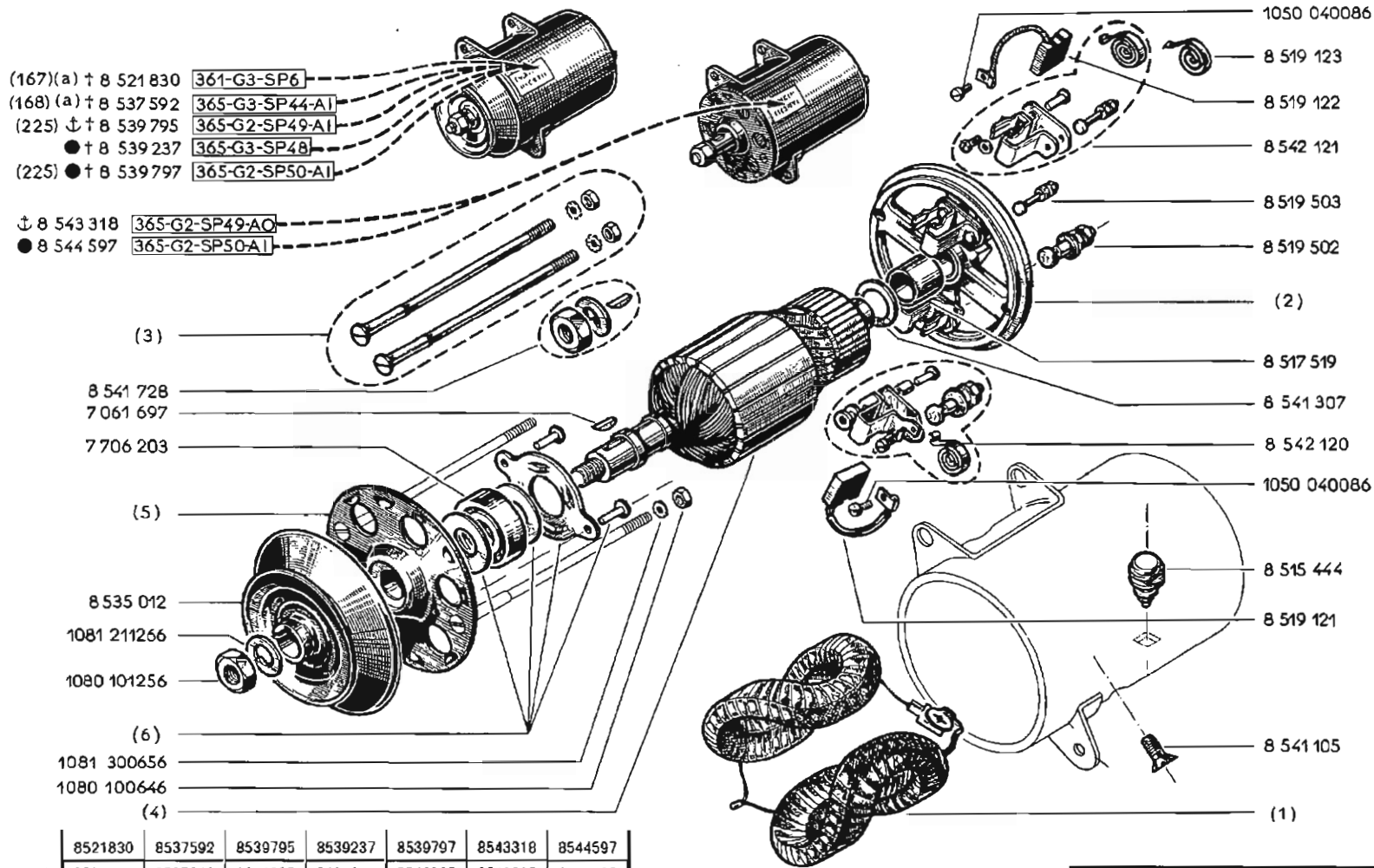



(a) VEH n° 1 ⇔ VEH n° 705121

	8521830	8537592	8539795	8539237	8539797	8543318	8544597
(1)	8522735	8537840	8540235	8537840	8540235	8540235	8540235
(2)	8522736	8537841	8542119	8542119	8542119	8537841	8542119
(3)	8545119	8541730	8541730	8541730	8541730	8541730	8541730
(4)	8519040	8519040	8519507	8519040	8519507	8519507	8519507
(5)	8522100	8522100	8522100	8540239	8540239	8522100	8540239
(6)	8541729	8541729	8541729	8541887	8541887	8541729	8541887

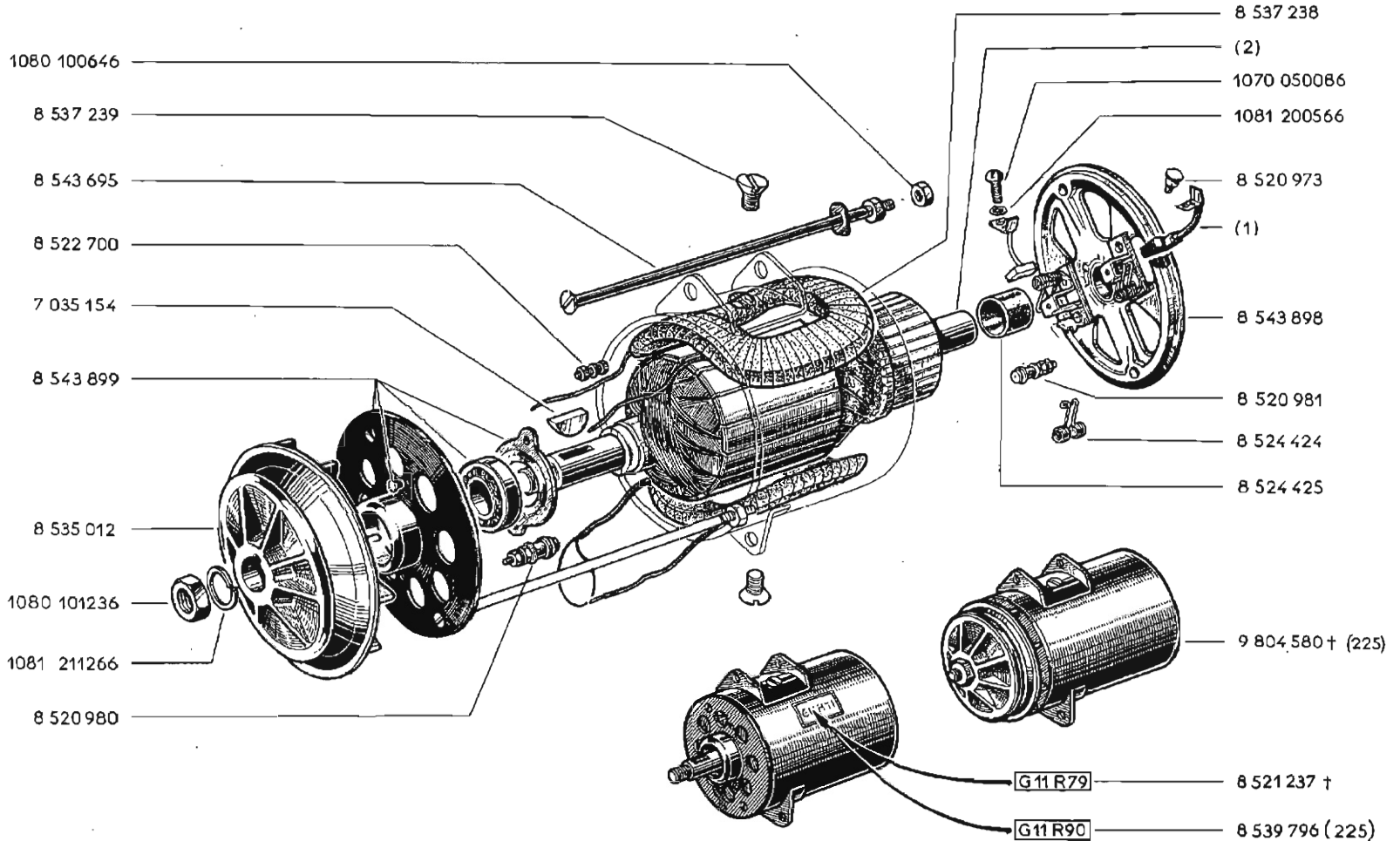
167	†	8535012 -1-
168		Ⓢ-06-00
225		Ⓢ-06-00



	8521237	8539796	9804580
(1)	8537241	8537246	8537246
(2)	8537235	8537244	8537244

225  06-00

(c) LO=17 Renault 6 034 864
 (b) LO=21 Ducellier 6 036 137

(a) LO=15 6 034 257
 (b) LO=11 6 036 136

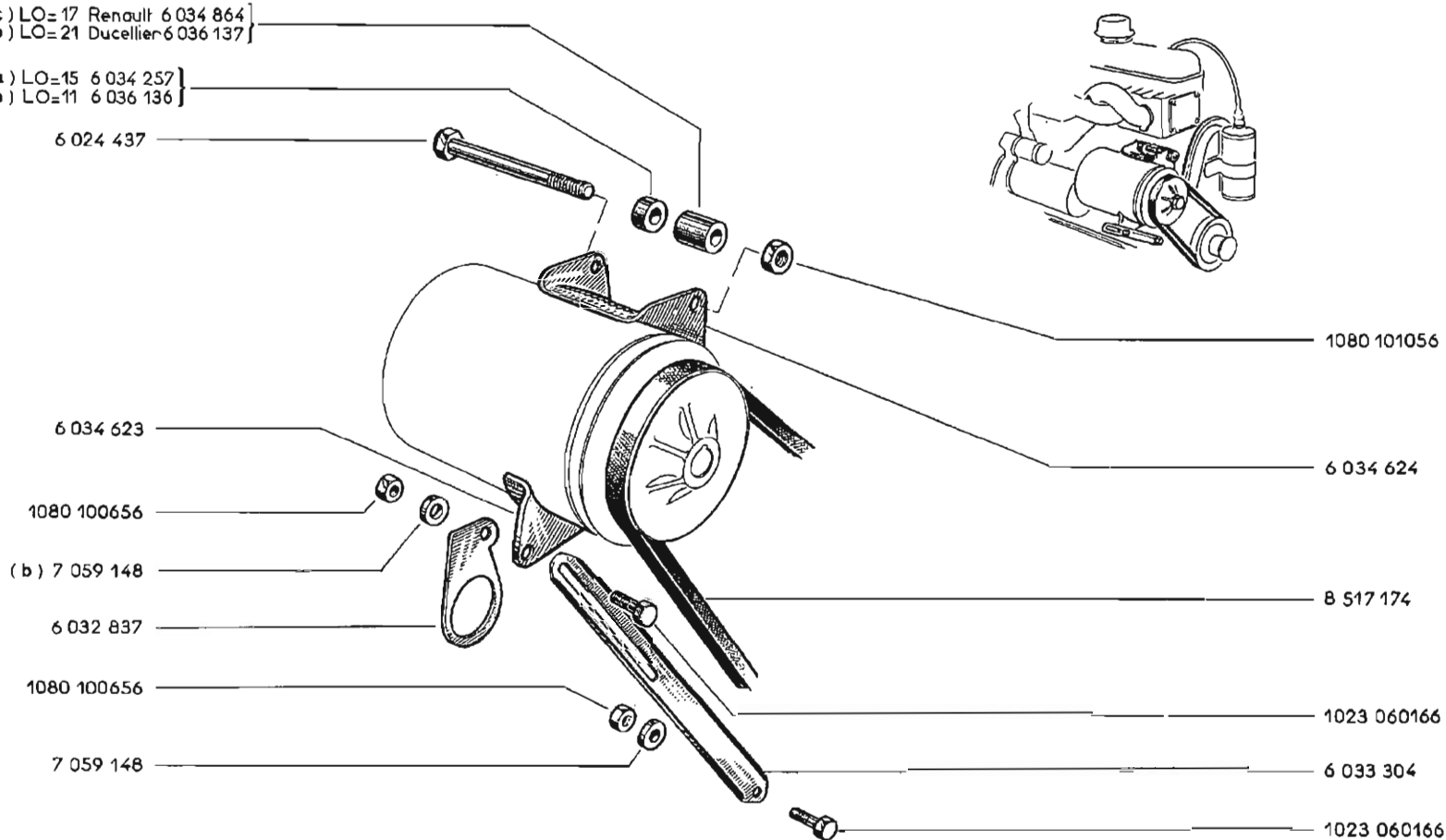

(a) MOT n° 1 ⇨ MOT n° 35529
 (b) MOT n° 35530 ⇨ MOT n° ...
 (c) MOT n° 725 ⇨ MOT n° ...

A P.R. 685

A P.R. 685

- 6 031 225
- 8 511 967
- 9 805 520
- 4 252 361
- 4 252 360
- 1081 200866
- 4 256 766
- † 9 805 509
- 9 805 594
- 1023 080256
- 6 029 040
- 6 029 042
- 6 029 041
- 9 805 519
- 1024 050106
- † 9 805 514
- 8 522 973
- 6 029 896
- † 9 805 513
- 8 240 399
- 6 031 270
- 8 522 977
- 7 057 989
- 7 059 772
- 4 253 585
- 4 252 472
- 8 522 978
- 6 024 570
- 8 240 020
- 8 521 228
- 7 057 988
- † 9 805 010
- † 7 058 713
- 6 037 814
- 9 805 515
- 7 058 711
- 7 058 713
- 4 250 649
- 9 805 516
- 6 030 070
- 4 250 643
- 4 250 642

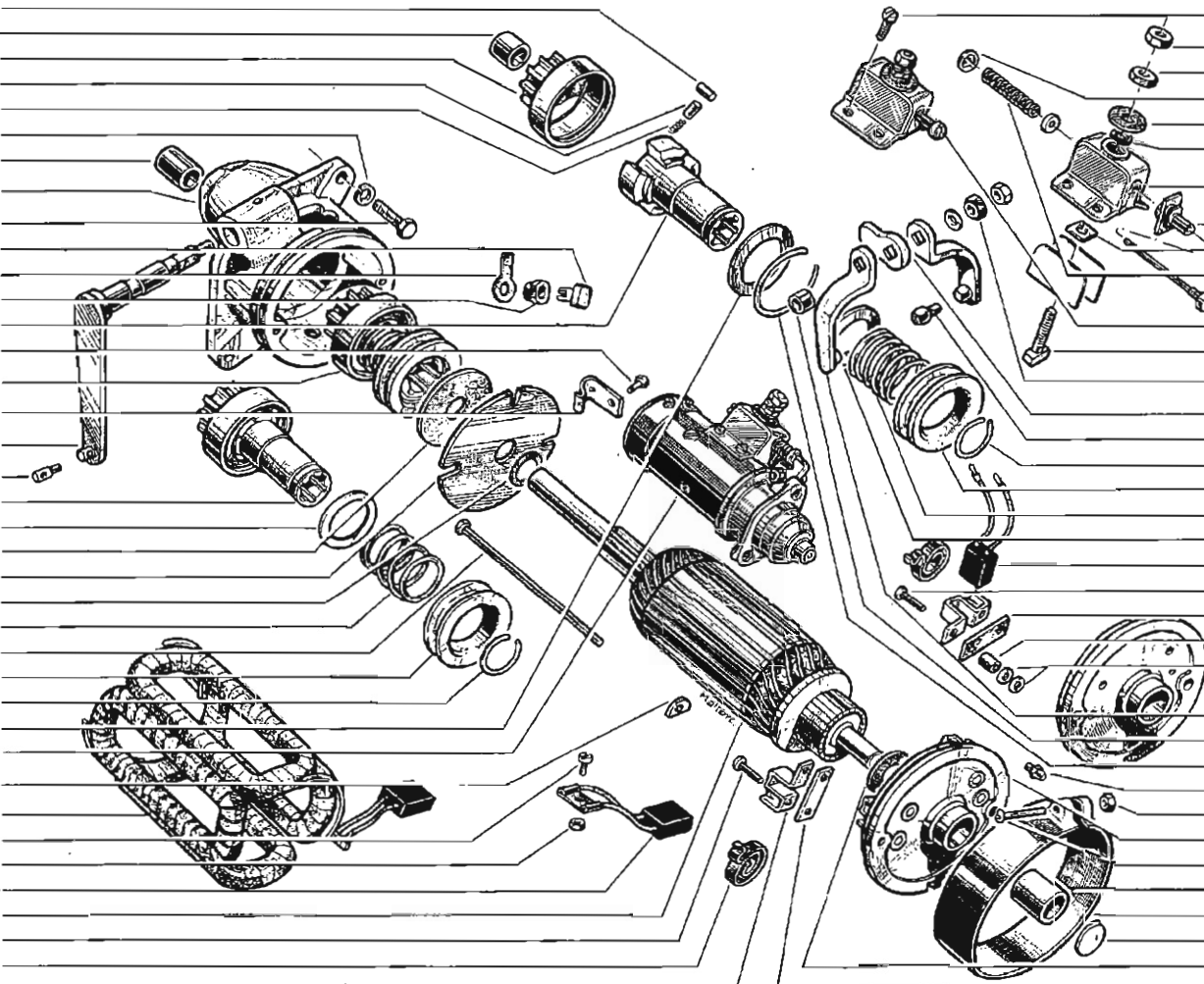

- 7 059 136 †
- 7 059 434
- 1080 100852
- 1080 100832
- 7 057 394
- 4 253 746
- 4 250 044
- 6 029 034
- 9 805 517
- 6 029 038
- 7 057 393
- 6 029 032
- 9 805 951
- 6 029 036
- 6 029 049 †
- 1080 100656
- 6 029 046
- 4 252 357
- 4 252 359
- 8 240 020
- 7 056 577
- 7 057 989
- 4 250 647
- 6 033 352
- 4 250 638
- 5 525 409
- 4 250 899
- 5 525 410
- 9 805 512
- 7 057 392
- 7 057 990
- 8 512 995
- 1080 100456
- 9 805 510
- 7 058 744
- 5 525 395
- 4 253 760
- 4 253 793
- 4 253 582
- 4 250 640

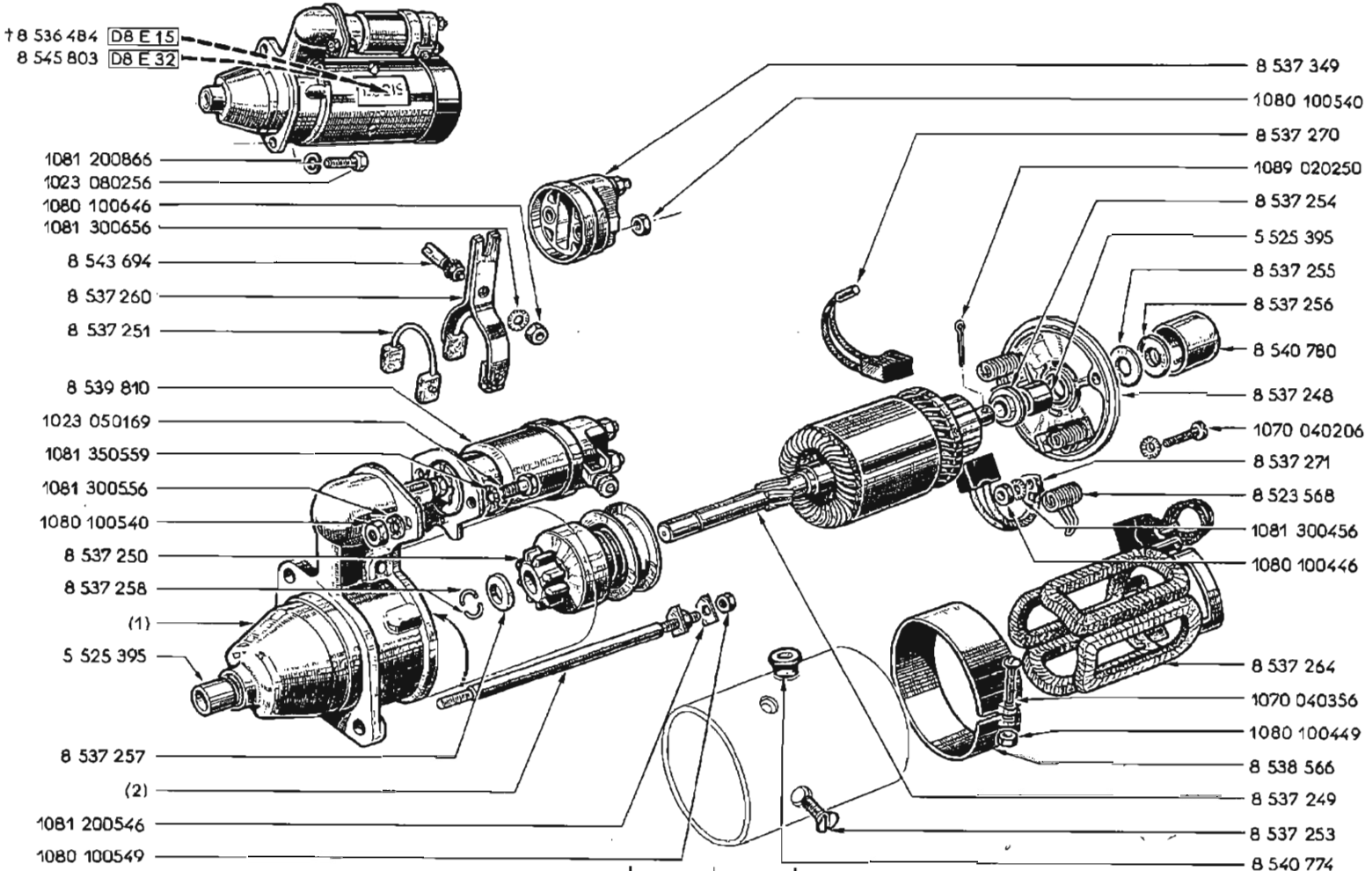

	8536484	8545803
(1)	8537247	8546147
(2)	8544047	8546148

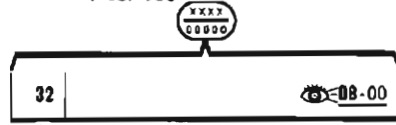
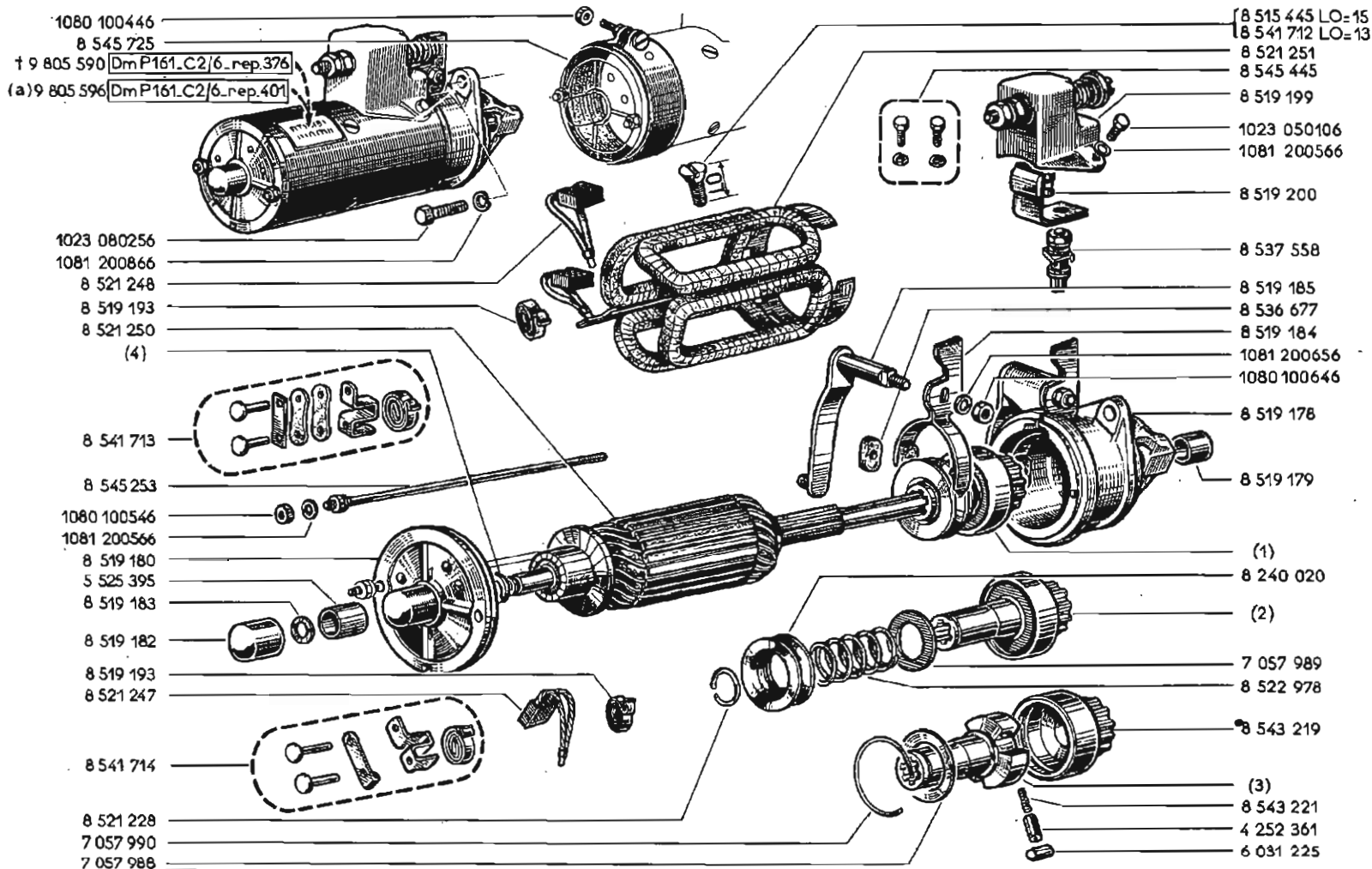

XXXX 00000		!!!	
n°...	→	n°...	⚠
(a) 1 VEH		532892	32

	9805590	9805596
(1)	8518701	8522973
(2)	8543218	8522977
(3)	8543220	8543203

(4)	
8537844	€ = 0,2
8520953	€ = 0,5
8518487	€ = 1
8545255	€ = 1,5

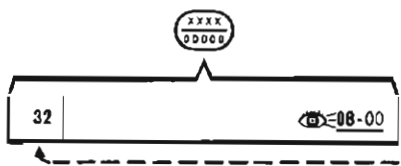
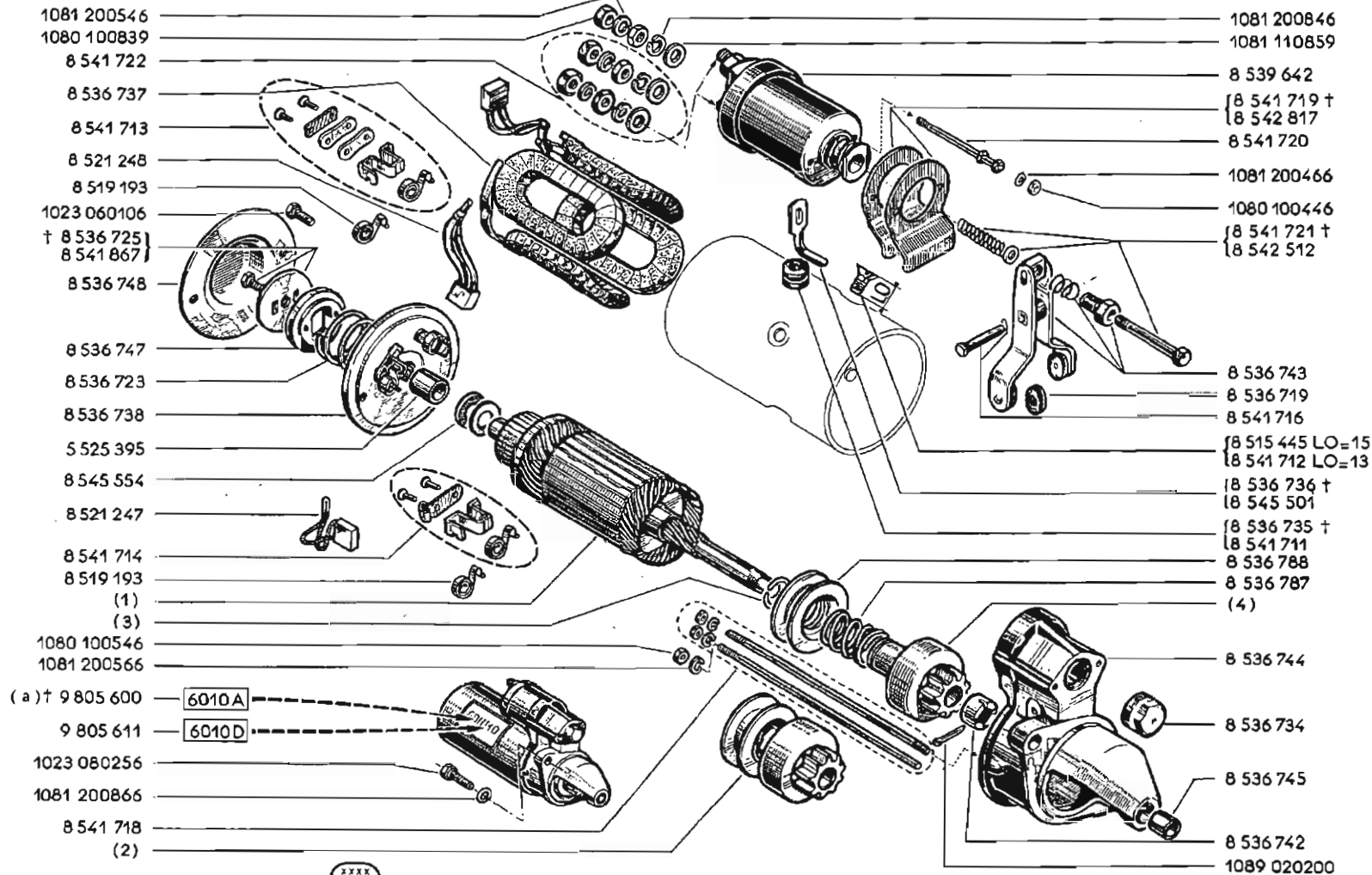

	9805600	9805611
(1)	8536741	8544496
(2)	8536750	8544499
(3)	8536789	8544502
(4)	8546194	8544501

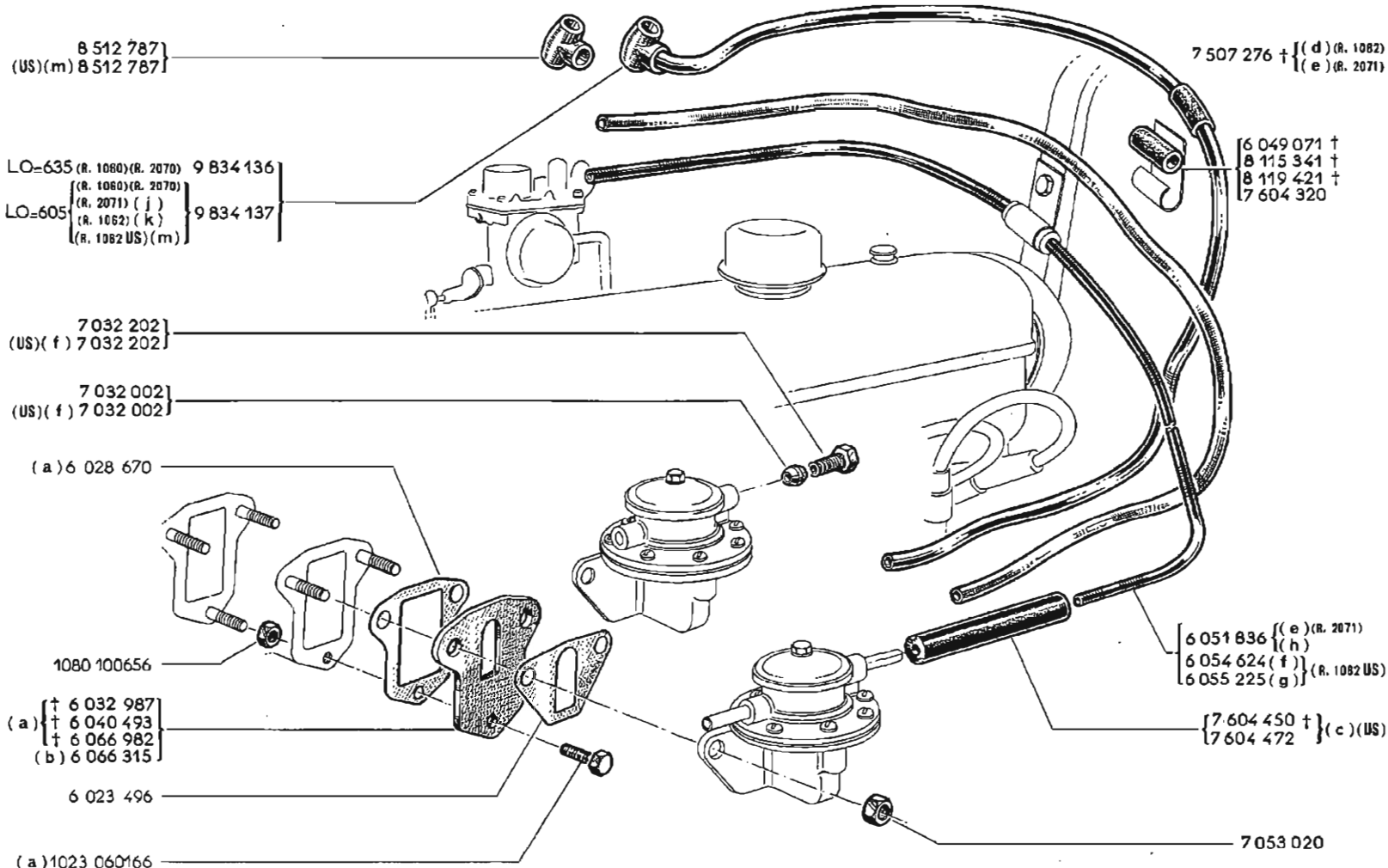

- (a) MOT n° 1 ⇨ MOT n° 864169
- (b) MOT n° 864170 ⇨ MOT n° ...
- (c) VEH n° 324501 ⇨ VEH n° ...
- (d) { VEH n° 224887 ⇨ VEH n° 225000 }
{ VEH n° 225569 ⇨ VEH n° 574399 }

- (e) VEH n° 4241 ⇨ VEH n° ...
- (f) VEH n° 1 ⇨ VEH n° 460887
- (g) VEH n° 460888 ⇨ VEH n° ...
- (h) VEH n° 574400 ⇨ VEH n° ...
- (i) VEH n° 1 ⇨ VEH n° 4240

- (k) { VEH n° 1 ⇨ VEH n° 284886 }
{ VEH n° 225001 ⇨ VEH n° 225568 }
- (m) MOT n° 1 ⇨ MOT n° 324500

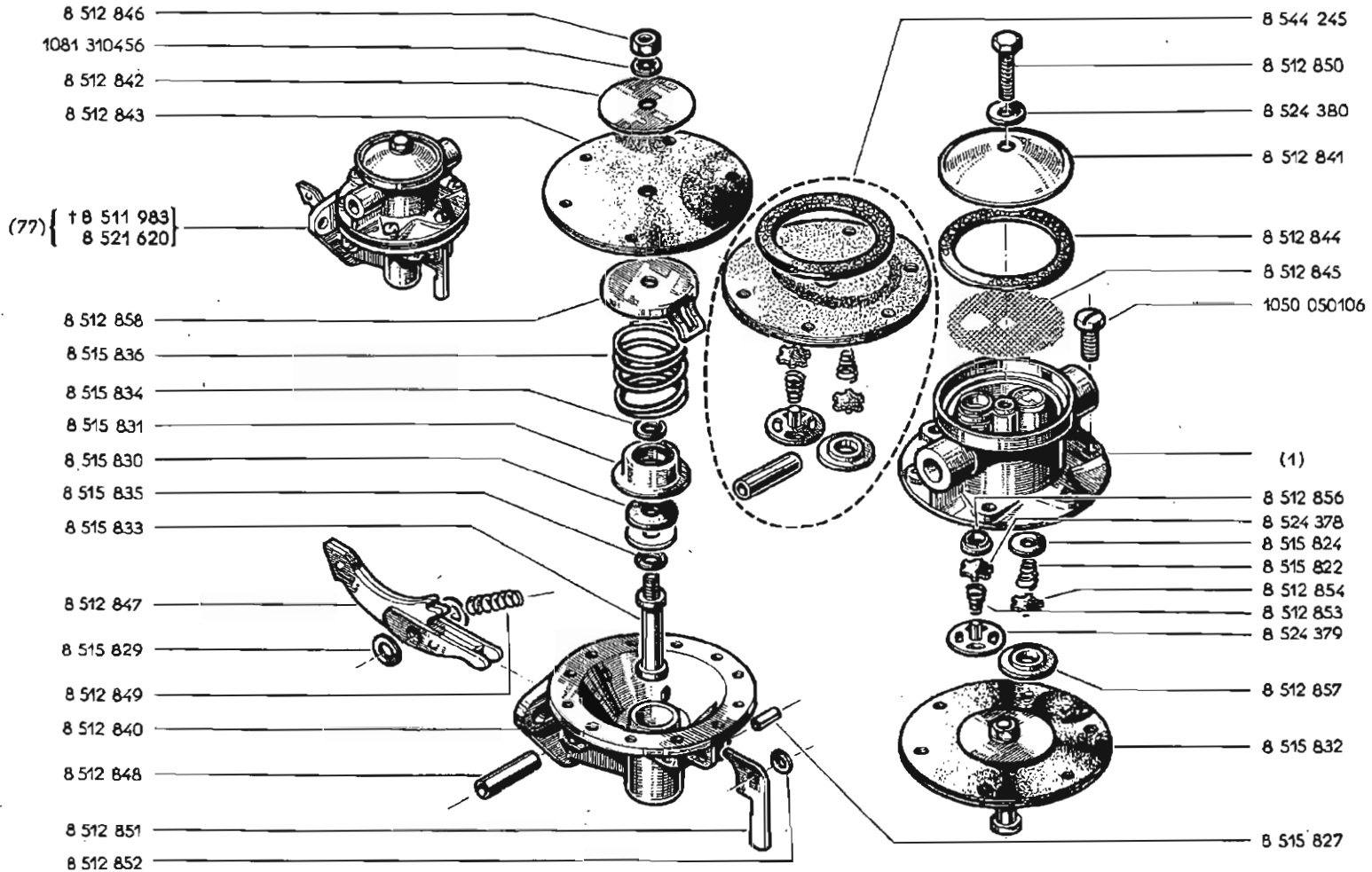

(1)	8511963	8521620
	8515821	8522086

77		7604450 -2-
		7604472 -2-

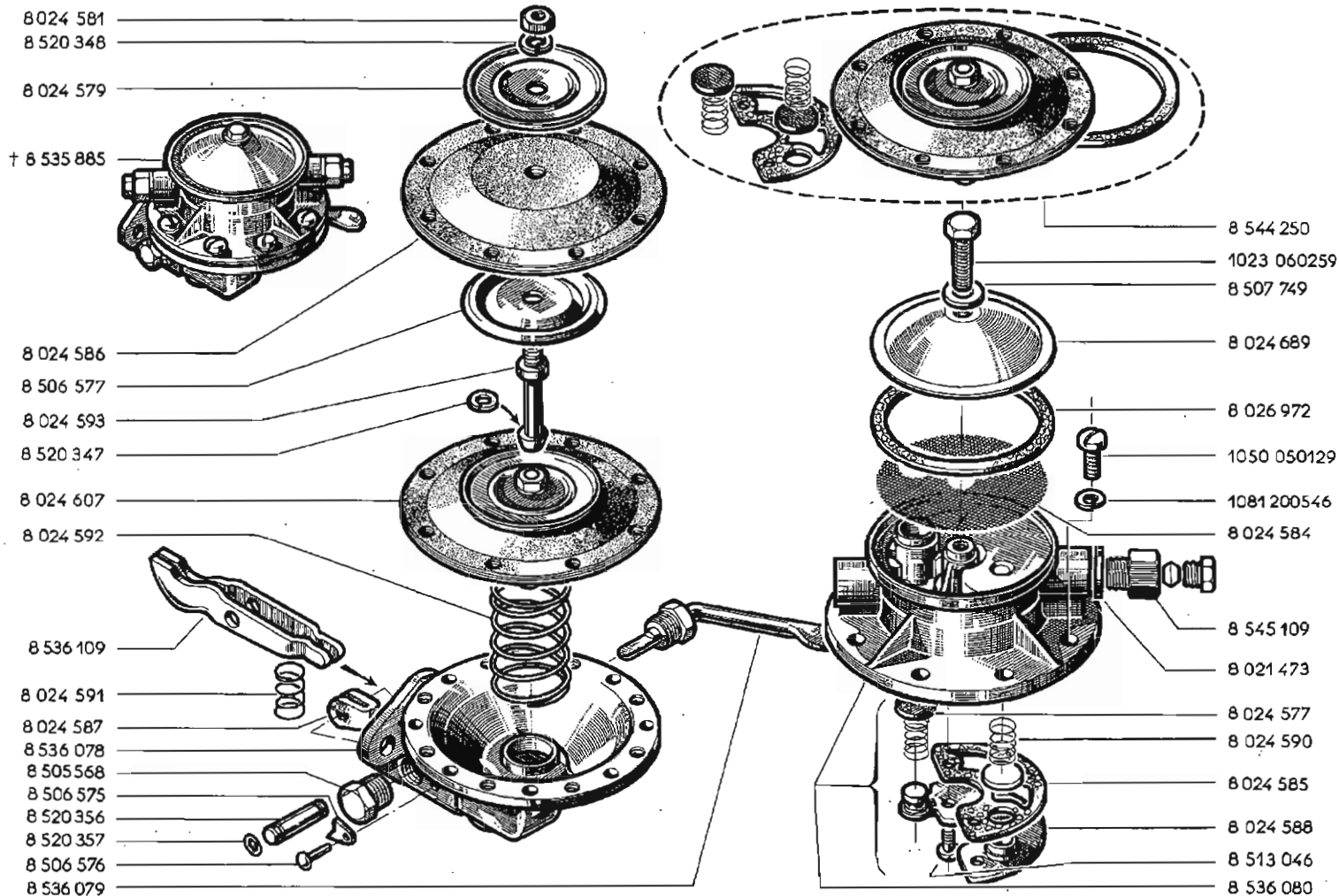

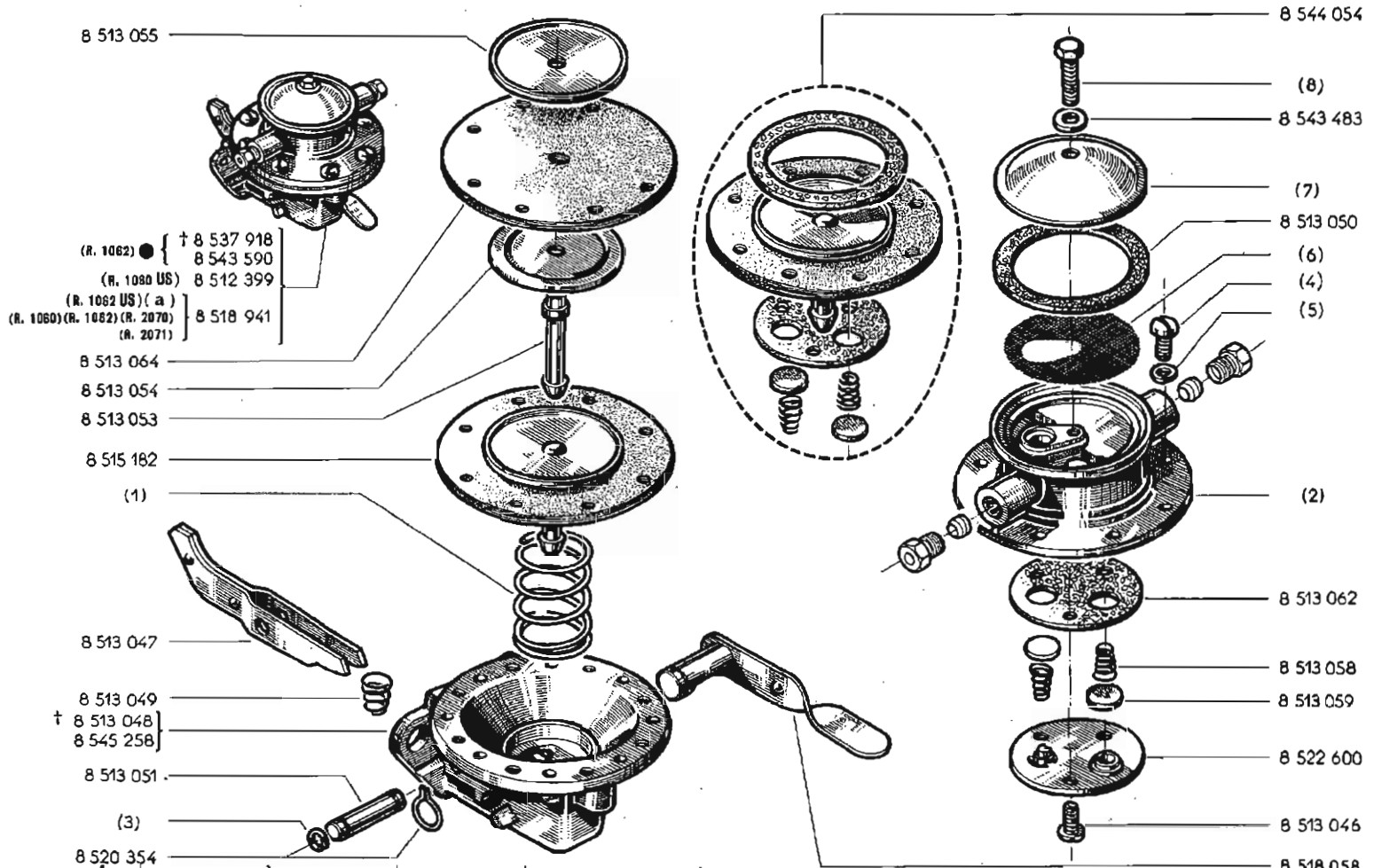

(R. 1062) ● { † 8 537 918
8 543 590
(R. 1080 US) 8 512 399
(R. 1062 US) (a)
(R. 1060) (R. 1082) (R. 2070) } 8 518 941
(R. 2071)

	8537918	8512399	8518941	8543590
(1)	8544327	8538947	8538947	8538947
(2)	8519224	8513065	8519224	8544051 † } (c) 8546202 8027240
(3)	8520357	8520357	8520357	
(4)	8024595 †	8024595 †	8024595 †	
	1050 050129	1050 050129	1050 050129	1050 040100

	8537918	8512399	8518941	8543590
(5)	1081 200546	1081 200546	1081 200546	1081 200446
(6)	8513063	8513063	8513063	8544052 } (b) 8546203 } (d) 8544053
(7)	8513060	8513060	8513060	8544053
(8)	8513061	8513061	8513061	8544119

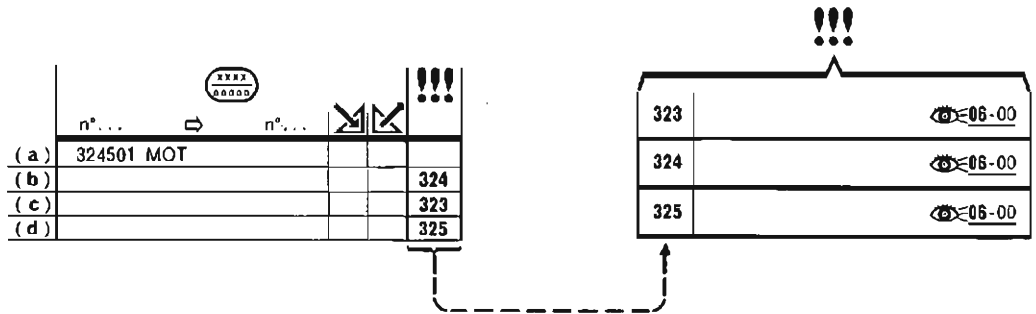

(a) † 8 523 217

8 543 133

8 523 766

8 543 999

8 544 000

8 523 772

8 523 753

8 523 771

8 544 002

8 544 001

8 543 132

8 543 995

8 523 759

8 543 996

8 523 761

8 523 762

8 523 775

8 523 754

8 543 998

8 523 756

8 523 756

(a) ⊕ 10-08

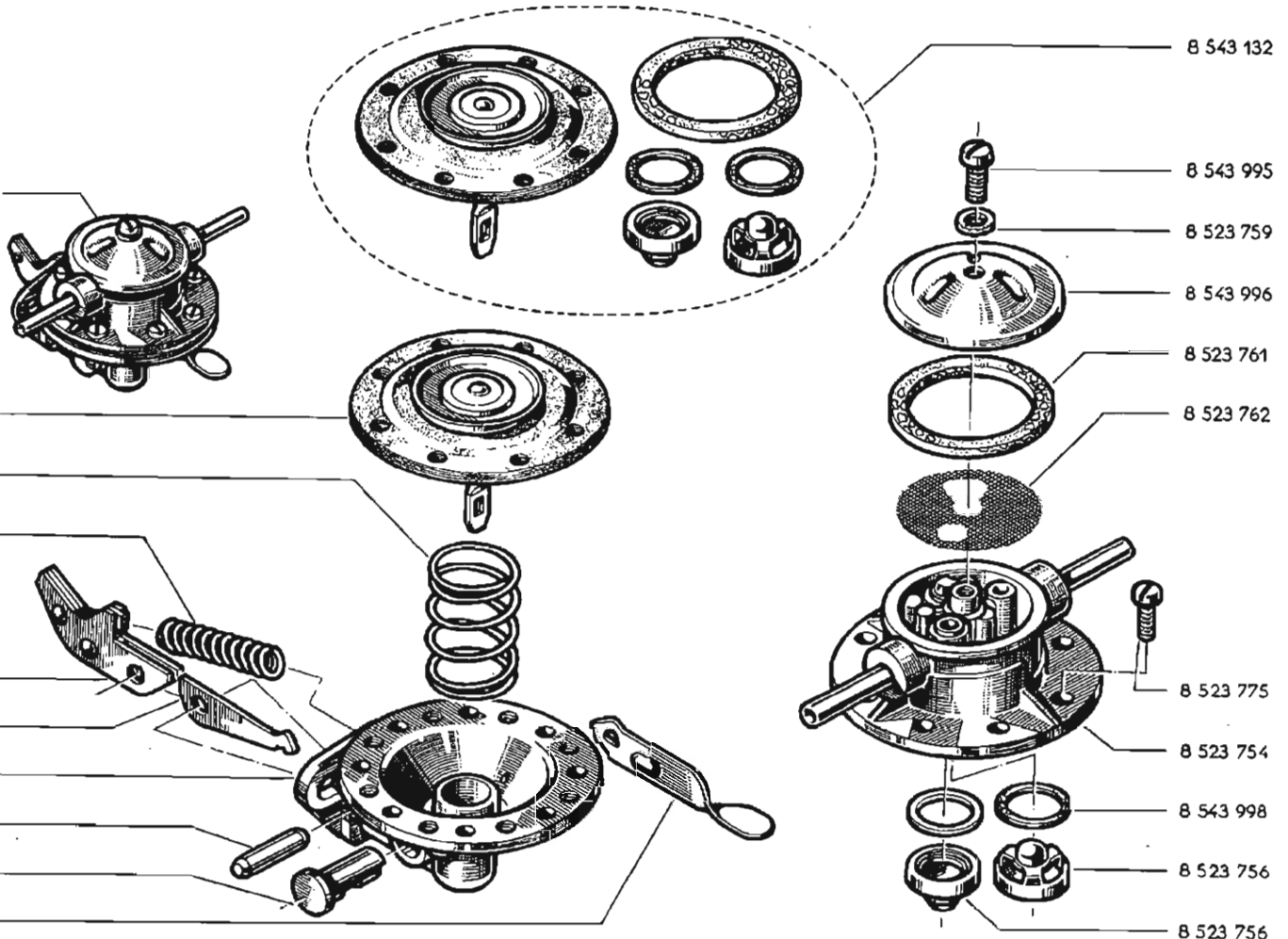

8 544 270

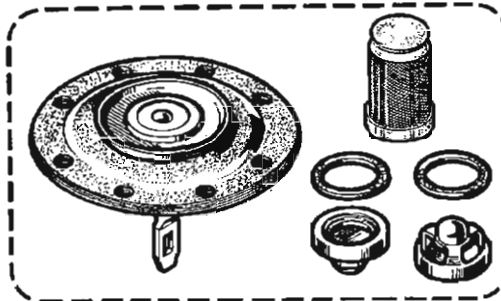
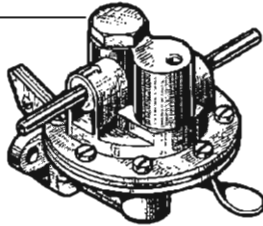

8 543 132

8 543 133

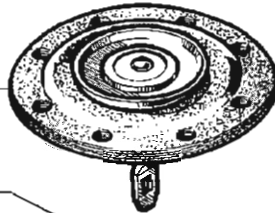

8 544 341



8 544 263



8 544 342

8 523 766

8 543 999

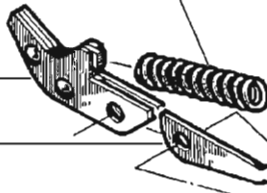

8 523 775

8 544 000

8 523 772

8 544 343

8 523 771

8 544 002

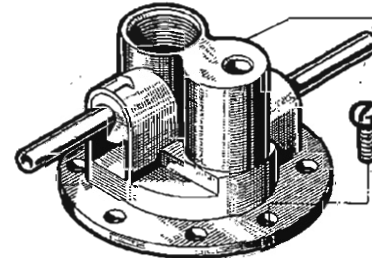
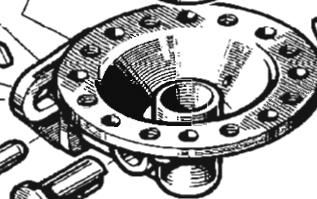

8 543 998

8 523 756

8 523 756

8 544 001

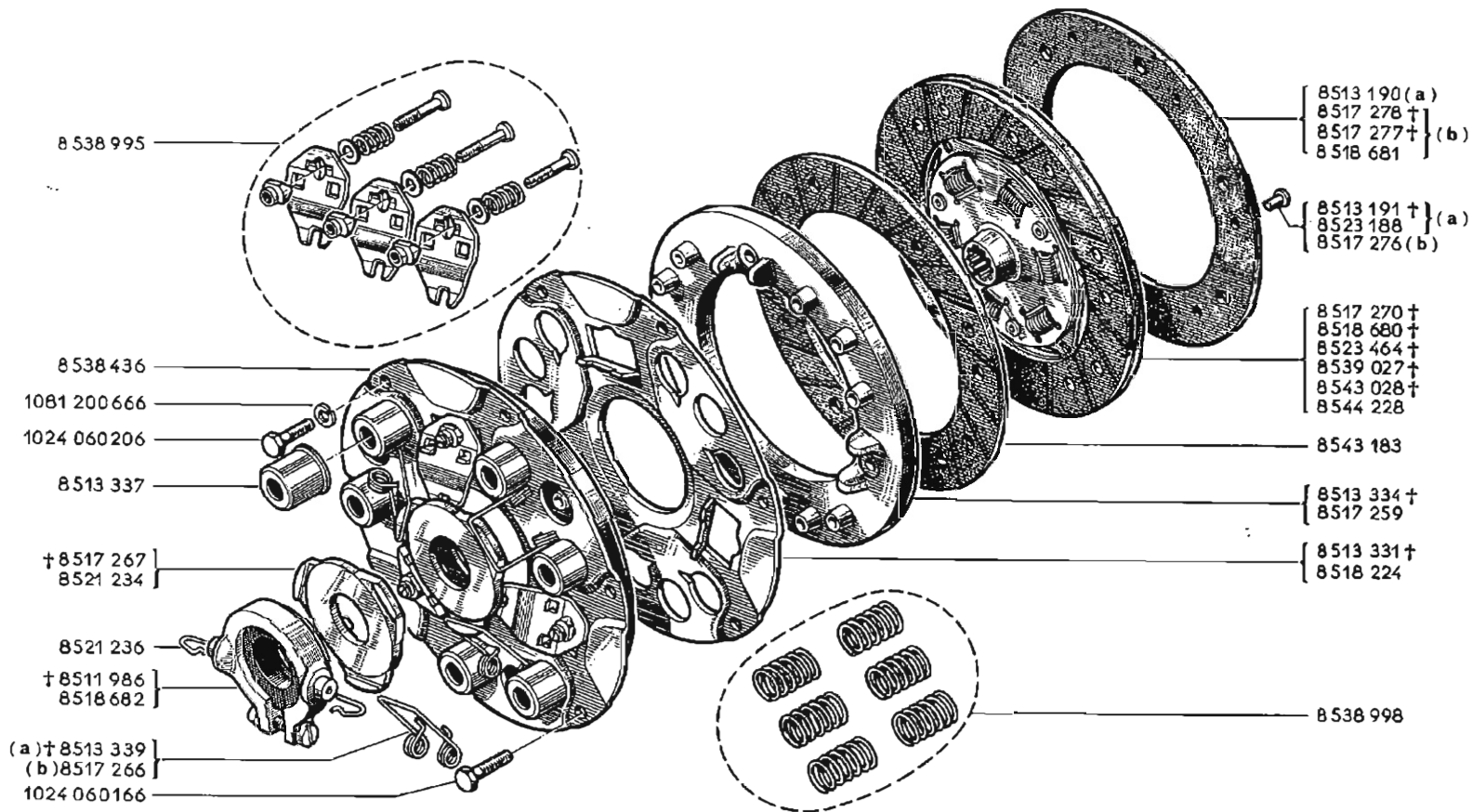

(a) MOT n° 1 ⇔ MOT n° 152579
 (b) MOT n° 152580 ⇔ MOT n° ...

- † 8 517 270
- † 8 518 680
- (a) † 8 523 464
- † 8 539 027
- † 8 543 028
- 8 544 228

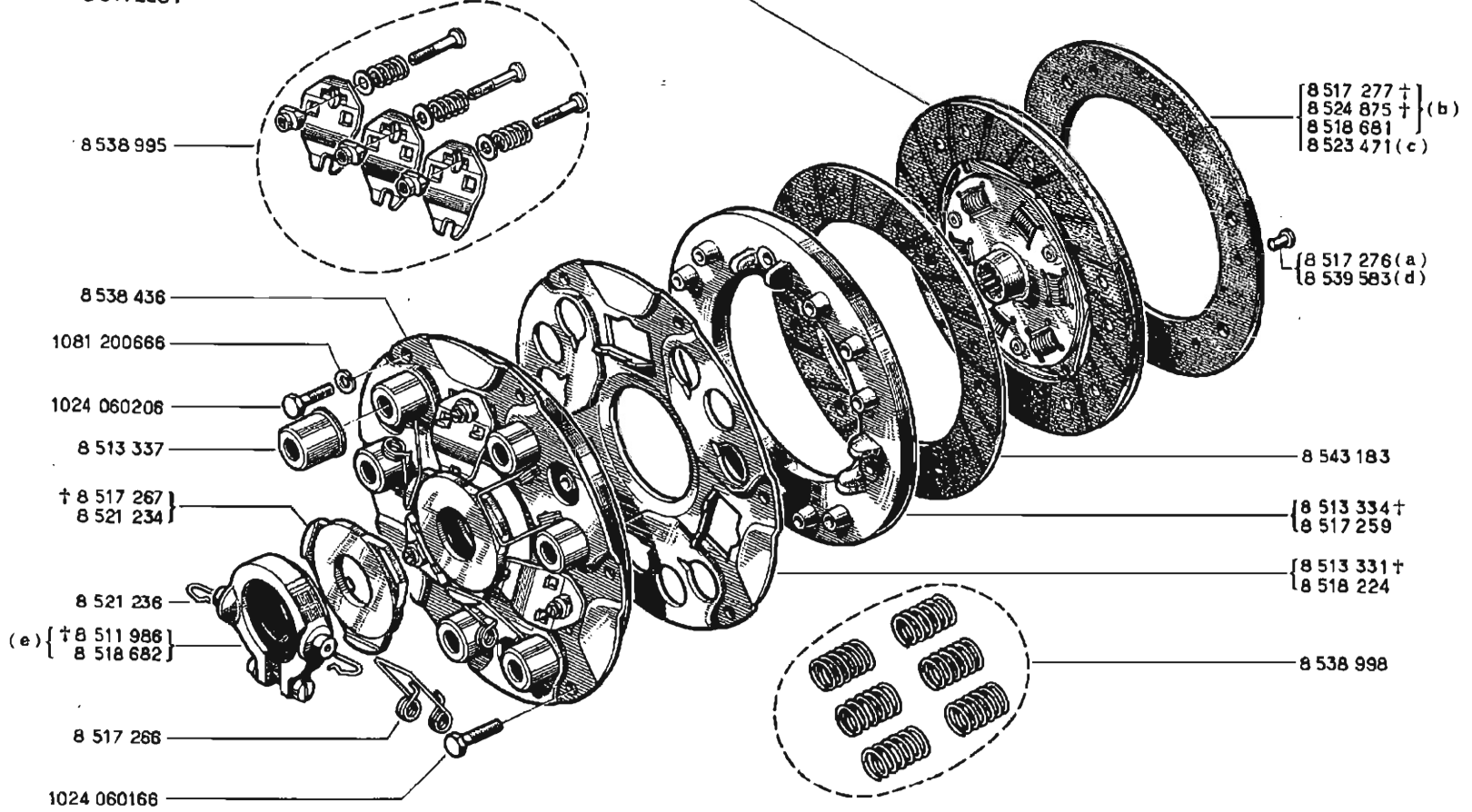

8 538 995

8 538 436

1081 200666

1024 060206

8 513 337

† 8 517 267
8 521 234

8 521 236

(e) † 8 511 986
8 518 682

8 517 266

1024 060166

{ 8 517 277 †
8 524 875 † } (b)
8 518 681
8 523 471 (c)

{ 8 517 276 (a)
8 539 583 (d)

8 543 183

{ 8 513 334 †
8 517 259

{ 8 513 331 †
8 518 224

8 538 998

XXXX
0000

54	08-00
55	08-00

XXXX
0000

	n°...	⇒	n°...	⚡	⚡	!!!
(a)	1 MOT		685476			
(b)	1 MOT		305620	55		
(c)	341243 MOT		...	54		
(d)	685477 MOT		...			
(e)						89

!!!

99	8521234 - y -
----	---------------



A P.R. 685

A P.R. 685

- (a) 8 539 581
- (b) 8 536 341
- 8 536 342
- (c) 8 536 342
- (d) 8 541 219
- 8 536 426
- † 8 536 425
- 8 542 895
- † 8 536 422
- † 8 542 130
- 8 542 895
- (a) † 8 536 418
- (b) 8 537 355
- † 8 536 419
- † 8 542 129
- 8 542 893
- 8 536 341
- (c) † 8 536 341
- (d) † 8 541 218
- 8 542 894
- (a) 8 539 582
- (b) 8 536 342

- 8 537 495 †
- 8 542 012
- 8 536 173 (251)
- 8 536 173 99 ER

- 8 536 447
- 8 536 421
- 8 540 859
- 8 541 391
- 1070 030126
- 1081 310356
- 1081 100359
- 8 540 858
- 8 540 856
- 8 541 387
- 8 540 855
- 8 540 857
- 8 536 417
- 8 541 393

- 8 536 424
- 8 540 869 (f)
- 8 540 892 (e)
- 8 536 424
- 8 536 423
- 8 541 395
- 8 541 394
- 8 541 396
- 1081 310756
- 8 541 392
- 8 540 860

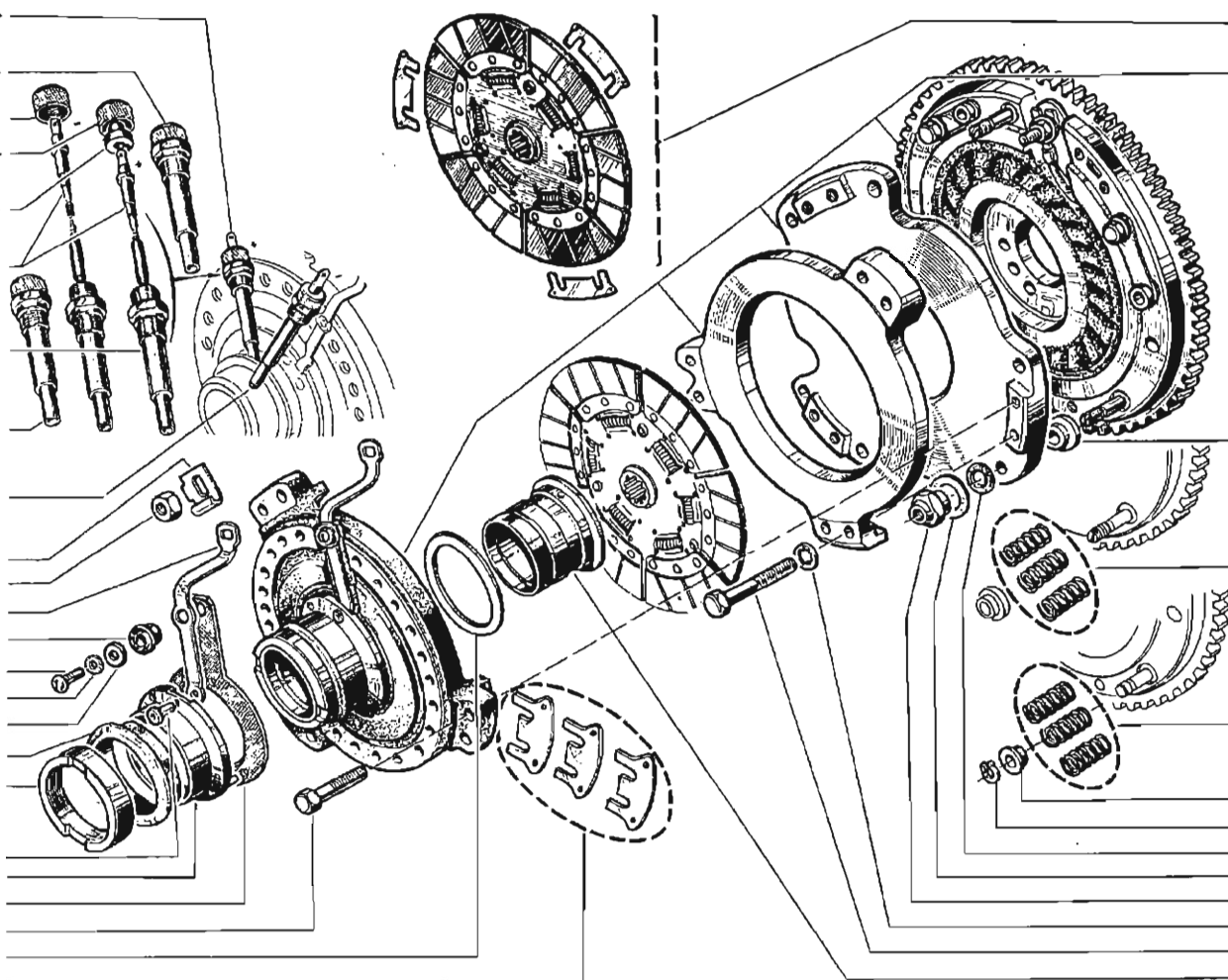

(1)

(1)	
8536448 †	} E=0,2
8540881	
8544818	E=0,1

- (a) VEH n° 1 ⇔ VEH n° 509349
- (b) VEH n° 509350 ⇔ VEH n° ...
- (c) MOT n° 1 ⇔ MOT n° 786099
- (d) MOT n° 786100 ⇔ MOT n° ...
- (e) MEC n° 1 ⇔ MEC n° 265-56
- (f) MEC n° 266-56 ⇔ MEC n° ...

30.07

A P.R. 685

● † 8 536 341

● 8 536 342
8 541 219

8 536 426

† 8 536 425
8 542 895

† 8 536 422

† 8 542 130

8 542 895

8 537 355

† 8 541 218

8 542 894

† 8 536 419

† 8 542 129

8 542 893

8 536 342

8 542 117

8 542 115

8 542 118

8 542 116

1081 300456

1024 040166

8 541 387

1070 030126

1081 310356

1081 100359

8 541 391

FERLEC (R. 1062) MOT n° 796897 ⇔ MOT n° ...

30.07

A P.R. 685

† 8 537 495

† 8 541 211

† 8 543 790

† 8 542 069

8 542 069 99 ER

8 536 424

8 540 869

1081 300656

1080 100656

8 541 395

8 541 394

8 541 396

1081 310756

8 541 392

(1)

8 536 417

8 540 859

8 536 447

8 536 421

(1)

8536448 †	} E=0,2
8540861	
8544818	E=0,1

(a) 8 540 862

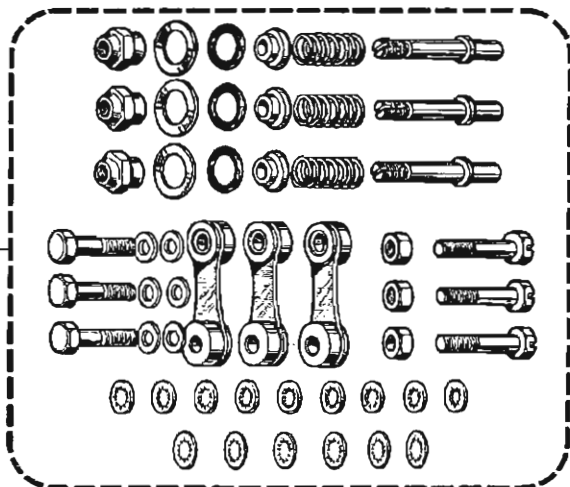

8 540 867 (c)

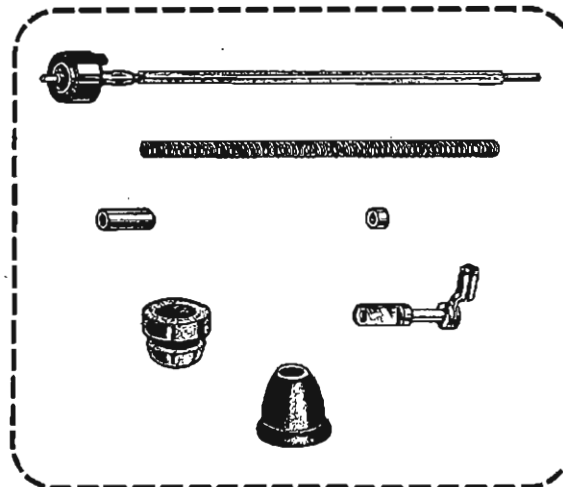

(b) 8 540 863

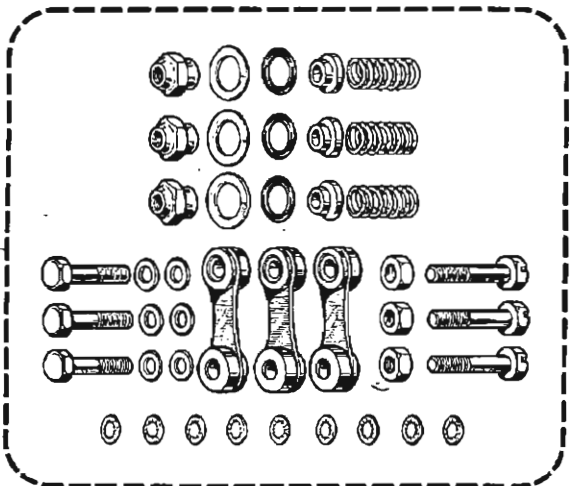



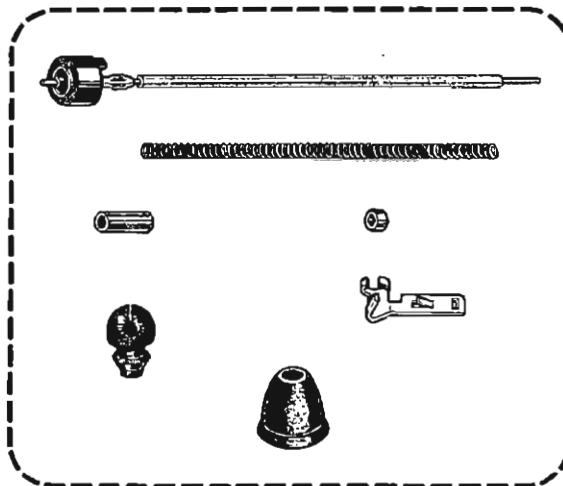

8 541 096 (d)

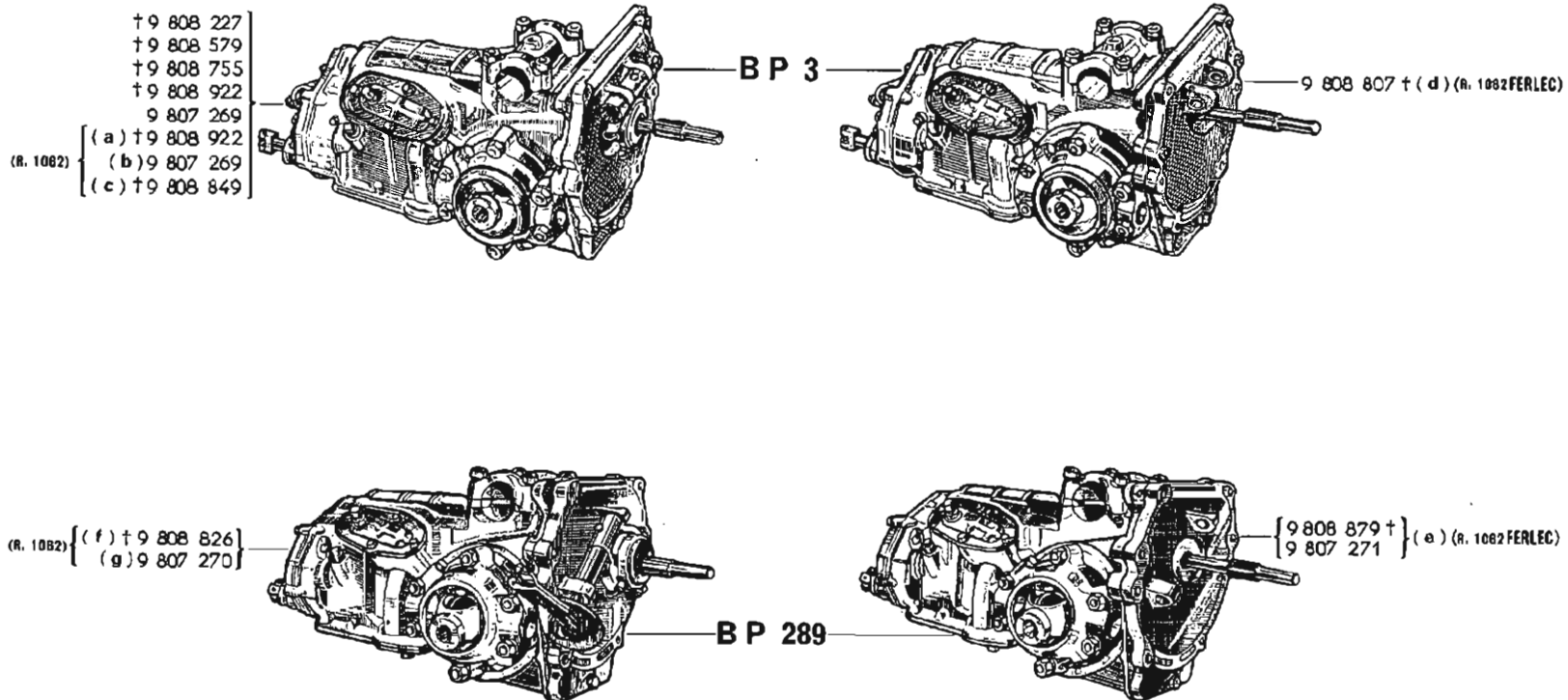



(a) MEC n° 1 ⇨ MEC n° 265-56
 (b) MEC n° 266-56 ⇨ MEC n° ...
 (c) VEH n° 1 ⇨ VEH n° 742155
 (d) VEH n° 742156 ⇨ VEH n° ...



XXXX
00000

25	 08-00
26	 08-00
30	 08-00
31	 08-00
87	 08-00

XXXX
00000

	n°...	n°...			
(a)	1 VEH	450603	26	25	4
(b)	1 VEH	450603			
(c)	450604 VEH	500024	25	26	
			31	30	
(d)	1 VEH	500024	31	30	
(e)	500025 VEH	841460	87		
(f)	450604 VEH	841460	25	26	
			87		
(g)	450604 VEH	841460	87		

!!!

4		7059451 -3-
---	---	-------------



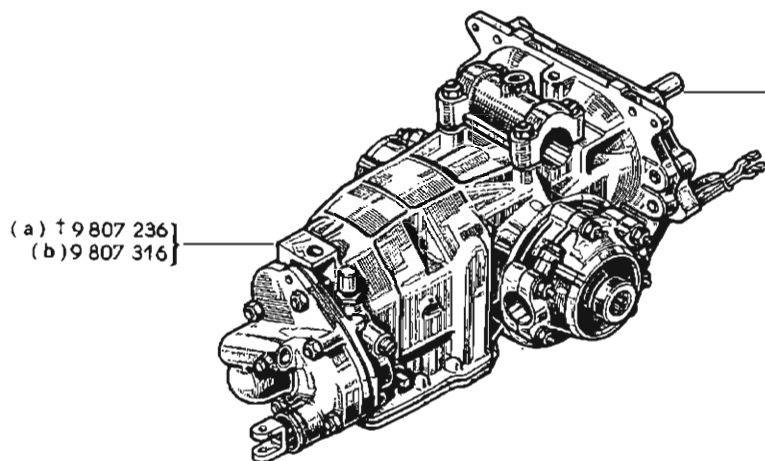

{ BP 314-11 }
{ BP 314-27 }

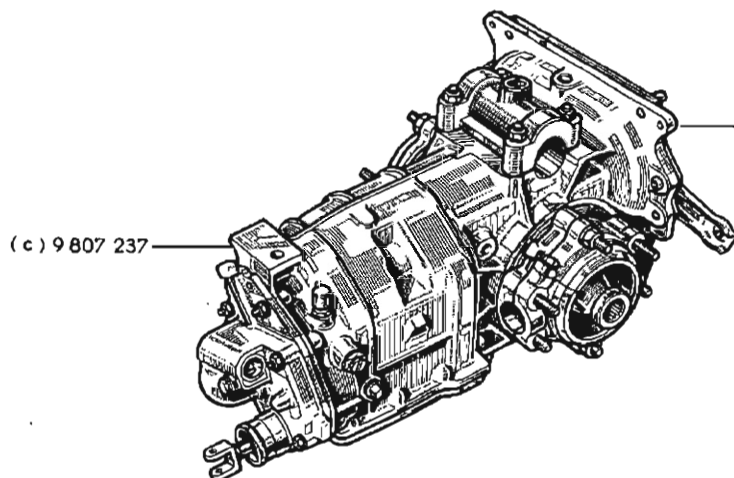
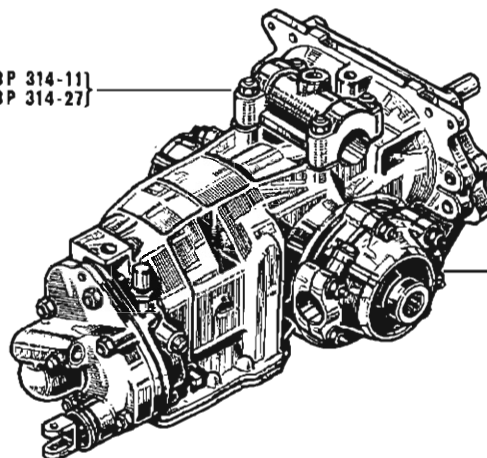

{ BP 314-31 }
{ BP 314-35 }

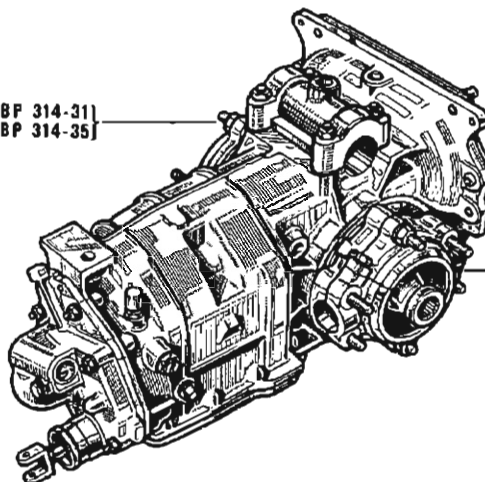

XXXX
00000

87	08-00
88	08-00

XXXX
00000

	n°...	→	n°...	✓	✓	!!!
(a)	841461 VEH		879969			87
(b)	841461 VEH		916908			88
(c)	916909 MOT		...			88



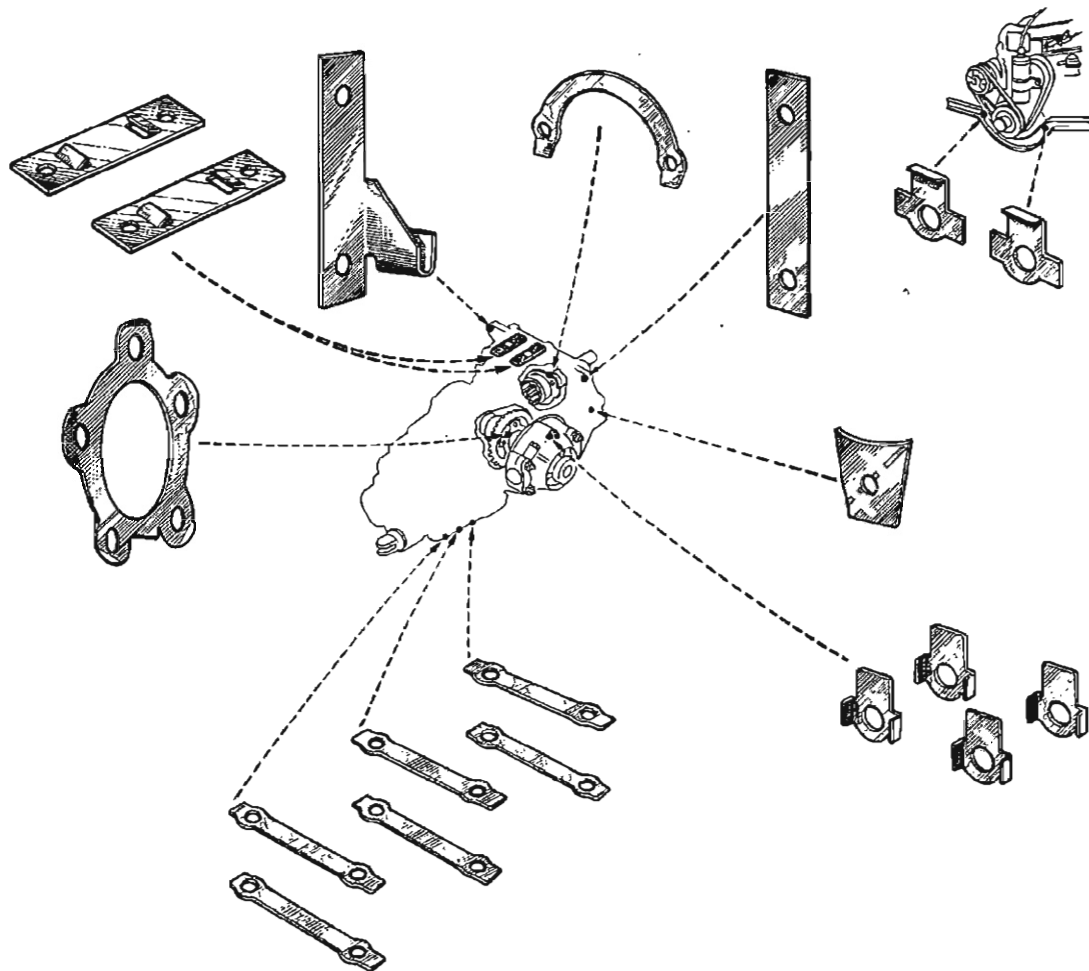

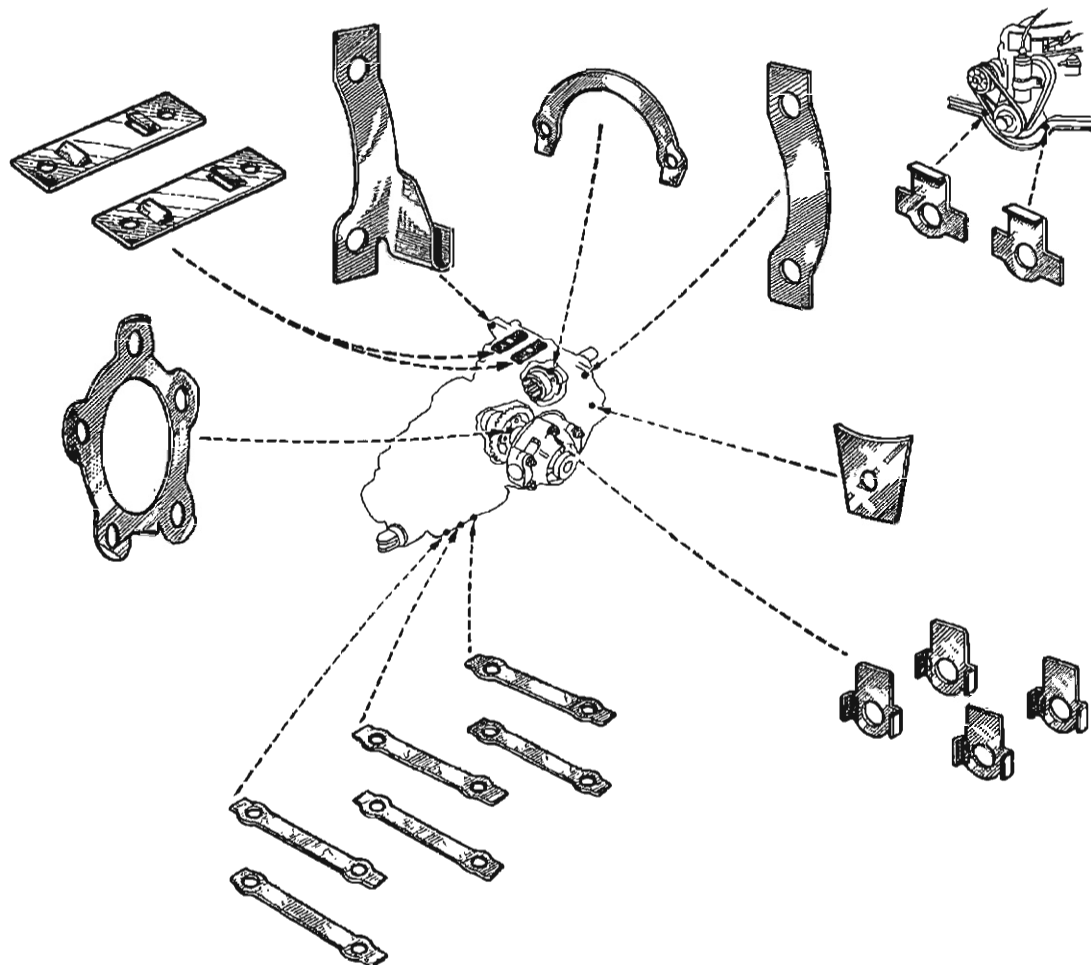

31.11

B P.R. 685

BP 3 - (R. 1060 - R. 2070)

31.11

B P.R. 685

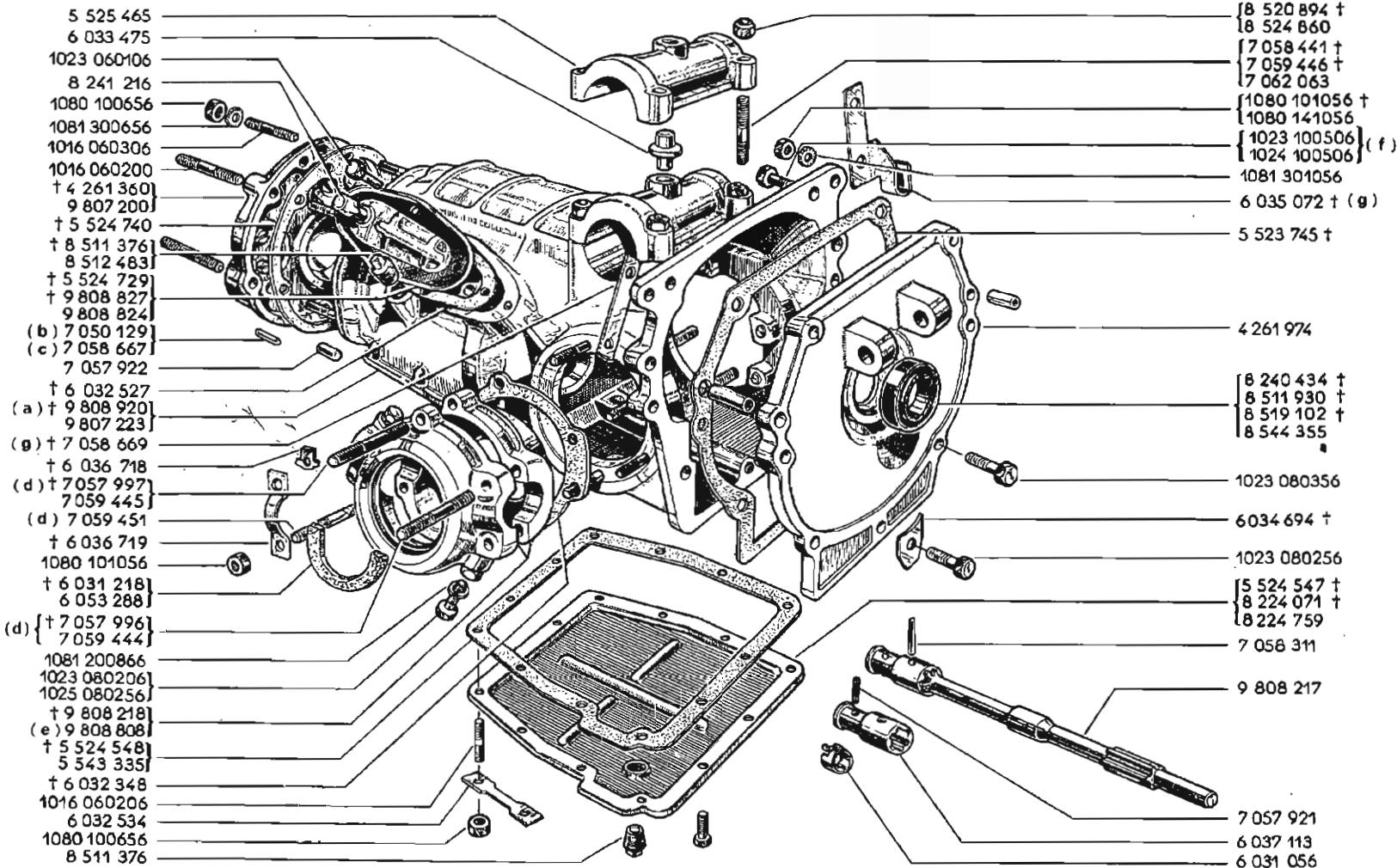

- 5 525 465
- 6 033 475
- 1023 060106
- 8 241 216
- 1080 100656
- 1081 300656
- 1016 060306
- 1016 060200
- † 4 261 360
- 9 807 200
- † 5 524 740
- † 8 511 376
- 8 512 483
- † 5 524 729
- † 9 808 827
- 9 808 824
- (b) 7 050 129
- (c) 7 058 667
- 7 057 922
- † 6 032 527
- (a) † 9 808 920
- 9 807 223
- (g) † 7 058 669
- † 6 036 718
- (d) † 7 057 997
- 7 059 445
- (d) 7 059 451
- † 6 036 719
- 1080 101056
- † 6 031 218
- 6 053 288
- (d) † 7 057 996
- 7 059 444
- 1081 200866
- 1023 080206
- 1025 080256
- † 9 808 218
- (e) 9 808 808
- † 5 524 548
- 5 543 335
- † 6 032 348
- 1016 060206
- 6 032 534
- 1080 100656
- 8 511 376

- { 8 520 894 †
- 8 524 860
- { 7 058 441 †
- 7 059 446 †
- 7 062 063
- { 1080 101056 †
- 1080 141056
- { 1023 100506 } (f)
- { 1024 100506 } (f)
- 1081 301056
- 6 035 072 † (g)
- 5 523 745 †
- 4 261 974
- { 8 240 434 †
- 8 511 930 †
- 8 519 102 †
- 8 544 355
- 1023 080356
- 6034 694 †
- 1023 080256
- { 5 524 547 †
- 8 224 071 †
- 8 224 759
- 7 058 311
- 9 808 217
- 7 057 921
- 6 037 113
- 6 031 056

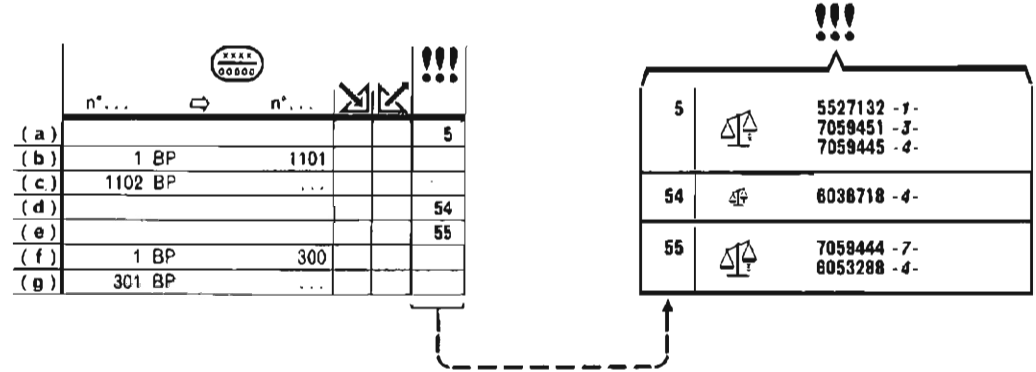

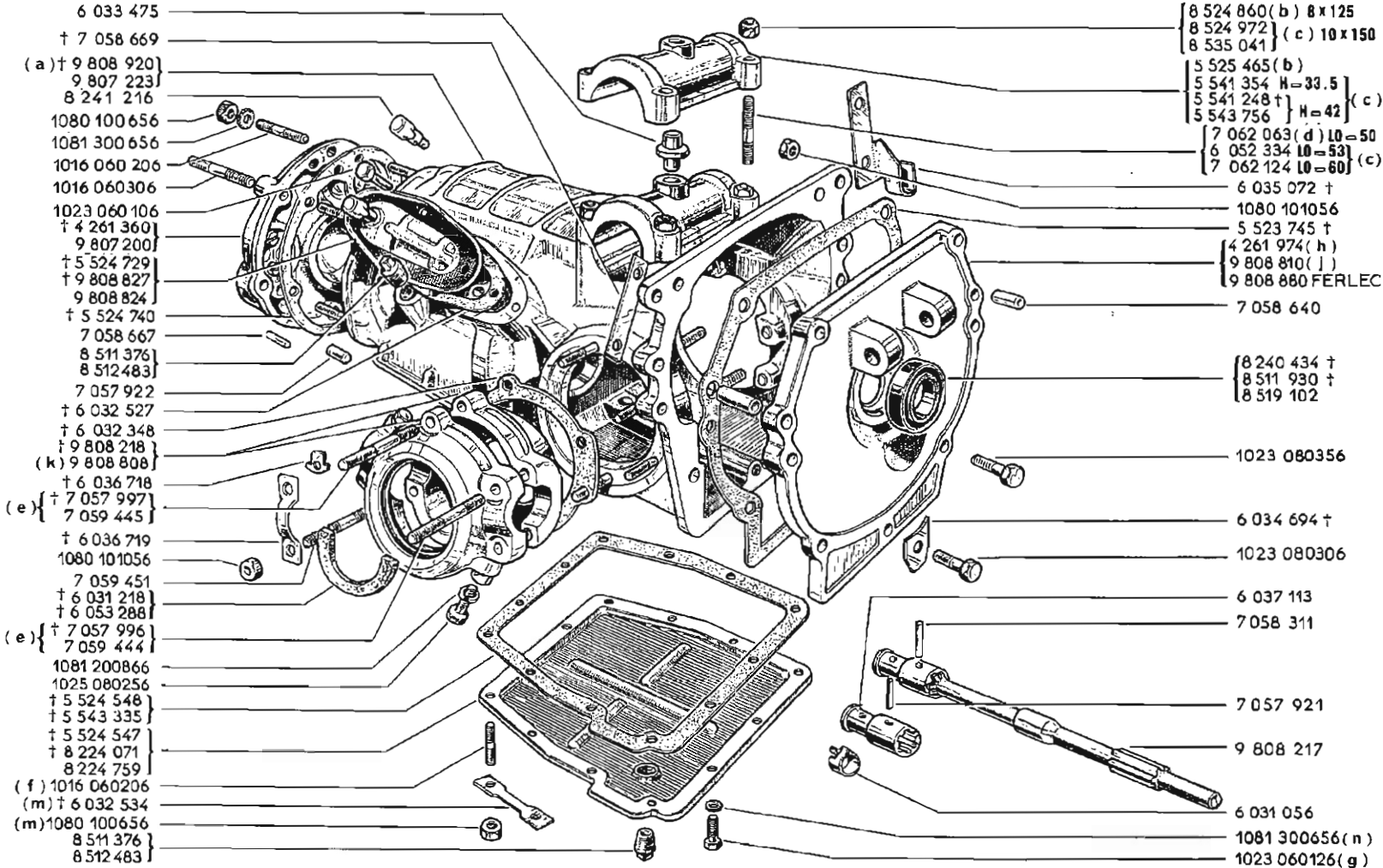

25		
28		
58		

	n°...	n°...	
(a)			5
(b)	1 BP	559990	
(c)	559991 BP	...	
(d)	1 BP	559990	52
(e)			54
(f)	1 BP	576675	56
(g)	576676 BP	...	56
(h)	1 VEH	450603	28 25
(j)	450604 VEH	...	25 28
(k)			55
(m)	1 BP	576675	
(n)	576676 BP	...	

5		5527132 -1- 7059451 -3- 7059445 -4-
52		8524860 -4-
54		6036718 -4-
55		7059444 -7- 6053288 -4-



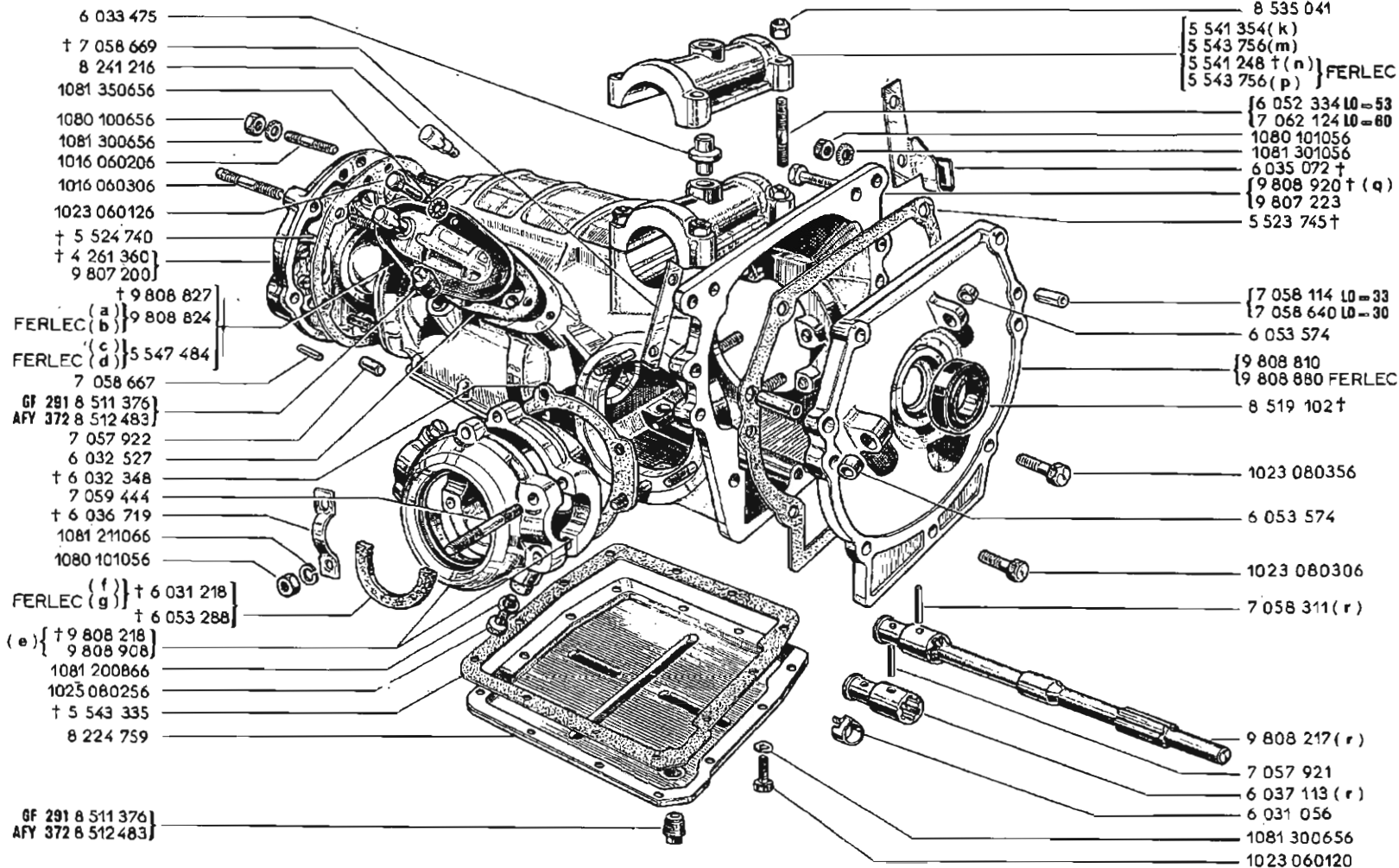

XXXX
00000

87		08-00
----	--	-------

	XXXX 00000	n°...	n°...	!!!
(a)		1 BP	266840	
(b)		1 BP	18288	
(c)		266841 BP	...	
(d)		18289 BP	...	
(e)				062
(f)		1 BP	58625	
(g)		1 BP	2908	
(h)		58625 BP	...	87
(j)		2909 BP	...	87
(k)		1 BP	31566	
(m)		31567 BP	...	
(n)		1 BP	1657	
(p)		1658 BP	...	
(q)				081
(r)				87

!!!

61		7059445 -4-
62		7059444 -4- 6053288 -4-



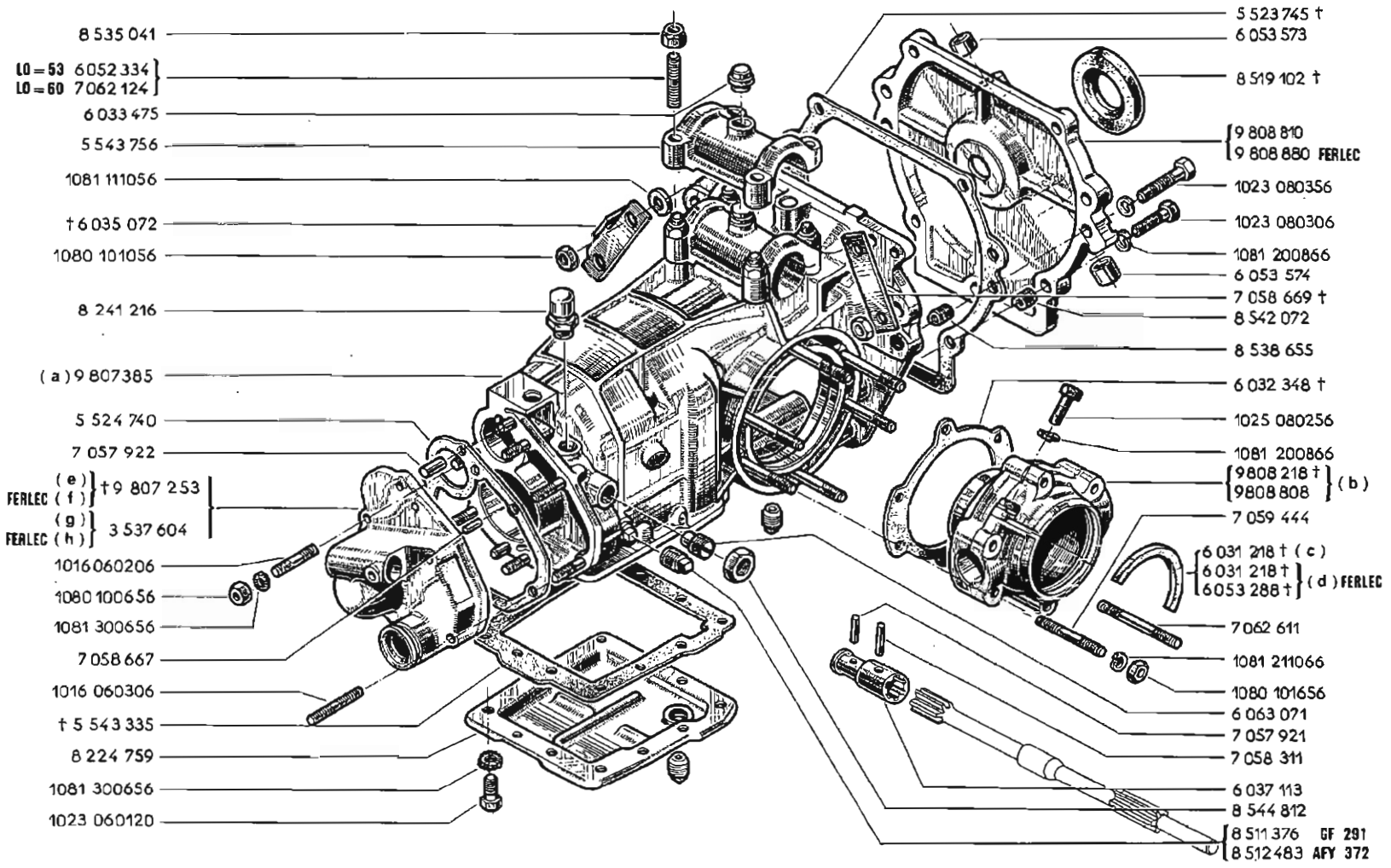

XXXX
00000

87

08-00

	n°...	n°...	!!!
(a)			61
(b)			62
(c)	1 BP	58625	
(d)	1 BP	2908	
(e)	1 BP	23279	87
(f)	1 BP	529	87
(g)	23280 BP	...	
(h)	530 BP	...	

!!!

61	⚖	7059445 -4-
62	⚖	7059444 -4- 8053288 -4-



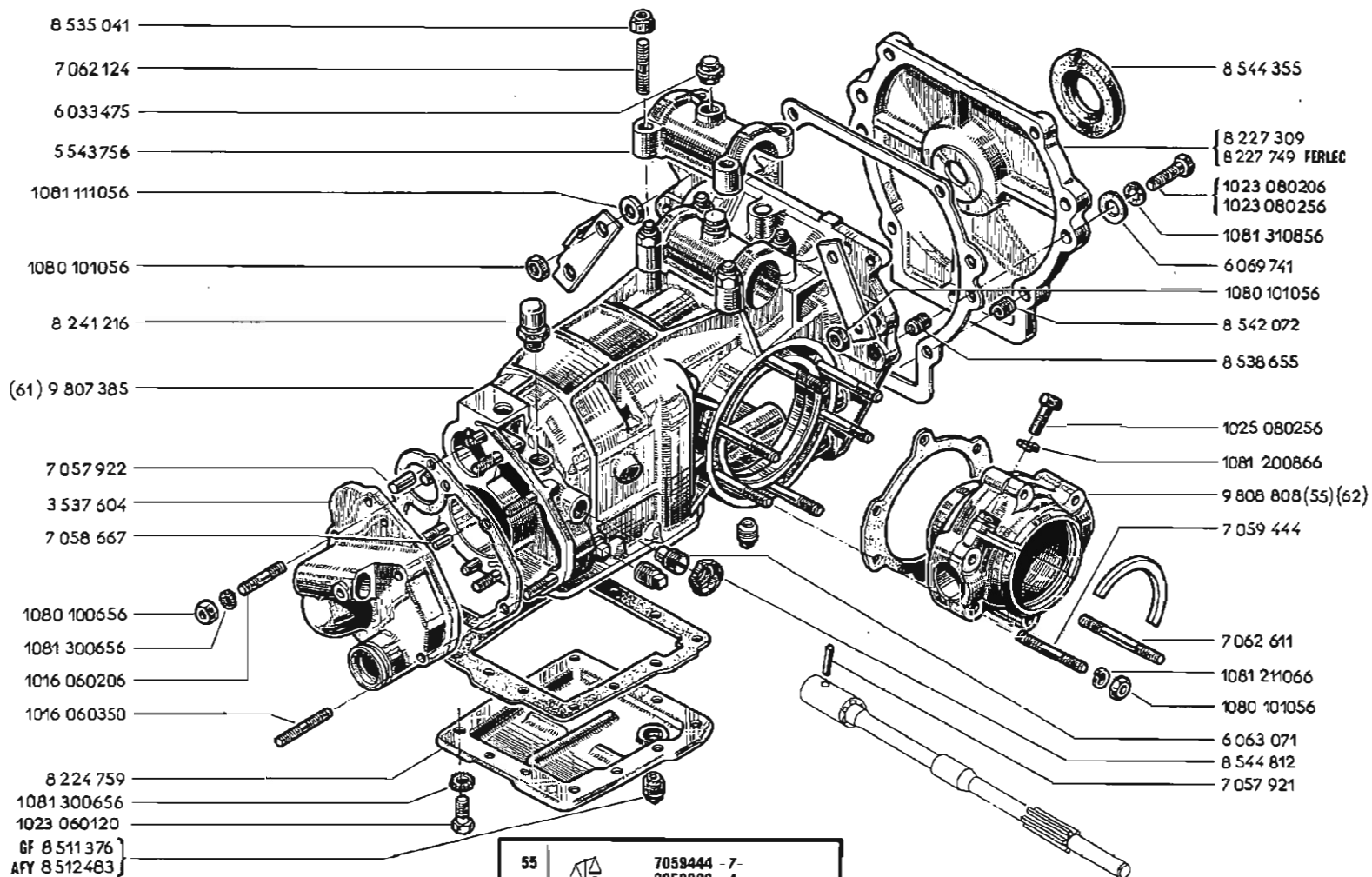

55		7059444 - 7- 8053288 - 4-
61		7059445 - 4-
82		7059444 - 4- 8053288 - 4-

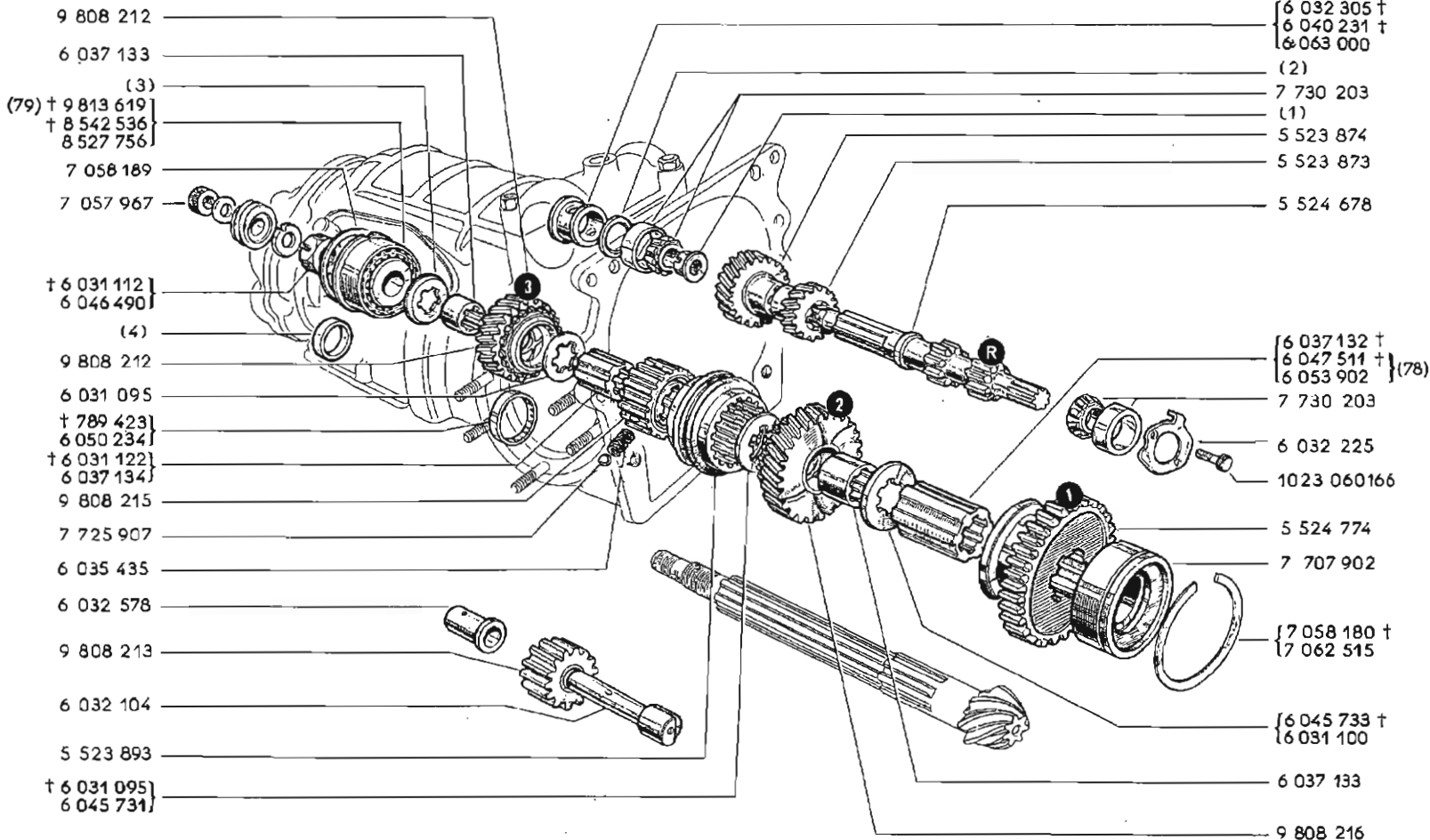

78	6047509 -1-
79	06-00

(1)	(2)	(3)	(4)
6032560D1=10	7057944 E=0,95	6031109 E=8,7	6036064 E=7,5
1080 1712560D1=12	7057945 E=0,50	6031108 E=8,6	6036065 E=7,4
	7057946 E=0,20	6031107 E=8,5	6036066 E=7,3
	7057947 E=0,10	6031106 E=8,4	6035286 † E=6,15
		6031105 E=8,3	6035287 † E=6,2
		6033399 E=8,2	6035288 † E=6,25
			6035289 † E=6,3
			6035290 † E=6,35
			6035291 † E=6,40
			6035292 † E=6,45
			6035293 † E=6,5
			6035294 † E=6,55
			6035295 † E=6,6
			6035296 † E=6,65
			6035297 † E=6,7
			6035298 † E=6,75
			6035299 † E=6,8
			6035300 † E=6,85

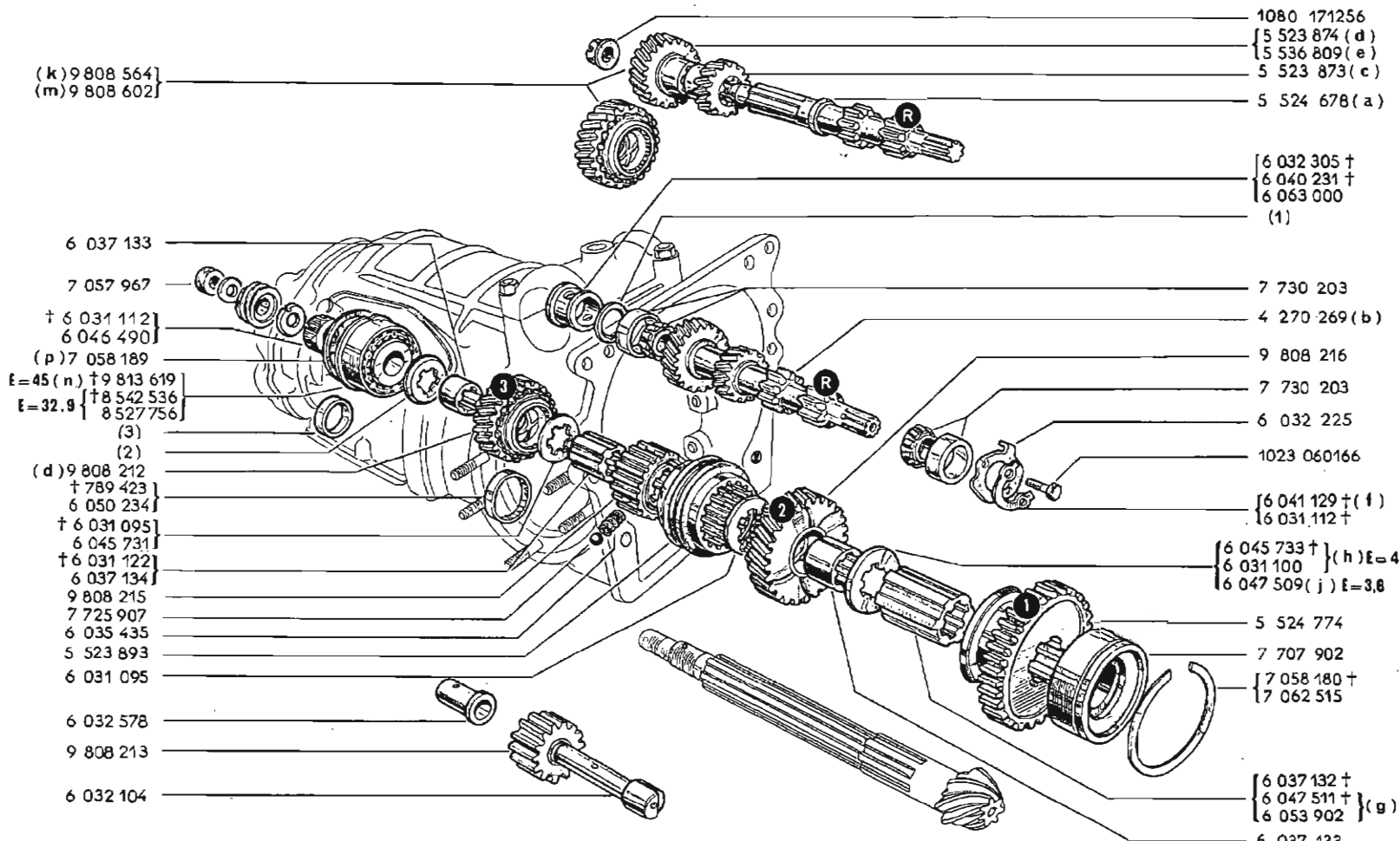

(1)		(2)		(3)		
7057944 E=0,95	6031109 E=8,7	6033400 E=8,1	6036064 E=7,5	6035285 † E=6,15	6035292 † E=6,45	6035298 † E=6,75
7057945 E=0,50	6031108 E=8,6	6033401 E=8	6036065 E=7,4	6035287 † E=6,2	6035293 † E=6,5	6035299 † E=6,8
7057946 E=0,20	6031107 E=8,5	6033402 E=7,9	6036066 E=7,3	6035288 † E=6,25	6035294 † E=6,55	6035300 † E=6,85
7057947 E=0,10	6031106 E=8,4	6036875 E=7,8		6035289 † E=6,3	6035295 † E=6,6	
	6031105 E=8,3	6036874 E=7,7		6035290 † E=6,35	6035296 † E=6,65	
	6033399 E=8,2	6035063 E=7,6		6035291 † E=6,4	6035297 † E=6,7	

XXXX
0000

48	06-00
----	-------

	XXXX 0000	XXXX 0000	!!!
	n°...	n°...	
(a)	1 BP	500990	60
(b)	500991 BP	...	
(c)	1 BP	500990	
(d)	1 BP	288159	48
(e)	296584 BP	500990	48
(f)	208460 BP	...	
(g)			78
(h)	1 BP	392817	
	402062 BP	405724	
(j)	392818 BP	402061	
	405725 BP	...	
(k)	288160 BP	296583	48
(m)	296584 BP	...	
(n)			78
(p)	1 BP	86500	

!!!

80		5523873 -1- 5536809 -1- 1080 171256 -1-
78		6047509 -1-
79		06-00

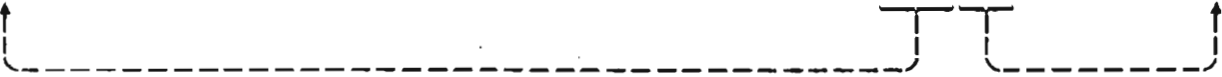

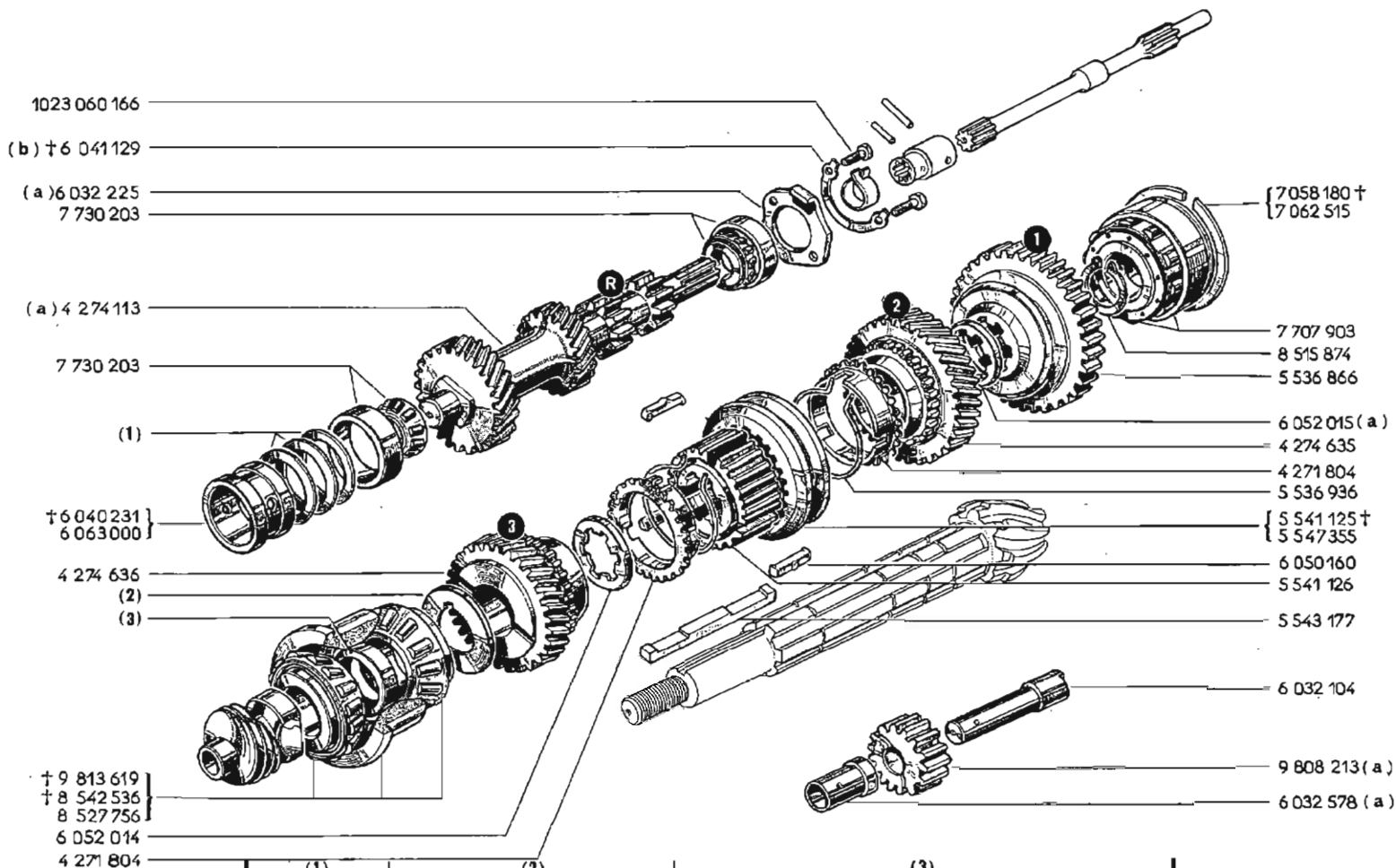

(1)		(2)		(3)	
7057944 E=0,95	6053522 E=4,3	6053516 E=3,7	6035286 † E=6,15	6035292 † E=6,45	6035298 † E=6,75
7057945 E=0,50	6053521 E=4,2	6053515 E=3,6	6035287 † E=6,2	6035293 † E=6,5	6035299 † E=6,8
7057946 E=0,20	6053520 E=4,1	6053514 E=3,5	6035288 † E=6,25	6035294 † E=6,55	6035300 † E=6,85
7057947 E=0,10	6053519 E=4	6054477 E=3,4	6035289 † E=6,3	6035295 † E=6,6	
	6053518 E=3,9	6054478 E=3,3	6035290 † E=6,35	6035296 † E=6,65	
	6053517 E=3,8		6035291 † E=6,4	6035297 † E=6,7	

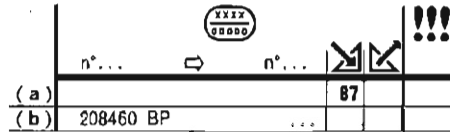
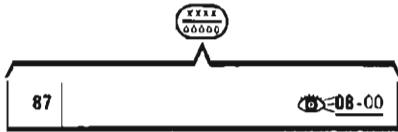

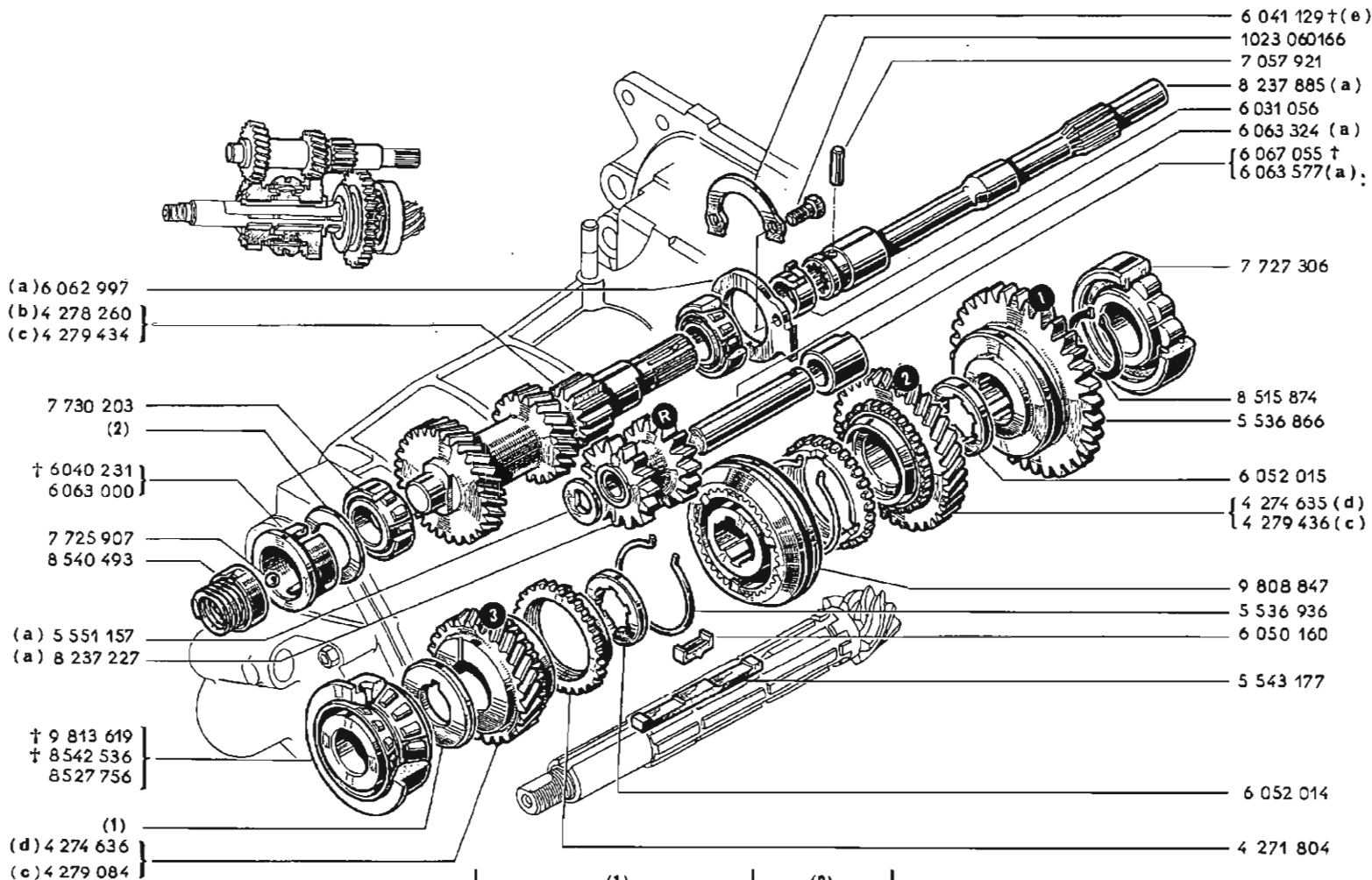

(1)		(2)	
6053522 E=4,3	6053516 E=3,7	7057944 E=0,95	
6053521 E=4,2	6053515 E=3,6	7057945 E=0,50	
6053520 E=4,1	6053514 E=3,5	7057946 E=0,20	
6053519 E=4	6054477 E=3,4	7057947 E=0,10	
6053518 E=3,9	6054478 E=3,3		
6053517 E=3,8			

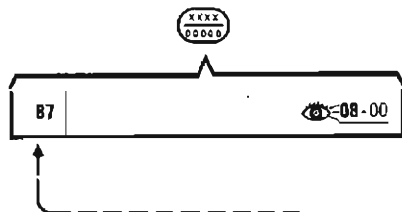

	n°...	⇨	n°...	↘	↙	!!!
(a)						87
(b)	841461 VEH		879969			87
(c)	879970 VEH		...			
(d)	841461 VEH		879969			
(e)	208460 BP		...			

31.23

A P.R. 685



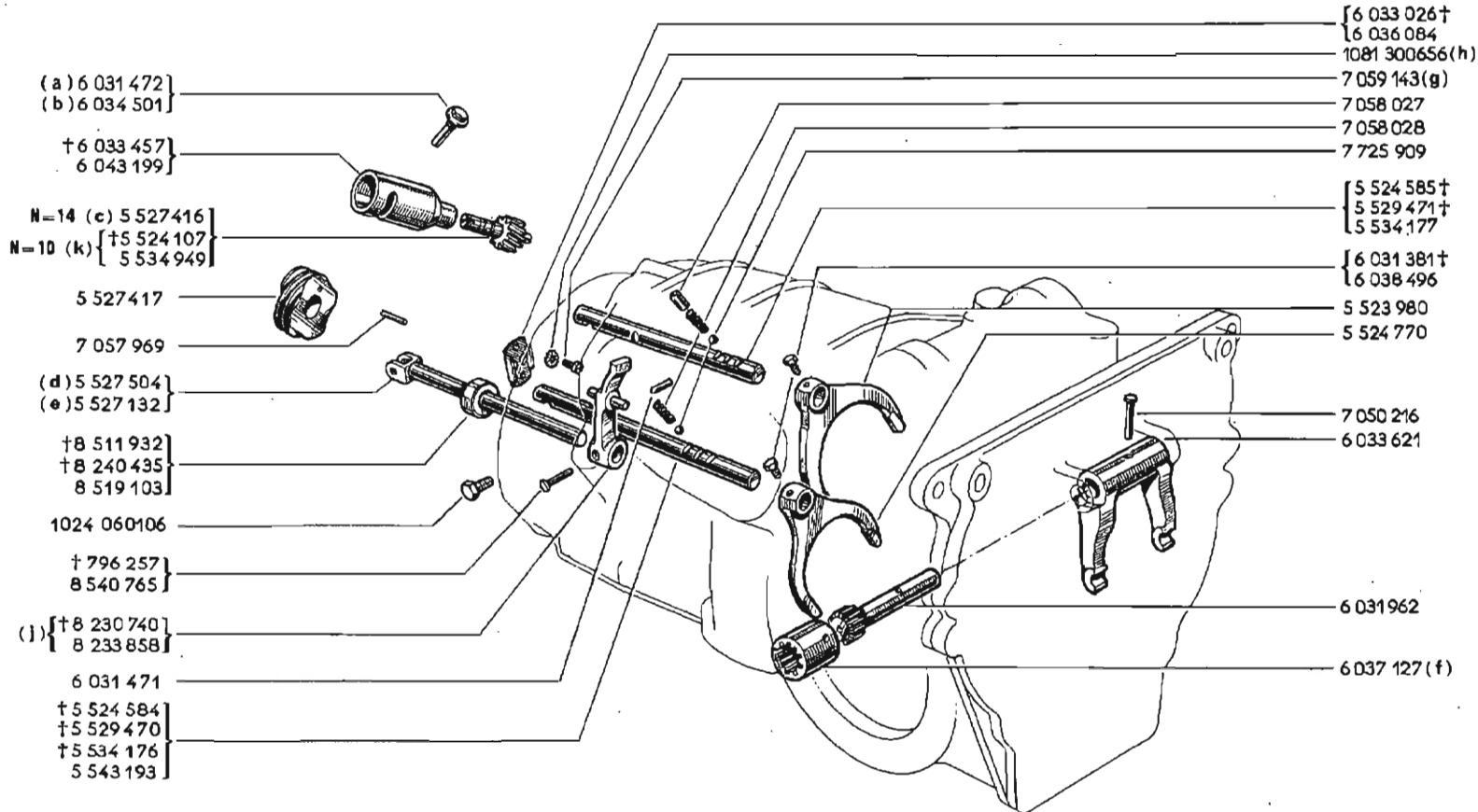

BP 3 - (R. 1060 - R. 2070)

31.23

A P.R. 685





XXXX
08300

25	 08-00
26	 08-00
37	 08-00
87	 08-00

XXXX
00000

	n°...	n°...	!!!	!!!
(a)	1 BP	2364		
(b)	2365 BP	...		
(c)			37	
(d)	BP	15264	87	
(e)	15265 BP	...		
(f)	1 VEH	450603	28	25
(g)			87	80
(h)			87	
(i)				81
(k)			37	



!!!

80	 1081 300856 -1-
81	 6049388 -2-

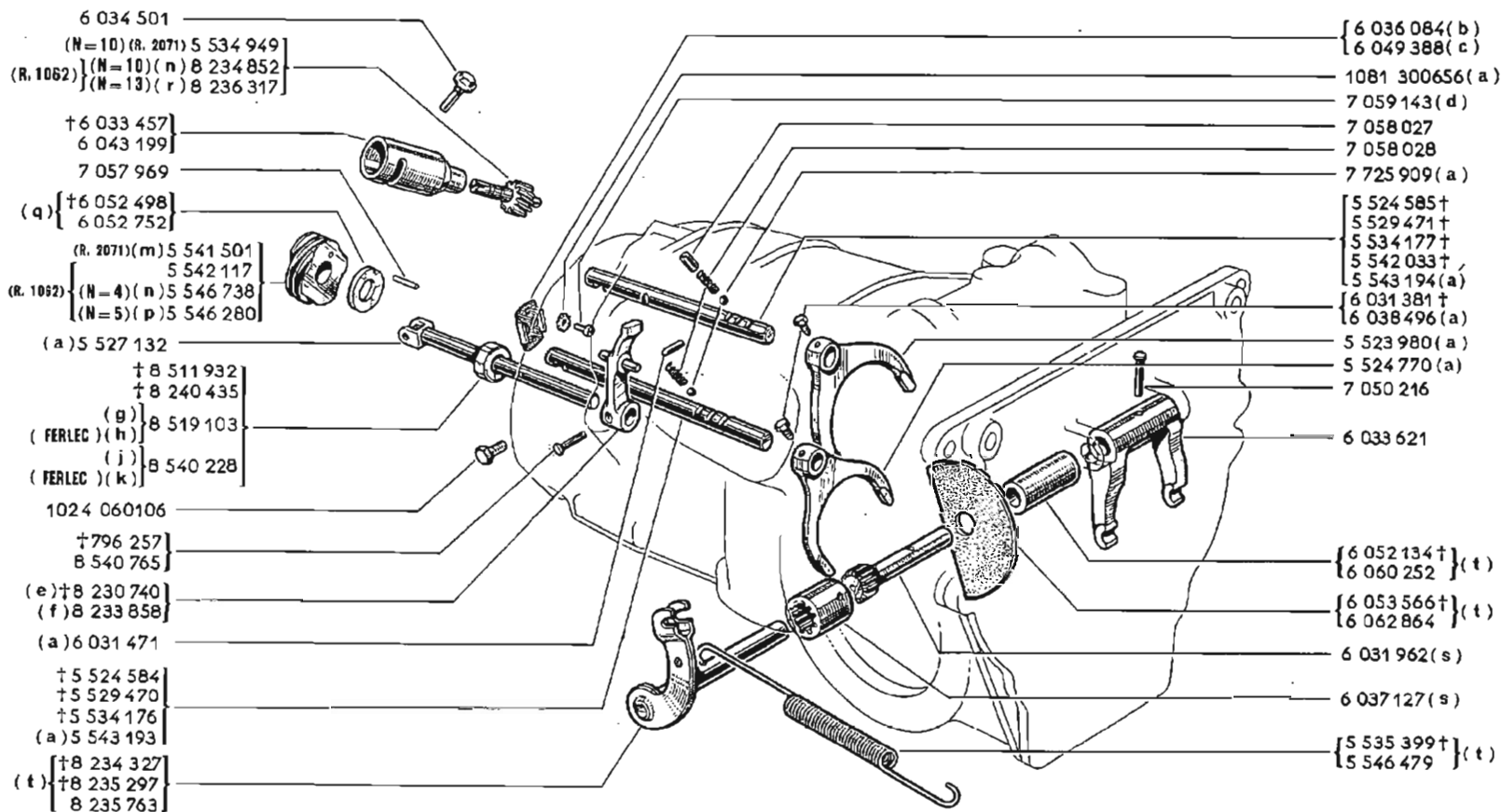









XXXX
80000

25	 08-00
26	 08-00
87	 08-00

XXXX
80000

	n°...	n°...			
(a)			87		
(b)	1 BP	589501			
	601946 BP	604084			
(c)	589502 BP	601945			
	604085 BP	...			
(d)			87		80
(e)					81
(f)			87		81
(g)	1 BP	255990	87		
(h)	1 BP	17794			
(j)	255991 BP	...		87	
(k)	17795 BP	...			
(m)					82
(n)	1 VEH	259365			
(p)	259366 VEH	...			
(q)	518130 BP	...			
(r)	259366 VEH	...	87		
(s)	1 VEH	450603	26	25	
(t)	450604 VEH	...	25	26	

!!!

80		1081 300656 -1-
81		6048388 -2-
82		8052752 -1- 1081 101250 -1-



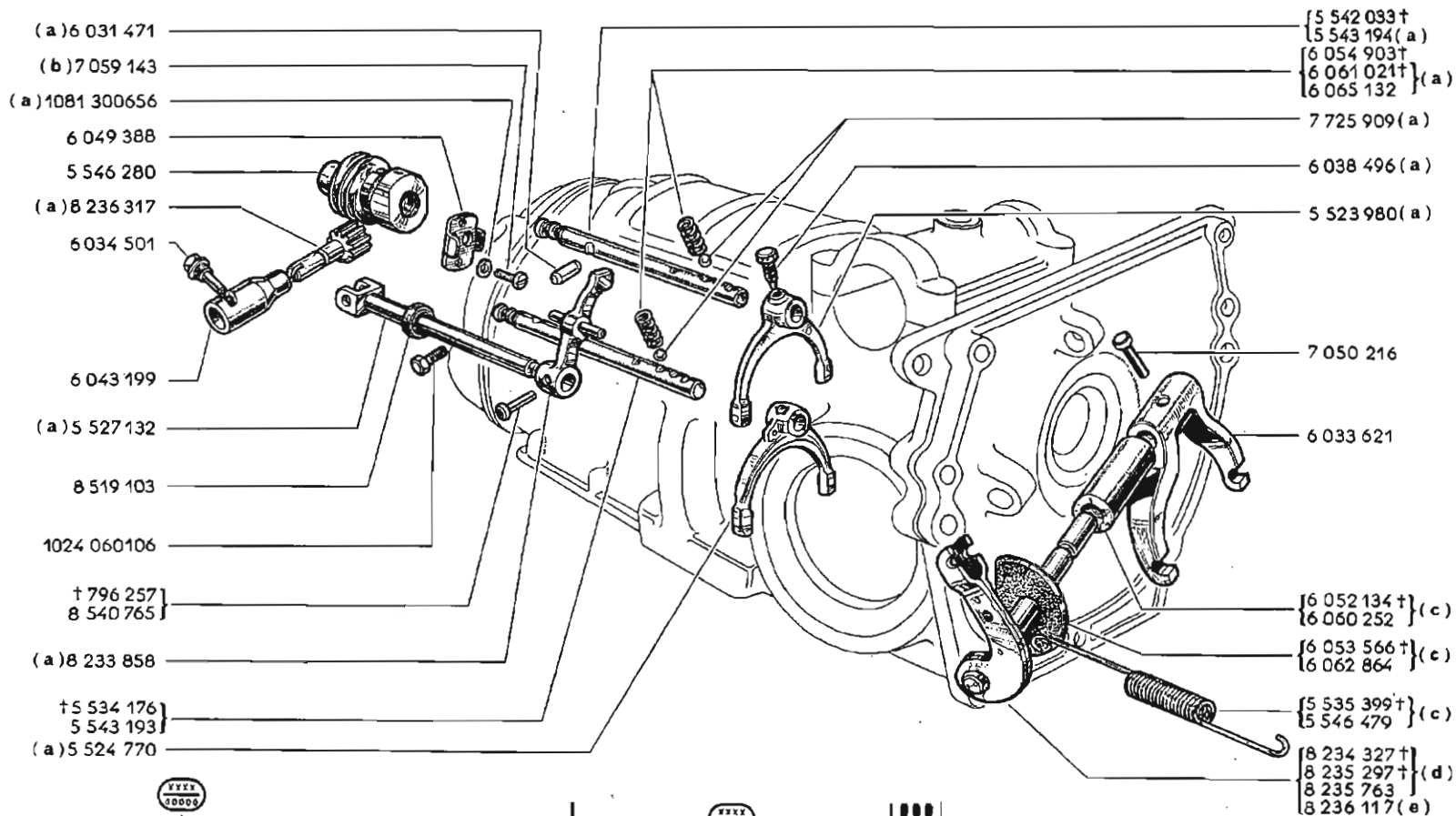

25	08-00
28	08-00
87	08-00



n°...	⇨	n°...			!!!
(a)			87		80
(b)			87		80
(c)			25	28	
(d)	450604 VEH	629051	25	28	
(e)	629052 VEH	...			



80		1081 300656 -1-
----	--	-----------------



(b) }
FERLEC (c) } 5 549 349 }
(d) }
FERLEC (e) } 5 552 540 }

(a) † 5 550 927 }
5 553 102 }

(a) 8 539 375

(a) 5 549 340

† 6 064 052 }

6 062 998 }

(a) 7 725 907

(a) 6 062 996

1081 110856

6 034 501

(a) N.13 8 300 098 }

N.12 8 300 097 }

5 546 280

6 043 199

(a) 5 551 057

(a) 8 540 228

{ 5 550 926 † (a) }
{ 5 553 101 }

6 033 621 (f)

7 050 216 (f)

{ 6 052 134 † (h) }
{ 6 060 252 }

{ 6 053 566 † (h) }
{ 6 062 864 }

8 236 117 (f)

8 540 765

5 550 569

{ 5 535 399 † (h) }
{ 5 546 479 }

5 552 361 (g)

4 279 966 (g)

6 068 078 (g)

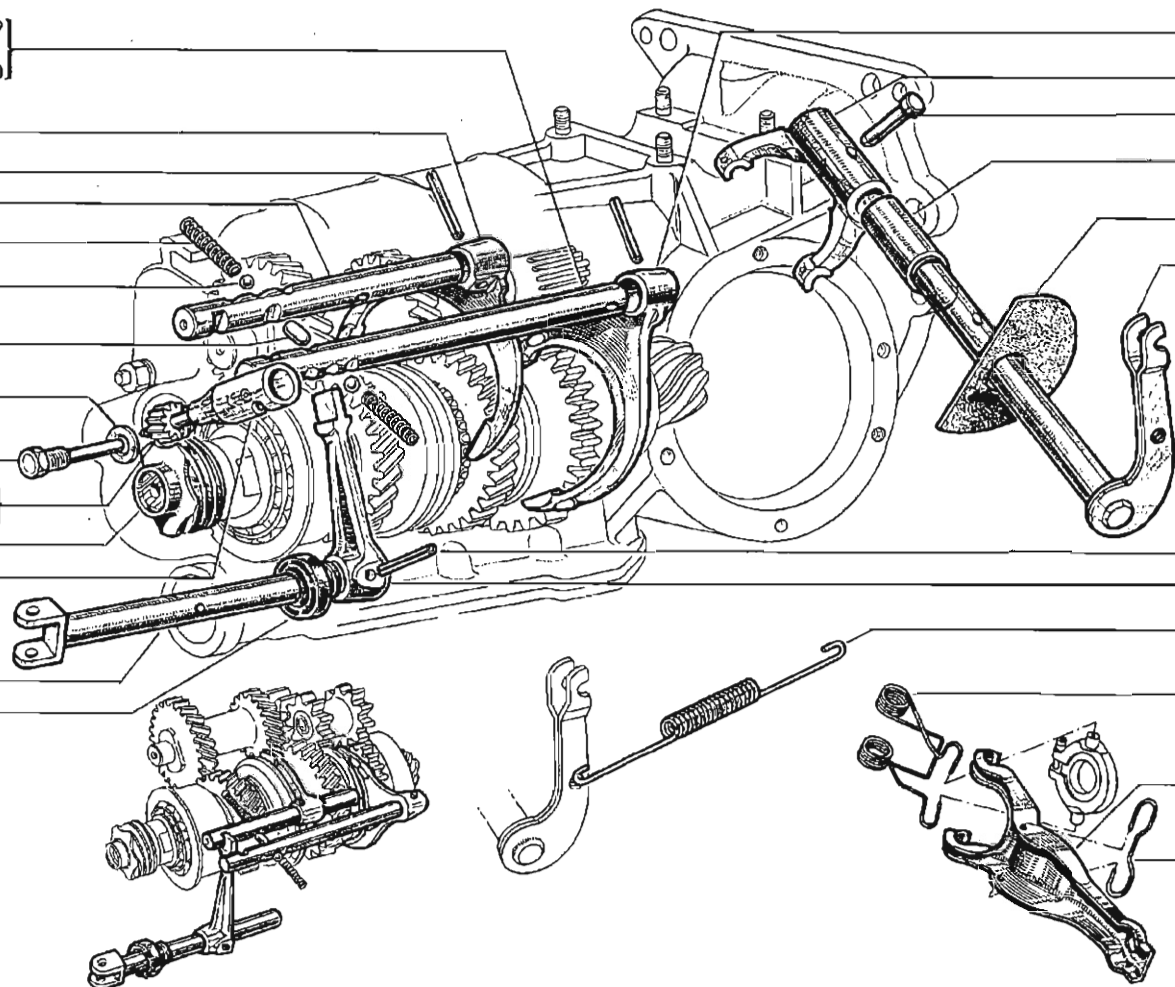

	XXXX 0000
25	08-00
26	08-00
87	08-00
88	08-00

	XXXX 0000		!!!
	n°...	n°...	
(a)			87
(b)	1 BP	23279	
(c)	1 BP	529	
(d)	23280 BP	...	
(e)	530 BP	...	
(f)	1 MOT	916908	88
(g)	916909 MOT	...	88
(h)	1 MOT	916908	25 28 88

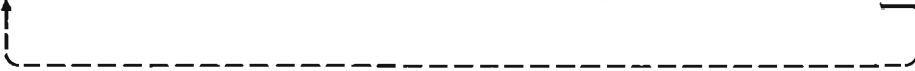

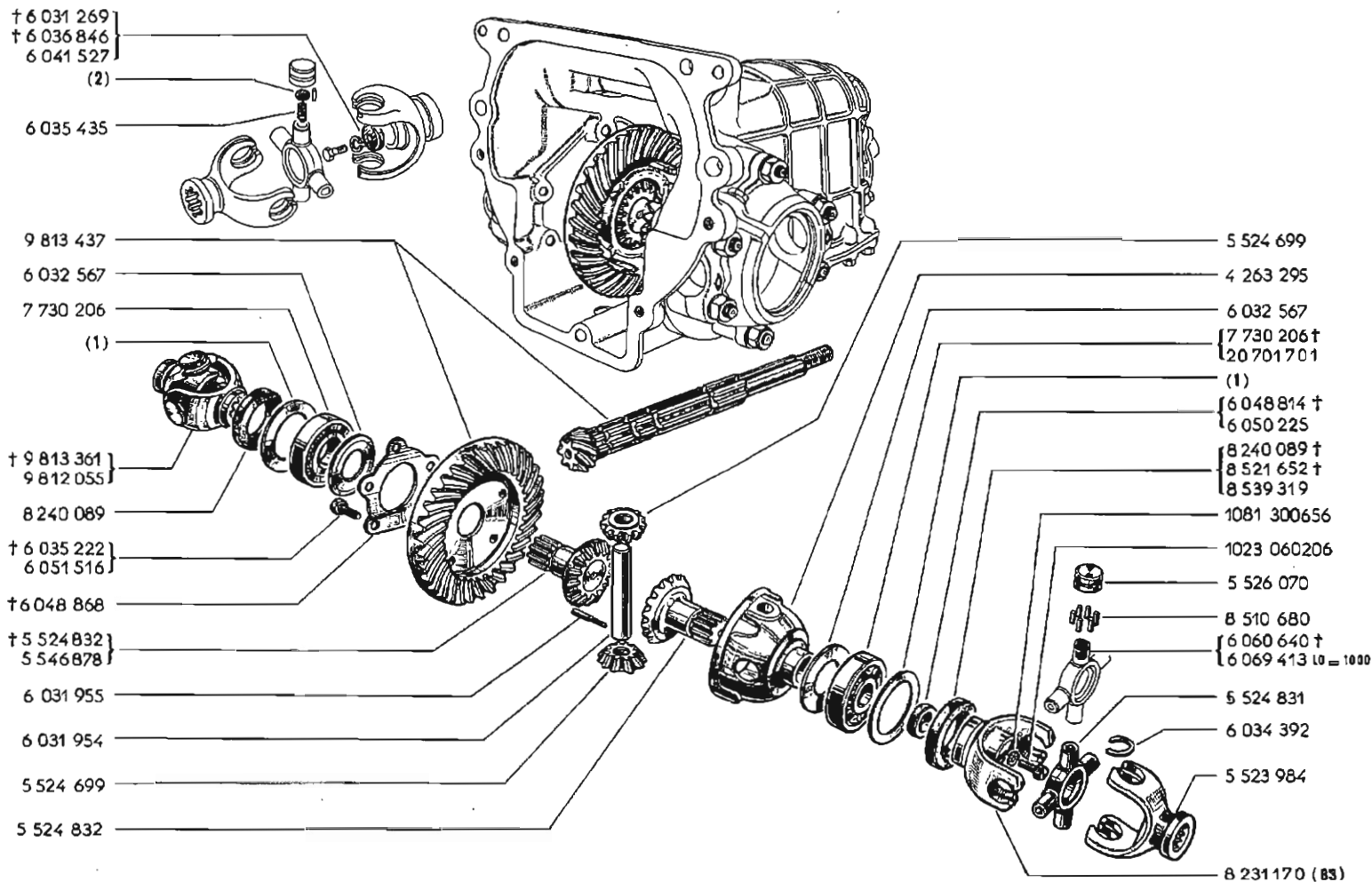

(1)		(2)	
4013866 E=0,95	4013869 E=0,10	7059951 E=0,10	
4013867 E=0,50	7062649 † E=0,05	7059952 E=0,20	
4013868 E=0,20	7062733 E=0,25	7059953 E=0,30	

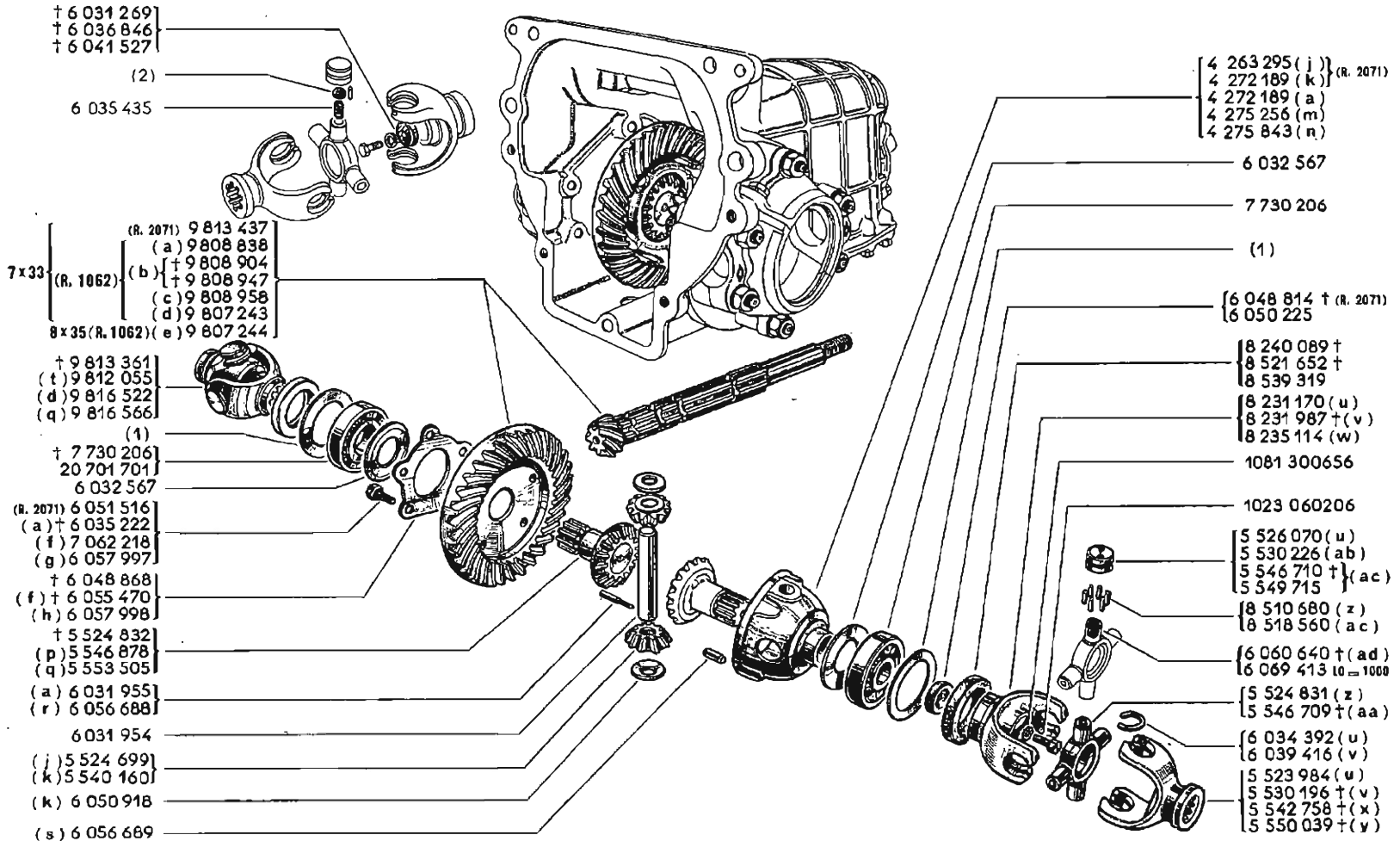

(1)		(2)	
4013866	E=0,95	7062649 †	E=0,05
4013867	E=0,50	7062733	E=0,25
4013868	E=0,20	7059951	E=0,10
4013869	E=0,10	7059952	E=0,20
		7059953	E=0,30

	n°...	n°...	!!!
(a)	1 BP	22598	
(b)	22599 BP	114394	181
(c)	22599 BP VEH 841460	87	181
(d)	841461 VEH MOT 916908	87	
(e)	916909 MOT	...	282
(f)	22599 BP	114394	
(g)	114395 BP	...	
(h)	22599 BP	...	
(i)	1 BP	504701	
(k)	504702 BP	...	
(m)	22599 BP	114394	63
(n)	114395 BP	...	63
(p)	1 MOT	916908	
(q)	916909 MOT	...	
(r)	22599 BP	...	64
(s)	59320 BP	...	
(t)	1 VEH	841460	87
(u)	1 BP	221484	5
(v)	221485 BP	...	5
(w)	221485 BP	...	5 272
(x)	221485 BP VEH 841460	87	272
(y)	841461 VEH	...	87 273
(z)	1 BP	261207	
(aa)	261208 BP	...	272 273
(ab)	221485 BP	261207	5
(ac)	261208 BP	...	
(ad)	841461 VEH	...	87

	!!!
5	08-00
87	08-00

	!!!
63	6056888 -1- 8056889 -1-
64	6056889 -1-
181	4275843 -1- 6057997 -5- 6057996 -1-
272	9812055 -2-
273	9816522 -2-
282	08-00



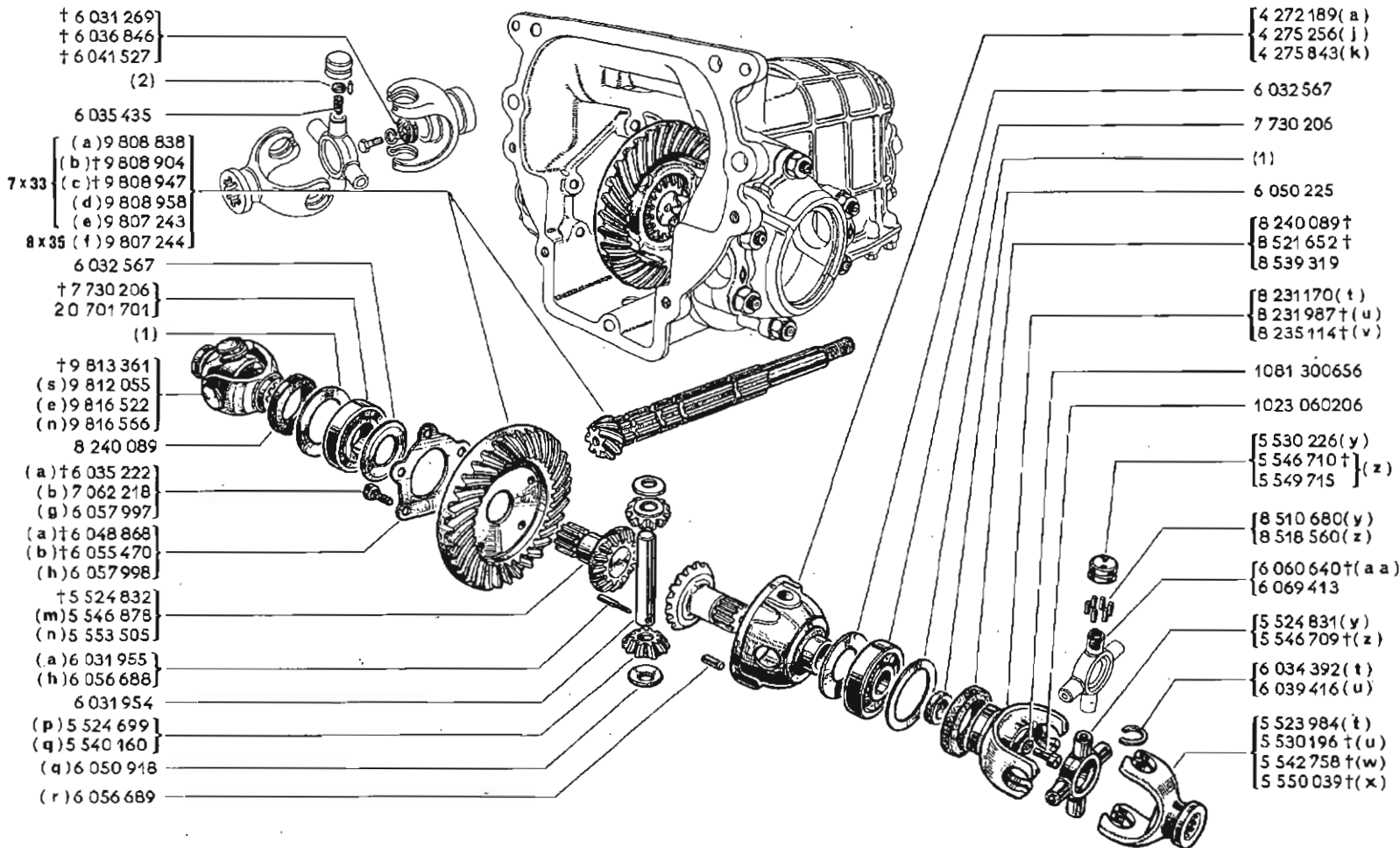

- † 6 031 269
- † 6 036 846
- † 6 041 527
- (2)
- 6 035 435
- (a) 9 808 838
- (b) † 9 808 904
- (c) † 9 808 947
- (d) 9 808 958
- (e) 9 807 243
- 8 x 35 (f) 9 807 244
- 6 032 567
- † 7 730 206
- 2 0 701 701
- (1)
- † 9 813 361
- (s) 9 812 055
- (e) 9 816 522
- (n) 9 816 566
- 8 240 089
- (a) † 6 035 222
- (b) 7 062 218
- (g) 6 057 997
- (a) † 6 048 868
- (b) † 6 055 470
- (h) 6 057 998
- † 5 524 832
- (m) 5 546 878
- (n) 5 553 505
- (a) 6 031 955
- (h) 6 056 688
- 6 031 954
- (p) 5 524 699
- (q) 5 540 160
- (q) 6 050 918
- (r) 6 056 689

- [4 272 189(a)
- [4 275 256(j)
- [4 275 843(k)
- 6 032 567
- 7 730 206
- (1)
- 6 050 225
- [8 240 089†
- [8 521 652†
- [8 539 319
- [8 231170(t)
- [8 231987†(u)
- [8 235 114†(v)
- 1081 300656
- 1023 060206
- [5 530 226(y)
- [5 546 710†
- [5 549 715](z)
- [8 510 680(y)
- [8 518 560(z)
- [6 060 640†(a a)
- [6 069 413
- [5 524 831(y)
- [5 546 709†(z)
- [6 034 392(t)
- [6 039 416(u)
- [5 523 984(t)
- [5 530 196†(u)
- [5 542 758†(w)
- [5 550 039†(x)

(1)		(1)	
4013866 E=0,95	7062649 † E=0,05	7059951 E=0,10	
4013867 E=0,50	7062733 † E=0,25	7059952 E=0,20	
4013868 E=0,20		7059953 E=0,30	
4013869 E=0,10			

	n°...		n°...	!!!	!!!
(a)	1 BP		1142		
(b)	1143 BP		7574		
(c)	1143 BP		7574		181
(d)	1143 BP	VEH 841460		87	181
(e)	841461 VEH	MOT 916908		87	
(f)	916909 MOT	...			282
(g)	7575 BP	...			
(h)	1143 BP	...			
(j)	1143 BP	7574			63
(k)	7575 BP	...			63
(m)	1 MOT	916908			
(n)	916909 MOT	...			
(p)	1 BP	504701			
(q)	504702 BP	...			
(r)	2959 BP	...			
(s)	1 VEH	841460	87		
(t)	1 BP	221484		5	
(u)	221485 BP	...	5		
(v)	221485 BP	...	5		272
(w)	1 VEH	841460	87		272
(x)	841461 VEH	...		87	273
(y)	1 BP	18089			
(z)	18090 BP	...			
(aa)	841461 VEH	...	87		

XXXX 00000	
6	08-00
87	08-00

!!!		
63	⚖️	6056688 -1- 6056689 -1-
181	⚖️	4275843 -1- 6057997 -5- 6057996 -1-
272	⊕	9812055 -2-
273	⊕	9816522 -2-
282		05-00

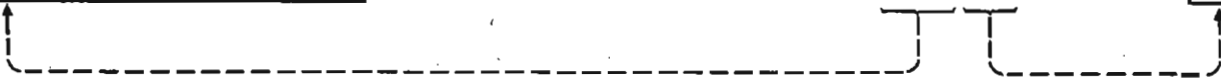

9 807 295

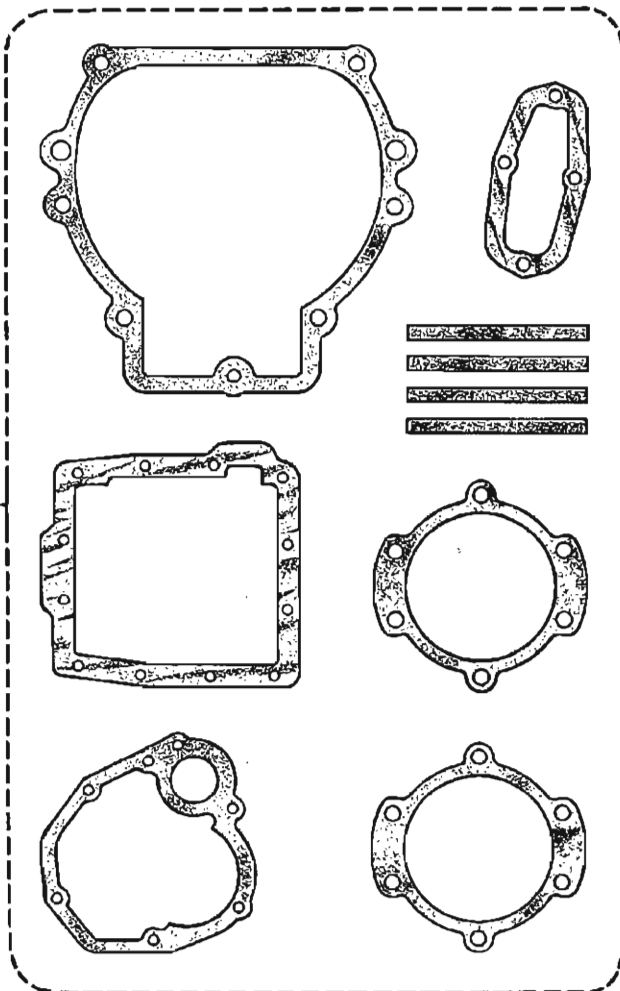

9 807 394

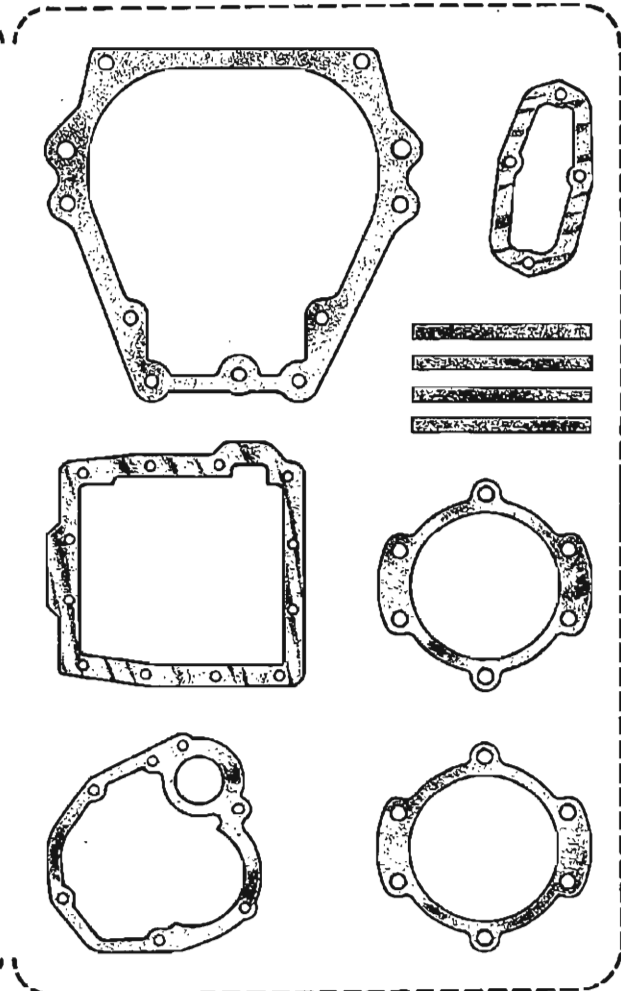

(a) MOT n° 1 ⇨ MOT n° 916908
(b) MOT n° 916909 ⇨ MOT n° ...

(R. 1080)
(R. 2070)
(a) (R. 1082)
(R. 2072)

(R. 1082) (b)

A P.R. 685

A P.R. 685

- 6 034 727
- † 7 058 403
- 7 061 288
- 1080 140856
- 6 036 094
- 6 036 299
- 1024 060306
- † 7 058 642
- † 7 061 059
- 6 060 811
- 6 033 739
- † 6 034 483
- † 6 045 024
- 6 052 682
- 8 105 771
- 1080 100656
- 1080 140856
- 1 222 288
- 6 031 275
- 8 511 108
- ☞ 9 819 065
- ☞ 9 819 064
- 1016 060166
- 7 058 156
- † 6 032 970
- 5 529 436
- 6 032 832
- 6 031 277
- ☞ { † 5 525 448
- 5 529 132
- 6 032 830
- 1080 100656
- 7 058 282
- † 6 032 831
- 6 053 453
- 7 706 203
- 6 031 233
- 1080 140856
- 6 033 589
- 6 033 590
- 1080 100656

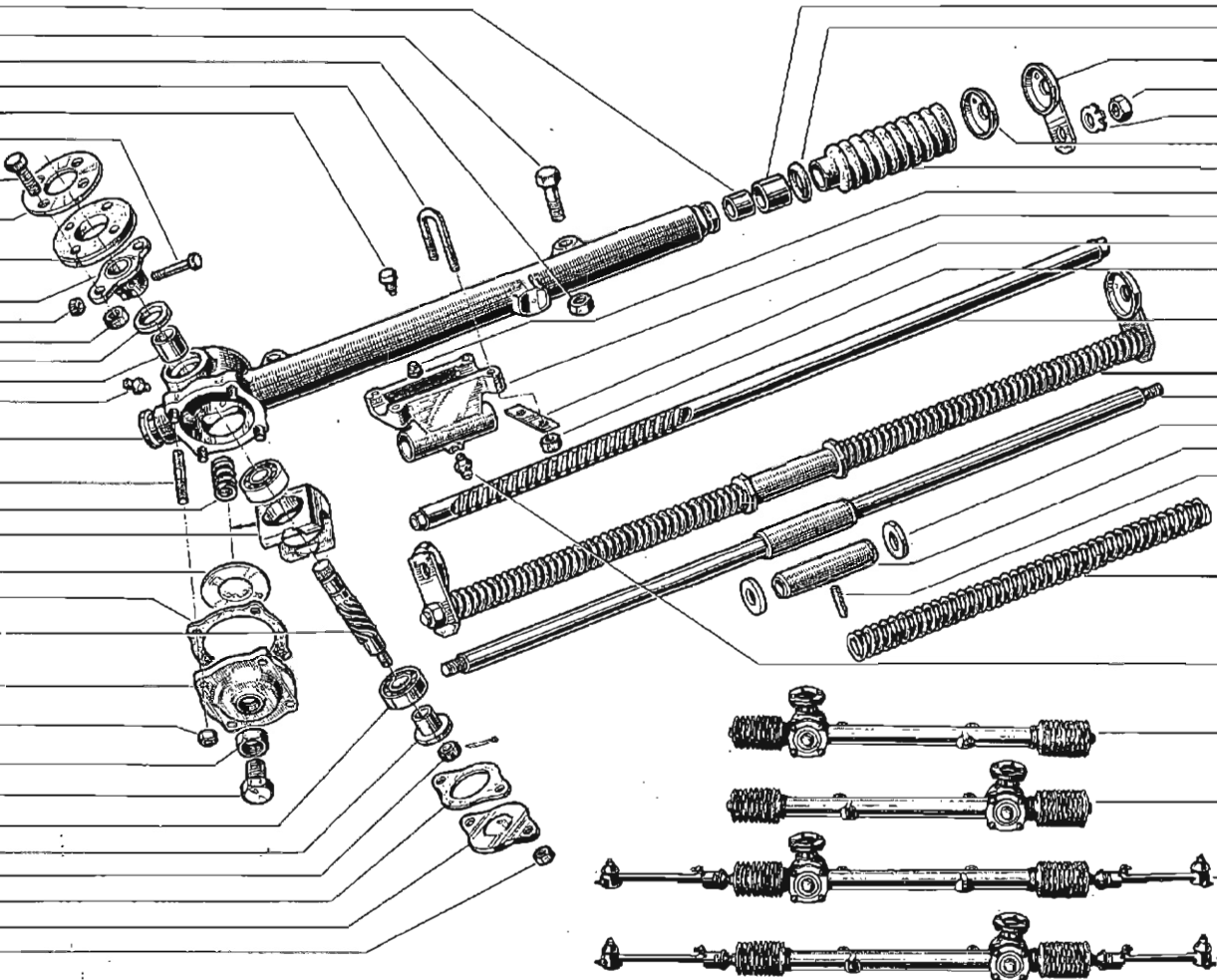

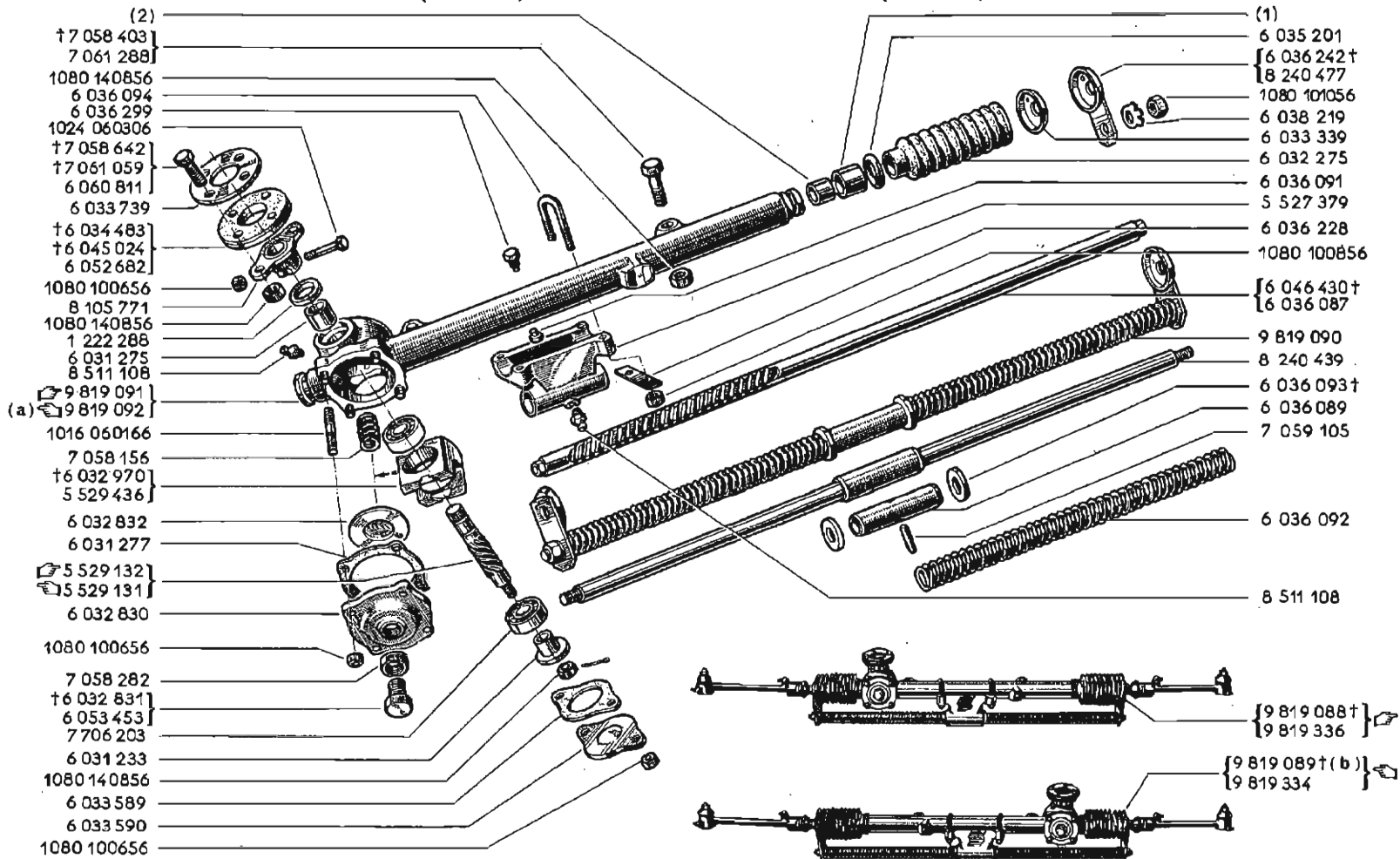

- 6 034 726
- 6 035 201
- 6 036 305 †
- 8 240 506
- 1080 101056
- 6 038 219
- 6 033 339
- 6 032 275
- 6 036 091
- 6 036 302
- 6 036 301
- 1080 100856
- 6 046 430 †
- 6 036 087
- 9 819 096
- 8 240 462
- 6 036 093 †
- 6 036 089
- 7 059 105
- 6 036 092
- 8 511 108
- 9 819 066 ☞
- 9 819 067 ☞
- 9 819 071 ☞
- 9 819 072 ☞





(1)	(2)
6034726 01=20 (c)	6034727 01=20 (c)
6051019 01=19,94 (d)	6051020 01=19,94 (d)

XXXX
00000

27	 08-00
28	 08-00

XXXX
00000

n°...	⇨	n°...			!!!
(a)					65
(b)			27	28	
(c)	1 DIR	447000			
(d)	447001 DIR	...			

!!!

65		6051019 -2- 6051020 -1-
----	---	----------------------------

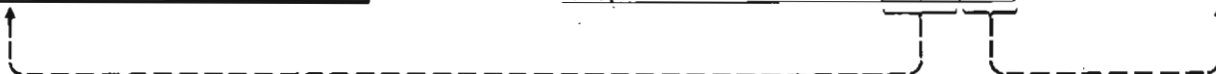

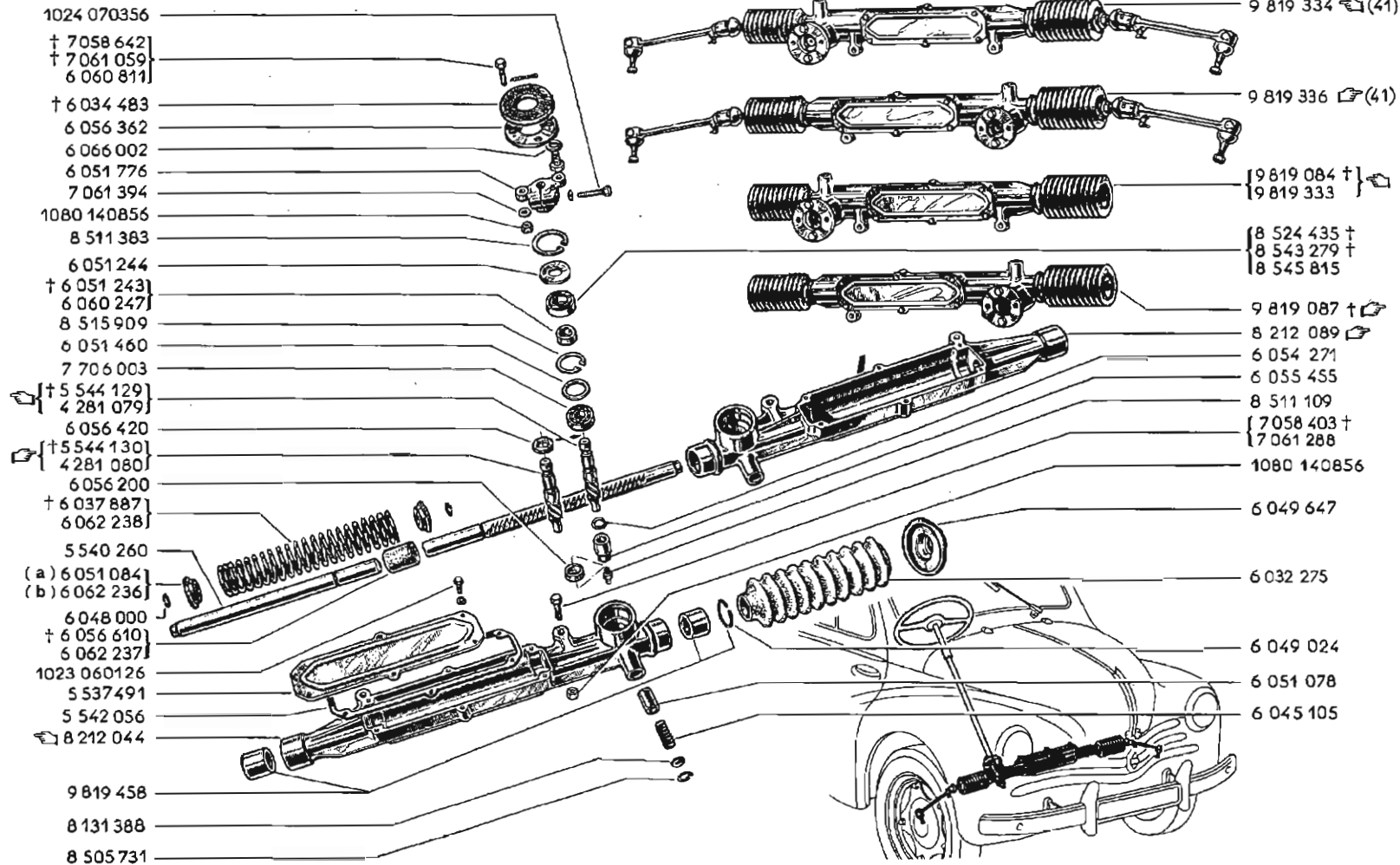

(a) DIR n° 1 ⇨ DIR n° 318040
 (b) DIR n° 318040 ⇨ DIR n° ...

41		6034665 -2-
		5542478 -7-
		5542477 -1-

40.20

A P.R. 685

(R. 1060) (R. 2070)

40.20

A P.R. 685

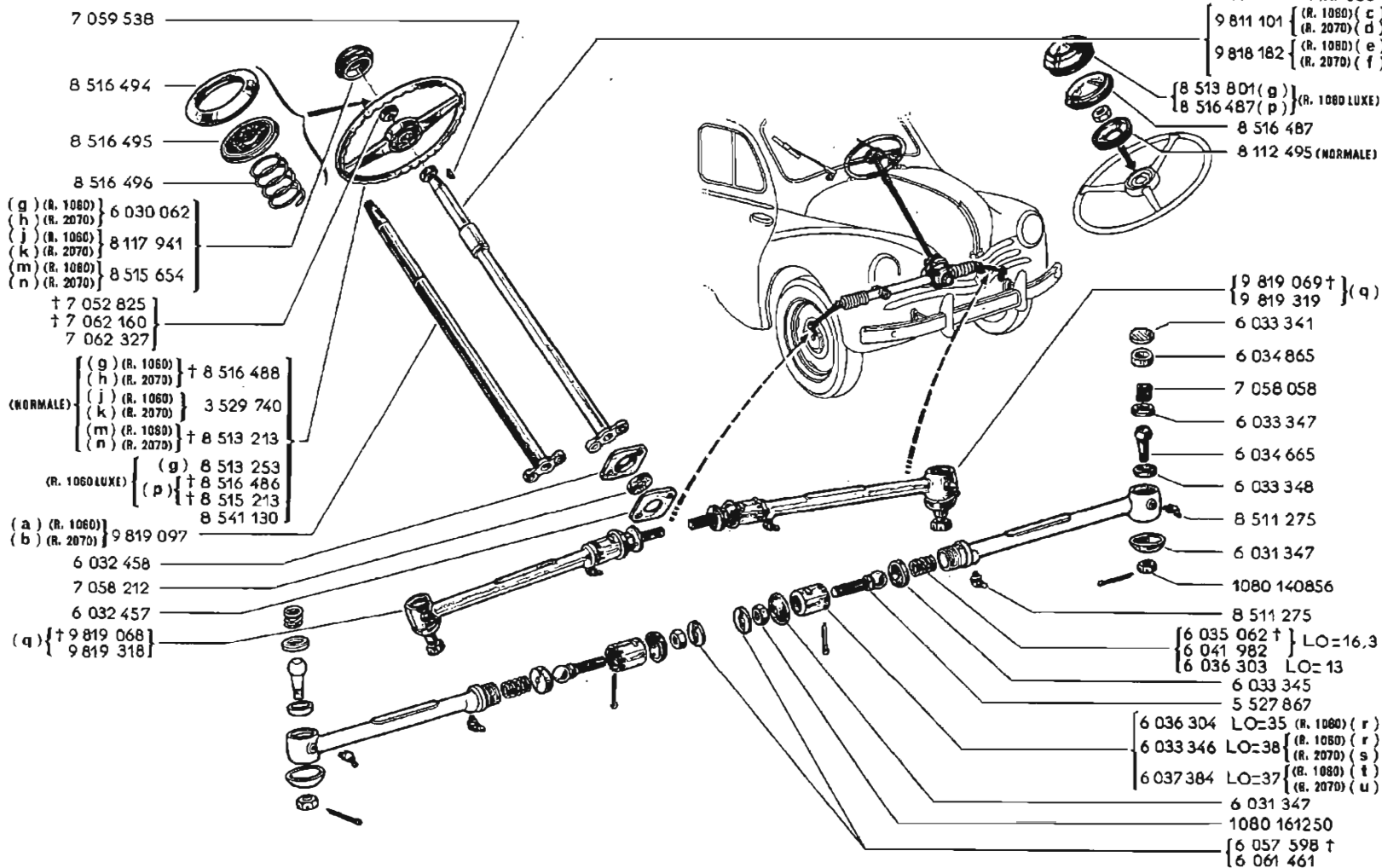

	n°...	n°...	!!!
(a)	1 VEH	21785	
(b)	1 VEH	2789	
(c)	21786 VEH	64483	
(d)	2790 VEH	8012	
(e)	64484 VEH	...	158 157
(f)	8013 VEH	...	157
(g)	1 VEH	64483	
(h)	1 VEH	8012	
(i)	64484 VEH	103246	
(k)	8013 VEH	9908	
(m)	103247 VEH	...	
(n)	9909 VEH	...	
(p)	64484 VEH	...	
(q)			67
(r)	1 VEH	6828	
(s)	1 VEH	962	
(t)	6829 VEH	...	
(u)	963 VEH	...	

!!!

67	☞	6036845 -1-
156	☞	8029057 -1-
157	☞	6041568 -2-



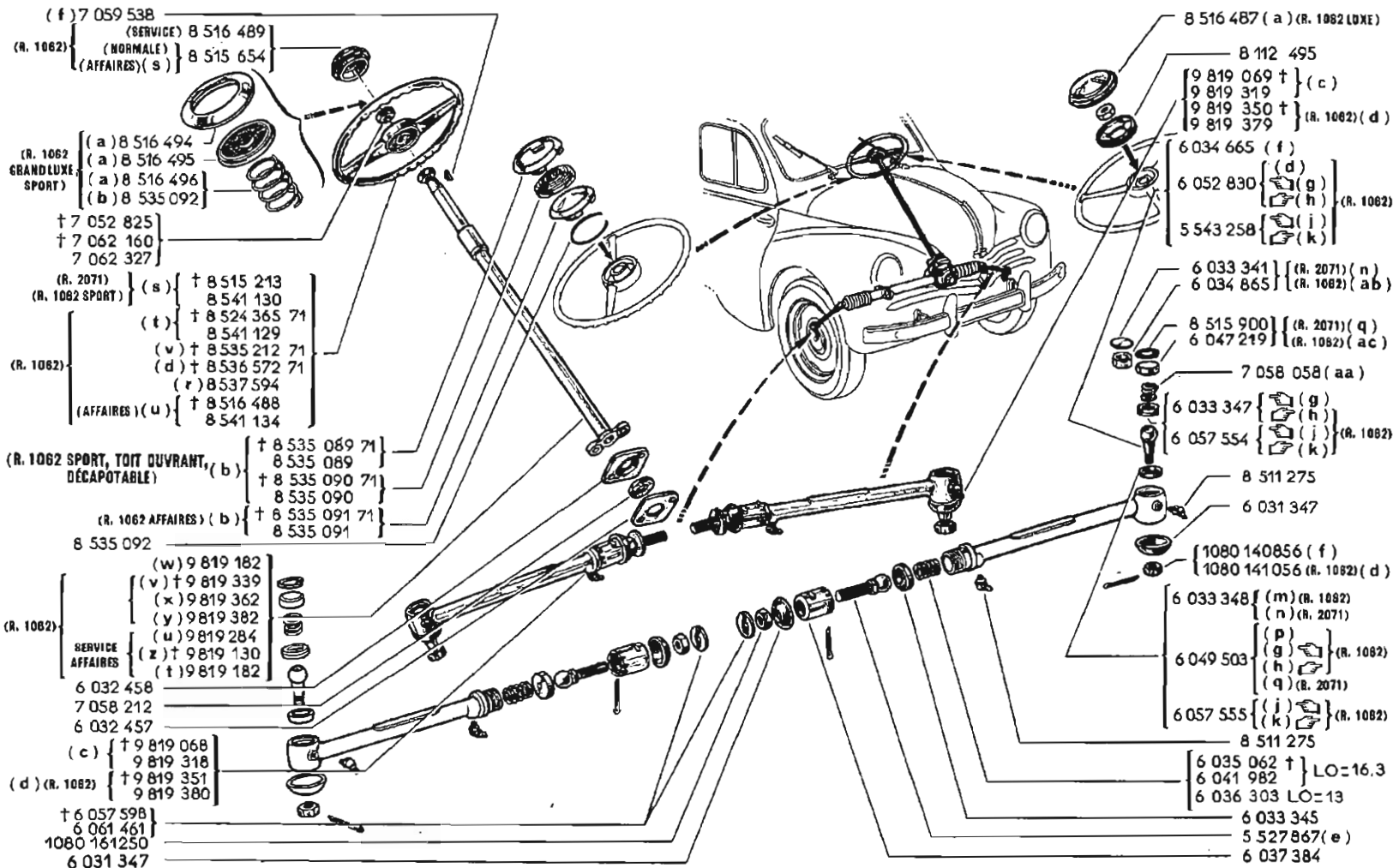

<div style="text-align: center;"> XXXX 00000 </div>	
27	☞ 08-00
28	☞ 08-00
32	☞ 08-00

	n°...	n°...	☞	☞	!!!
(a)	1 VEH 405601 VEH	405209 406426			
(b)	405210 VEH 406427 VEH	405600 ...			
(c)	1 VEH	461432	27	28	87
(d)	461433 VEH	...	28	27	
(e)					86
(f)	1 VEH	461432	27	28	
(g)	1 DIR	167399			
(h)	1 DIR	5307			
(j)	167400 DIR	...			
(k)	5308 DIR	...			
(m)	1 VEH	326131			
(n)	1 VEH	4240			
(p)	326132 VEH	...			
(q)	4241 VEH	...			
(r)	461433 VEH	...			
(s)	1 VEH	405209			
(t)	405210 VEH 406427 VEH	405600 461432	27	28	
(u)	1 VEH 405601 VEH	405209 406426			
(v)	461433 VEH	532892	28	27 32	
(w)	1 VEH	461432	27	28	157
(x)	461433 VEH	631207	28	27	
(y)	631208 VEH	...			
(z)	405210 VEH	405600			157
(aa)					87
(ab)	1 VEH	355157			
(ac)	355158 VEH	...			

<div style="text-align: center;"> !!! </div>	
67	☞ 6036645 - 1 -
86	☞ 06-00
87	☞ 6034865 - 1 -
157	☞ 6041558 - 2 -



(a) { (R. 1080) (R. 2070) † 9 815 087
 (R. 1080) (R. 2070)
 (b) (R. 1082) } 9 814 443
 (c) (R. 2071) }

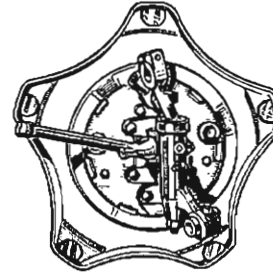
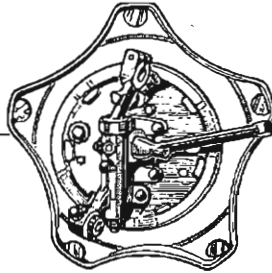

{ 9 815 088 † (R. 1080) (R. 2070) (a)
 9 814 444 { (R. 1080) (R. 2070)
 (R. 1082) (b)
 (R. 2071) (c) }

(d) (R. 1080) (R. 2070) † 9 815 108
 (d) (R. 1080) (R. 2070) }
 (e) (R. 1082) } 9 814 618
 (f) (R. 2071) }
 (g) (R. 1082) † 9 815 148
 (h) (R. 1082) } 9 815 527
 (i) (R. 2071) }

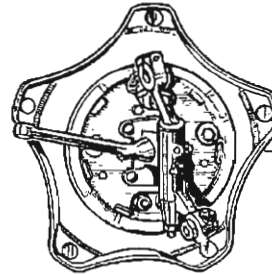
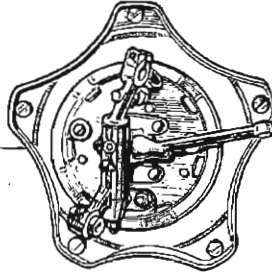

{ 9 815 109 † (R. 1080) (R. 2070) } (d)
 (R. 1080) (R. 2070)
 9 814 619 { (R. 1082) (e)
 (R. 2071) (f)
 9 815 147 † (R. 1082) (g)
 9 815 528 { (R. 1082) (h)
 (R. 2071) (i) }

(R. 1082) { (k) † 9 815 564
 (m) † 9 815 619
 (n) 9 815 786
 (p) 9 815 820 }

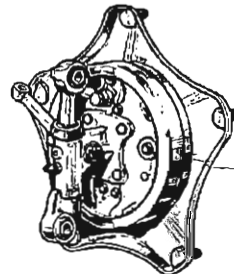
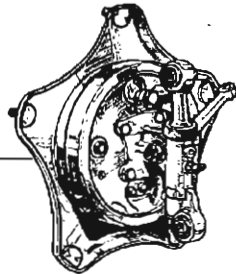

{ 9 815 565 † (k)
 9 815 620 † (m)
 9 815 787 (n)
 9 815 821 (p) } (R. 1082)

XXXX
00000

3	08-00
4	08-00
6	08-00
7	08-00
27	08-00
28	08-00
29	08-00
34	08-00
35	08-00
83	08-00

XXXX
00000

	n'...	n'...			
(a)					6 7
(b)	1 VEH 34445 VEH	32644 34507			
(c)	1 VEH	1470			
(d)					8 7
(e)	32645 VEH 34508 VEH	34444 252105	4	3	
(f)	1471 VEH	4240			
(g)	252106 VEH	461432	3 27	4 28	
(h)	252106 VEH	484678	3 29	4 28	88
(j)	4241 VEH	...			200
(k)	484679 VEH 502801 VEH	502640 502857	29		
(m)	484679 VEH 502801 VEH	502640 634187	35	34	
(n)	484679 VEH	748117			83 183
(p)	748118 VEH	...	83		

!!!

88		8052830 -f- 1080 141056 -f-
183		8236175 -f- 7082487 -f-
200		8236176 -f- 7062407 -f-



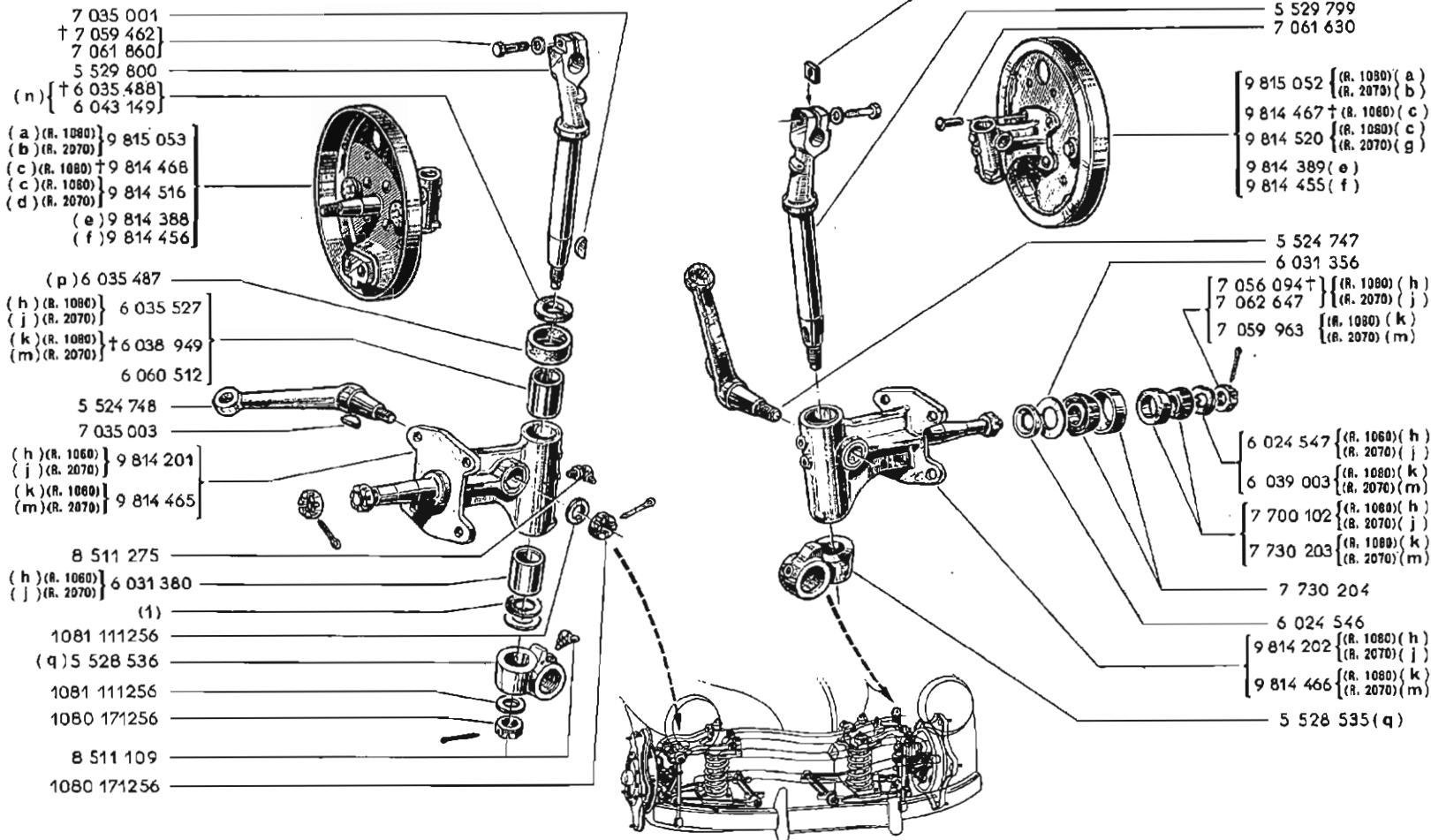

(1)
 8117972 E=0,2
 8117973 E=0,5

XXXX
00000

8	08-00
7	08-00
11	08-00

XXXX
00000

	n°...	n°...	⚡	⚡	!!!
(a)	1 VEH	107931		8	11
(b)	1 VEH	10036		8	11
(c)	107932 VEH	...	11	7	
(d)	10037 VEH	...	11	7	90
(e)				8	
(f)				7	
(g)	10037 VEH	...	11	7	91
(h)	1 VEH	107931		11	
(j)	1 VEH	10036		11	
(k)	107932 VEH	...	11		
(m)	10037 VEH	...	11		
(n)					7
(p)	14562 TAV	...			
(q)					8

!!!

7		06-00
8	8899006 -f-	
90	5531108 -f-	
91	5531107 -f-	



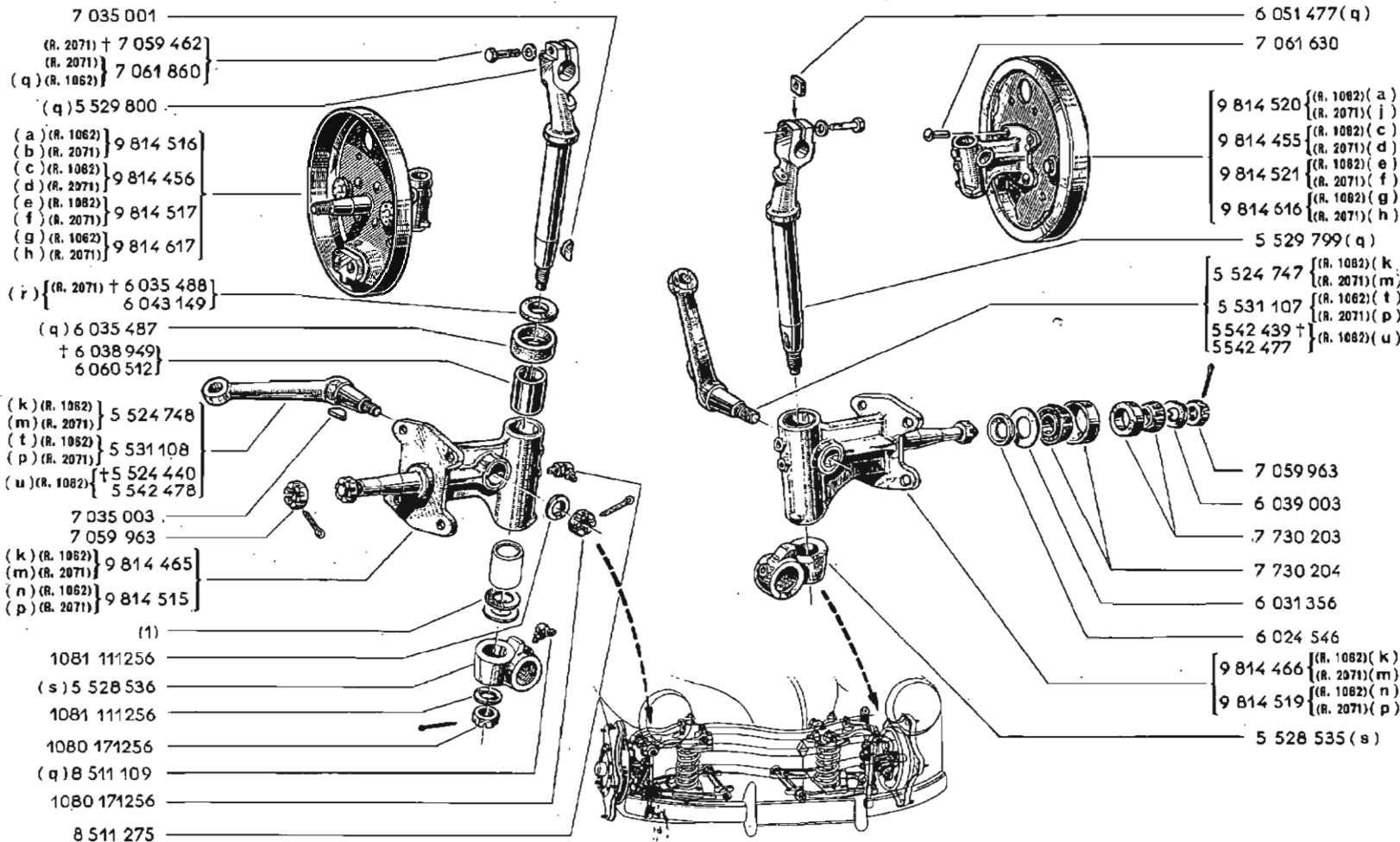

(1)
8117972 E=0,2
8117973 E=0,5

XXXX
00000

3	08-00
4	08-00
27	08-00
28	08-00
29	08-00

	n°...	n°...	⊗	⊗	!!!
(a)	1 VEH 34445 VEH	32644 34507			
(b)	1 VEH	1470			
(c)	32645 VEH 34508 VEH	34444 92669			
(d)	1471 VEH	3057			
(e)	92670 VEH	252105	4	3	
(f)	3058 VEH	4240			
(g)	252106 VEH	484678	3	4	
(h)	4241 VEH	...			
(j)	1 VEH	1470			91
(k)	1 VEH	92669			
(m)	1 VEH	3057			
(n)	92670 VEH	484678			
(p)	3058 VEH	...			
(q)				29	
(r)					7
(s)				29	8
(t)	92670 VEH	461432	27	28	
(u)	461433 VEH	484678	27	28	

!!!

7	06-00
8	6999006 -1-
91	5531107 -1-

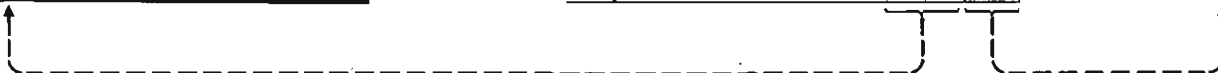

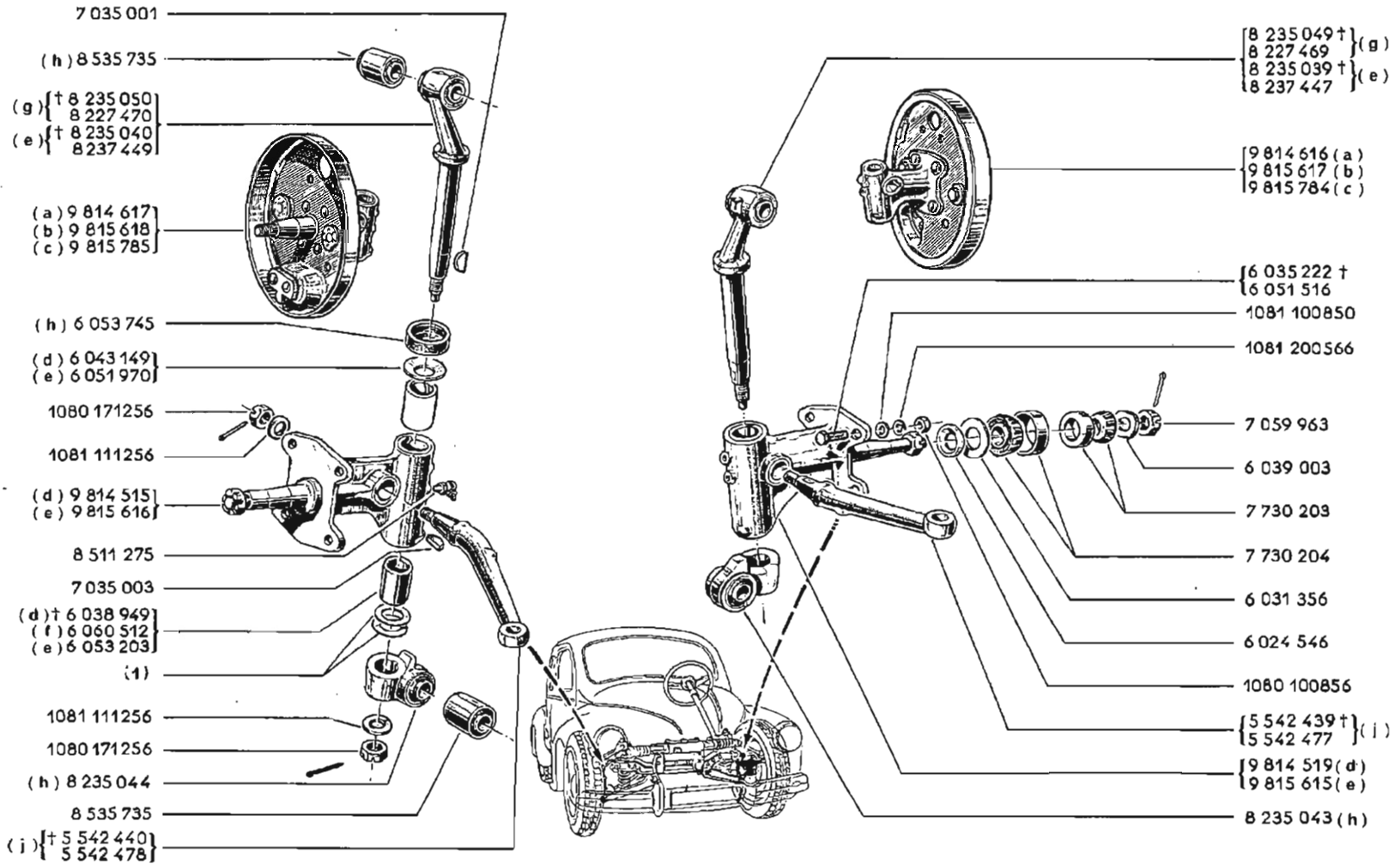

(1)
8117972 E=0,2
8117973 E=0,5

<div style="border: 1px solid black; border-radius: 50%; padding: 2px; display: inline-block;"> XXXY 00000 </div>	
3	08-00
4	08-00
27	08-00
28	08-00
29	08-00
34	08-00
35	08-00



<div style="border: 1px solid black; border-radius: 50%; padding: 2px; display: inline-block;"> XXXX 00000 </div>		<div style="border: 1px solid black; padding: 2px; display: inline-block;"> ↘ ↙ </div>		<div style="border: 1px solid black; padding: 2px; display: inline-block;"> !!! </div>	
n°...	⇨	n°...	↘	↙	
(a)	484679 VEH	502640	3	4	
	502801 VEH	502857			
(b)	502541 VEH	502800			
	502858 VEH	634187	35	34	
(c)	634188 VEH	...	34	35	
(d)	484679 VEH	502640			
	502801 VEH	502857			
(e)	502541 VEH	502800			
	502858 VEH	...			
(f)	502801 VEH	502857			
(g)	484679 VEH	502640	28		
	502801 VEH	502857			
(h)			29		
(i)			28	27	

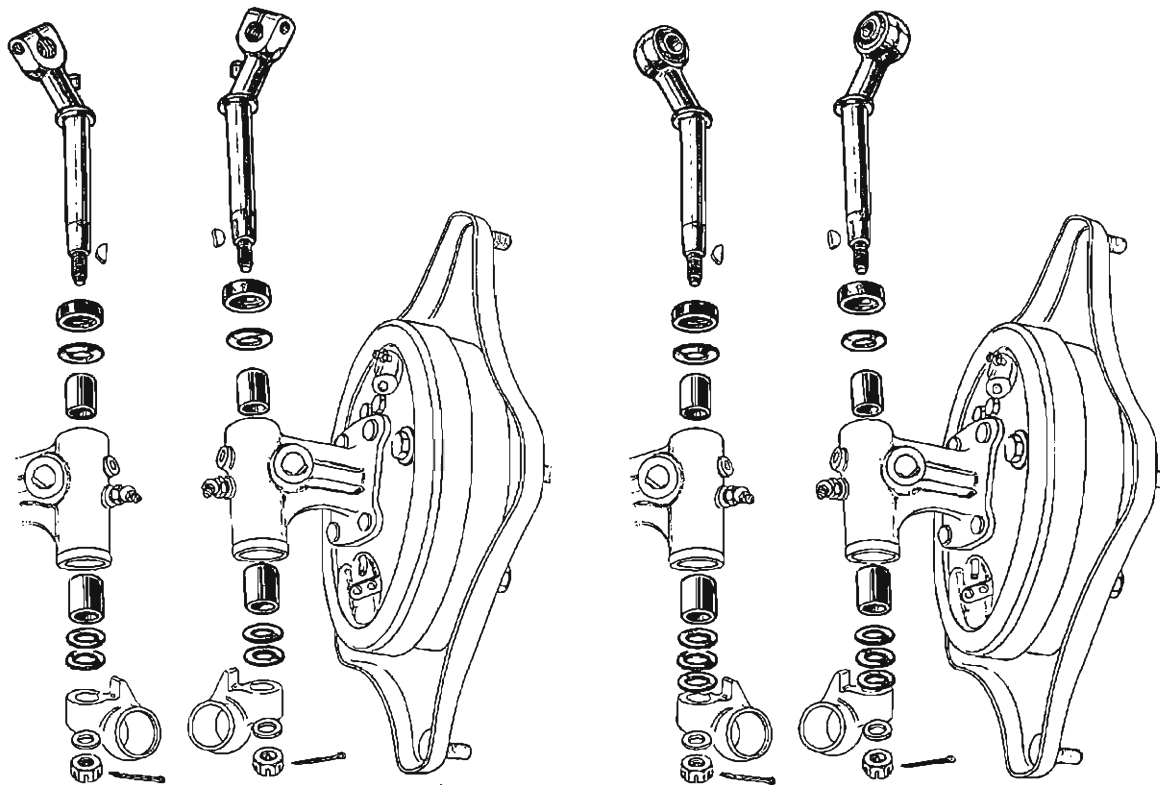



(a) (R. 1080) } 9 814 815
 (b) (R. 2070) }
 (c) (R. 1080) }
 (d) (R. 2070) } 9 814 814
 (e) (R. 1082) }
 (R. 2071) }

9 815 577 (R. 1082) (f)
 9 815 621 (R. 1082) (g)

11	 08-00
29	 08-00

XXXX
00000

	n°...	n°...	!!!
(a)	1 VEH 107931	11	
(b)	1 VEH 10036	11	
(c)	107932 VEH ...	11	
(d)	10037 VEH ...	11	
(e)	1 VEH 484678	29	
(f)	484679 VEH 502640	29	
	502801 VEH 502857		
(g)	502641 VEH 502800		
	502858 VEH ...		



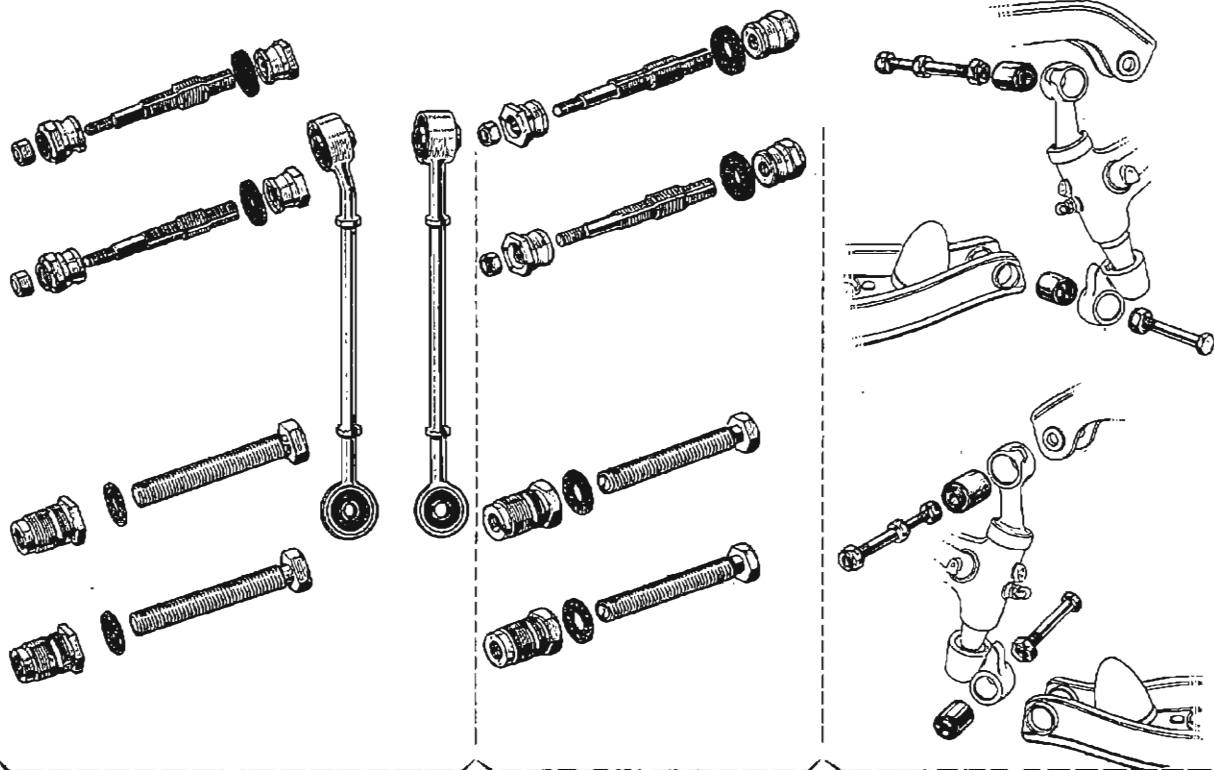

(a) (R. 1060)
(b) (R. 1082) } 9 8 1 4 8 1 6
(c) (R. 2070)
(d) (R. 2071)

9 8 1 4 8 1 3 { (R. 1082) (e)
(R. 2071) (f)

9 8 1 5 5 7 4 (R. 1082) (g)

XXXX
00000

29

08-00

XXXX
00000

!!!

	n°...	n°...		
(a)	49422 VEH	...		
(b)	1 VEH	119138		
	119232 VEH	151131		
(c)	1930 VEH	...		
(d)	1 VEH	4240		
(e)	119139 VEH	119231		
	151132 VEH	484678	29	
(f)	4241 VEH	...		
(g)	484679 VEH	...	29	

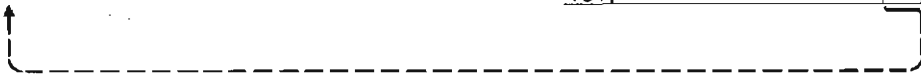

42.10

A P.R. 685

R. 1060

42.10

A P.R. 685

- (h) 1080 140856
- (k) † 8 231 367
- (m) 8 238 581
- (n) † 8 231 762
- 8 238 584

- (h) † 8 511 922
- (i) † 8 540 903
- (q) 8 543 250

- 8 511 109
- (e) 6 035 177
- (e) 6 035 178
- (e) 6 035 176
- LO=175 (a) 5 525 879
- LO=182 (b) 5 529 727
- † 7 059 493
- 7 061 220
- (f) 6 035 159
- 1081 210866
- † 1080 100856
- 1080 140856

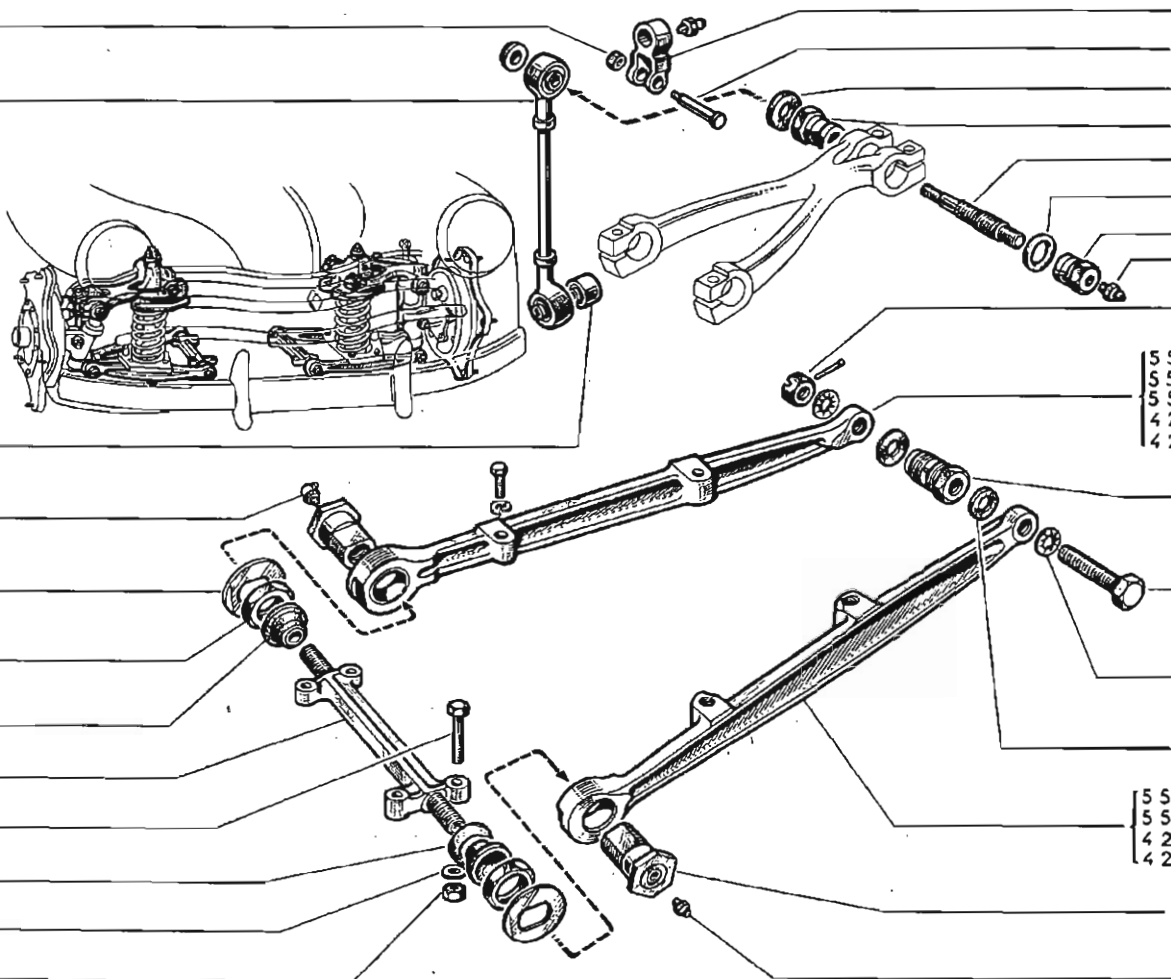

- 8 240 516
- { 6 037 365 †
- { 6 053 438 (h)
- 6 037 383 (i)
- 6 037 363
- 6 031 343
- 6 035 157
- 8 240 555
- 8 511 109
- { 1080 101246 †
- { 7 059 303 †
- { 1080 141456
- { 5 528 578 † (c)
- { 5 529 756
- { 5 528 526 (d)
- { 4 264 589 † (e) LO=323
- { 4 271 152
- { 6 031 348 † (c)
- { 6 999 006
- { 5 528 876 † (g)
- { 5 528 538
- { 6 031 378 † (c)
- { 6 057 080
- { 5 528 537 † (g)
- { 5 529 775
- { 1081 301256 †
- { 1081 311456
- { 6 035 158 (c)
- { 6 038 220 (g)
- { 5 529 755 (c)
- { 5 528 525 (d)
- { 4 264 756 † (e) LO=323
- { 4 271 153
- { 8 240 556 (f) LO=30
- { 8 240 384 (e) LO=33
- 8 511 108

	n°...	⇨	n°...	✓	✗	!!!
(a)				12	12	9
(b)				12		
(c)	1 VEH		42899			
(d)	42900 VEH		...		12	
(e)				12		
(f)					12	
(g)	42900 VEH		...			
(h)	25494 CAR		...			
(i)	2217 CAR		...			
(k)	25494 CAR		88141			
(m)	2217 CAR		88141			
(n)	88142 VEH		...			
(p)	1 VEH		880938			
(q)	880939 VEH		...			

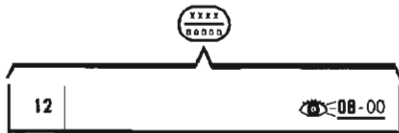

(h) 1080 140856

(j) { †8 231 367
8 238 581 }
(k) { †8 231 762
8 238 584 }

(h) †8 511 922
(m) †8 540 903
(n) 8 543 250

8 511 109

(e) 6 035 177

(e) 6 035 178

(e) 6 035 176

L0=176 (a) 5 525 879
L0=182 (b) 5 529 727

†7 059 493
7 061 220

(f) 6 035 159

1081 210866

†1080 100856
1080 140856

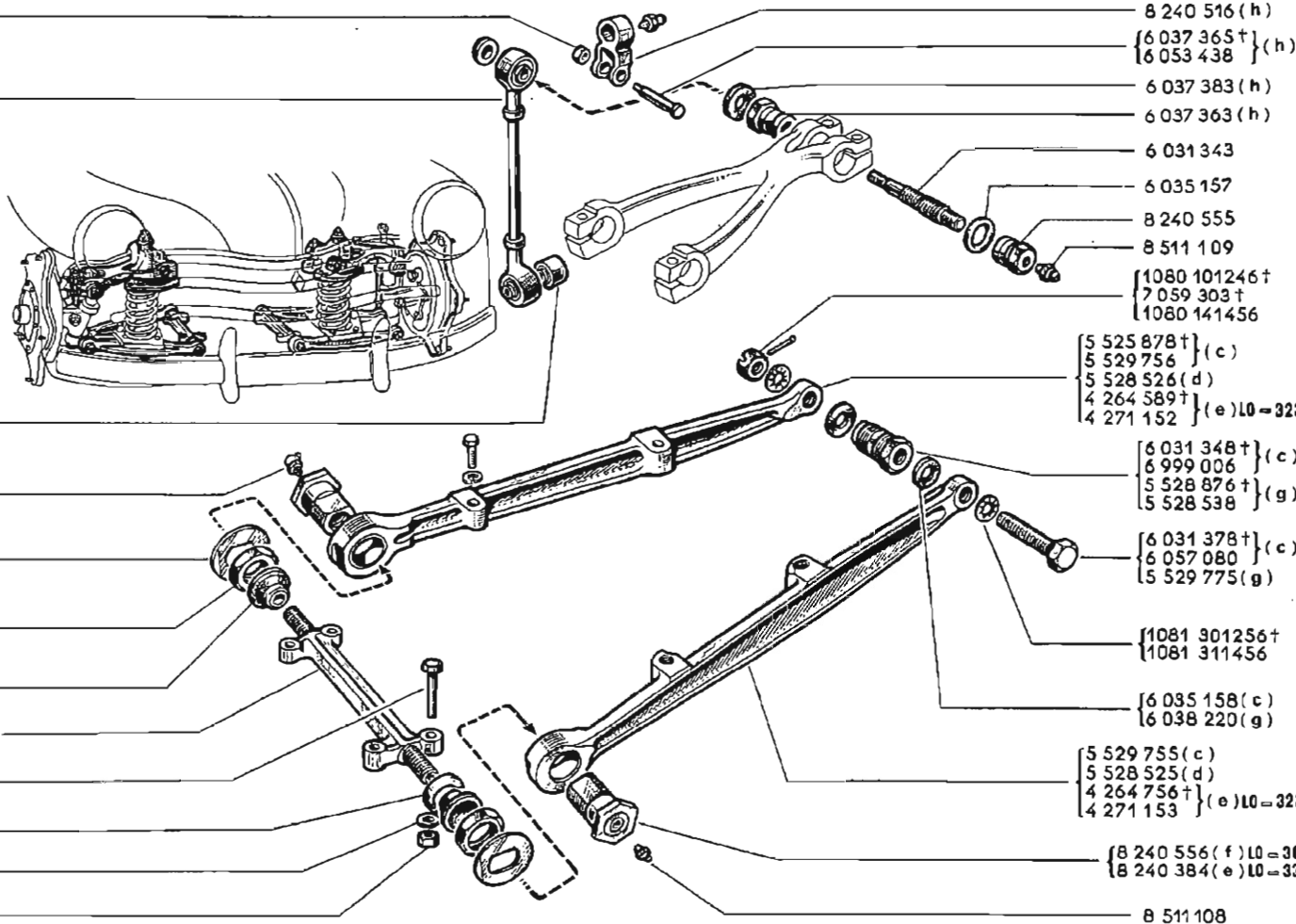

8 240 516 (h)

{ 6 037 365 †
6 053 438 } (h)

6 037 383 (h)

6 037 363 (h)

6 031 343

6 035 157

8 240 555

8 511 109

{ 1080 101246 †
7 059 303 †
1080 141456 }

{ 5 525 878 † } (c)
5 529 756
5 528 526 (d)
4 264 589 † } (e) L0=323
4 271 152

{ 6 031 348 † } (c)
6 999 006
5 528 876 † } (g)
5 528 538

{ 6 031 378 † } (c)
6 057 080 } (g)
5 529 775

{ 1081 301256 †
1081 311456 }

{ 6 035 158 (c)
6 038 220 (g) }

{ 5 529 755 (c)
5 528 525 (d)
4 264 756 † } (e) L0=323
4 271 153

{ 8 240 556 (f) L0=30
8 240 384 (e) L0=33 }

8 511 108

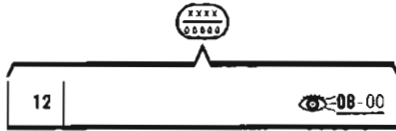

	n°...	⇒	n°...	↗	↘	!!!
(a)				12	12	9
(b)				12		
(c)	1 VEH		5325			
(d)	5326 VEH		...		12	
(e)				12		
(f)					12	
(g)	5326 VEH		...			
(h)	3491 CAR		...			
(j)	3491 CAR		9470			
(k)	9471 VEH		...			
(m)	1 VEH		880938			
(n)	880939 VEH		...			

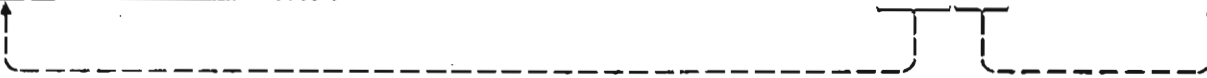

- (f) 1080 140856
- (f) { † 8 231 762
- 8 238 584
- 8 233 216
- (d) { † 7 059 462
- † 7 061 057
- 7 061 860
- (e) 6 050 300
- (d) 8 240 929
- (d) 7 060 298
- † 8 511 922
- † 8 540 903

- 1080 100856
- 1080 100856
- 8 511 109
- 1081 300856
- (b) 6 035 177

- (e) 6 050 576

- (b) 6 035 178

- (b) 6 035 176

- (a) 5 525 879
- (b) 5 529 727
- (a) 5 528 526
- (b) 4 271 152
- † 7 059 493
- 7 061 220

- 1081 210866

- 1080 100856

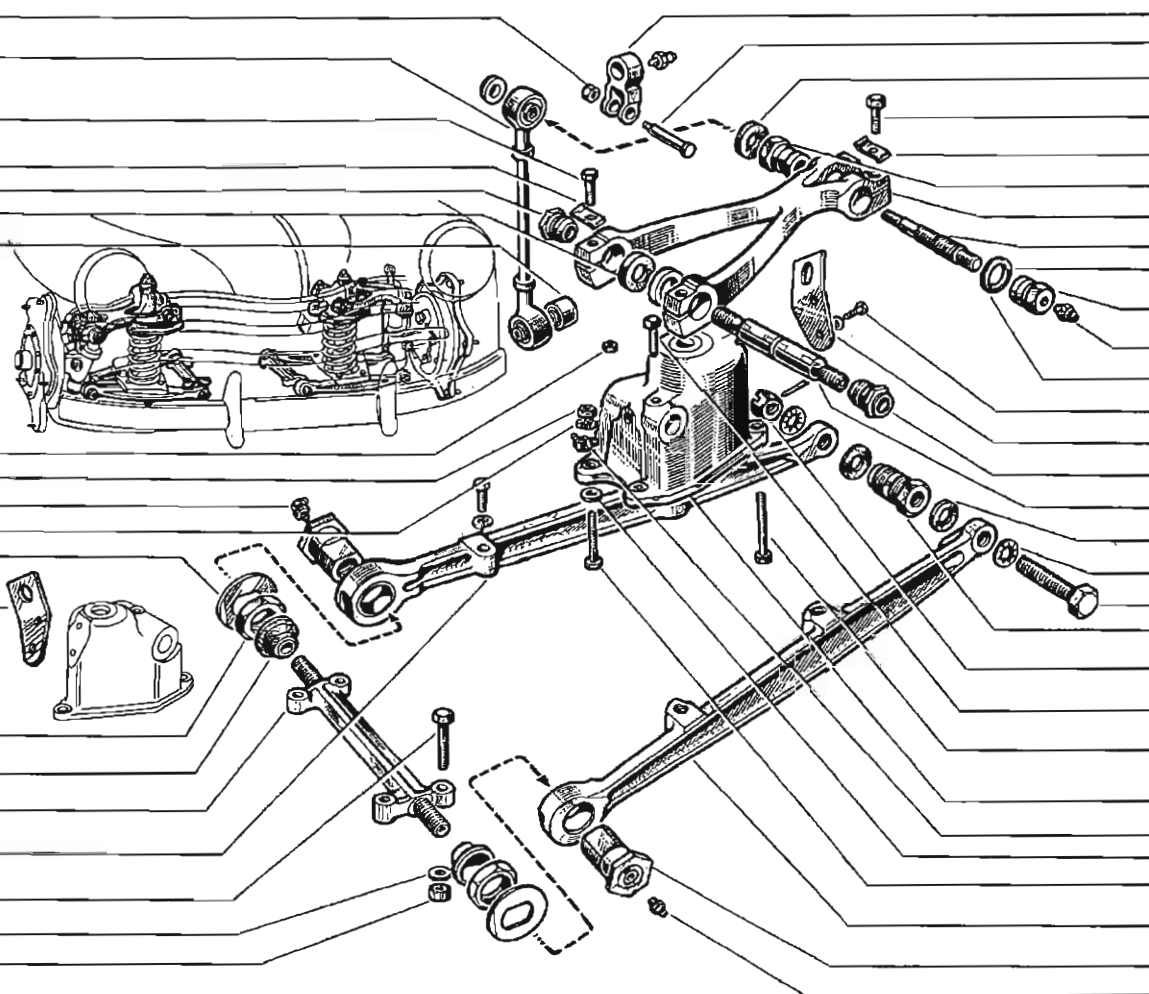

- 8 240 516 (g)
- { 6 037 365 †
- 6 053 438 } (f)
- 6 037 383 (g)
- { 7 059 462 †
- 7 061 057 † } (d)
- 7 061 860
- 6 050 300 (e)
- { 6 037 363 (f)
- 6 044 059 (e)
- 4 267 067 (d)
- { 6 031 343 (f)
- 5 536 755 (e)

- 8 240 555
- 8 511 109
- 6 035 157
- 1023 070126 (c)
- 6 050 575 (e)
- 8 240 929 (d)
- 5 532 441 (d)
- 6 038 220 (c)
- 1081 301256 †
- 1081 311456 (c)
- 5 529 775 (c)
- 5 528 538 (c)
- 1080 101246 †
- 7 059 303 †
- 1080 141456 (c)
- 6 042 400 (d)
- 7 059 831 †
- 7 060 297 †
- 7 062 381
- { 4 266 805 †
- 4 268 771 } (d)
- 8 511 280 (d)
- 7 059 834
- 7 059 987 †
- 7 062 380
- { 5 528 525 (a)
- 4 271 153 (b)
- { 8 240 556 (a)
- 8 240 384 (b)
- 8 511 108 (c)

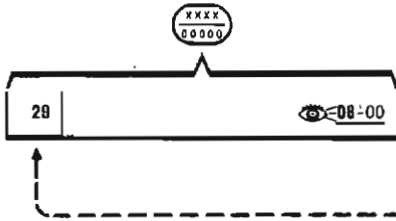

	n°...	n°...			!!!
(a)	1 VEH	1929			
(b)	1930 VEH	...			
(c)				29	
(d)	2525 VEH	...			
(e)	4241 VEH	...			
(f)	3704 VEH	4240			
(g)	1 VEH	4240			

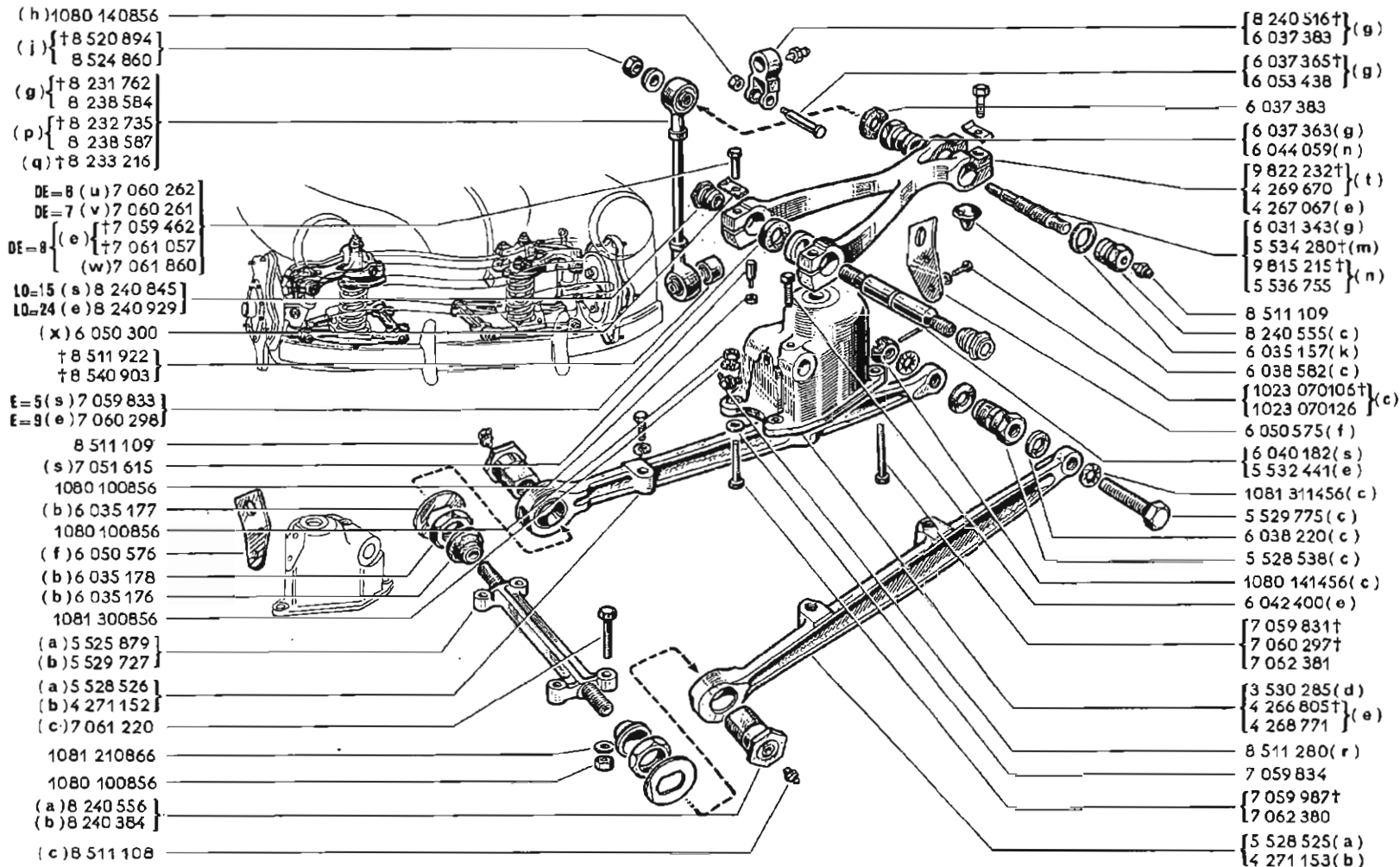

XXXX 00000	
1	08-00
2	08-00
9	08-00
29	08-00

	n°...	n°...	!!!
(a)	1 VEH	49921	
(b)	49922 VEH	...	29
(c)			29
(d)	1 VEH	69929	1
(e)	69930 VEH	...	2 29
(f)	352453 VEH	...	9 29
(g)	1 VEH	119138	
	119232 VEH	151131	
(h)	1 VEH	208988	
	209001 VEH	211017	
(i)	208989 VEH	209000	
	211018 VEH	...	
(k)	1 VEH	151131	
	151132 VEH	...	29
(m)	119139 VEH	119231	
(n)	119139 VEH	119231	
	151132 VEH	...	29
(p)	119139 VEH	119231	
	151132 VEH	154894	
(q)	154895 VEH	...	29
(r)	69930 VEH	...	1 2 29
(s)			1
(t)			1 10
(u)	1 VEH	26955	
(v)	26956 VEH	69929	
(w)	69930 VEH	...	
(x)	334235 VEH	...	29

!!!		
10	4	7060261 -4-



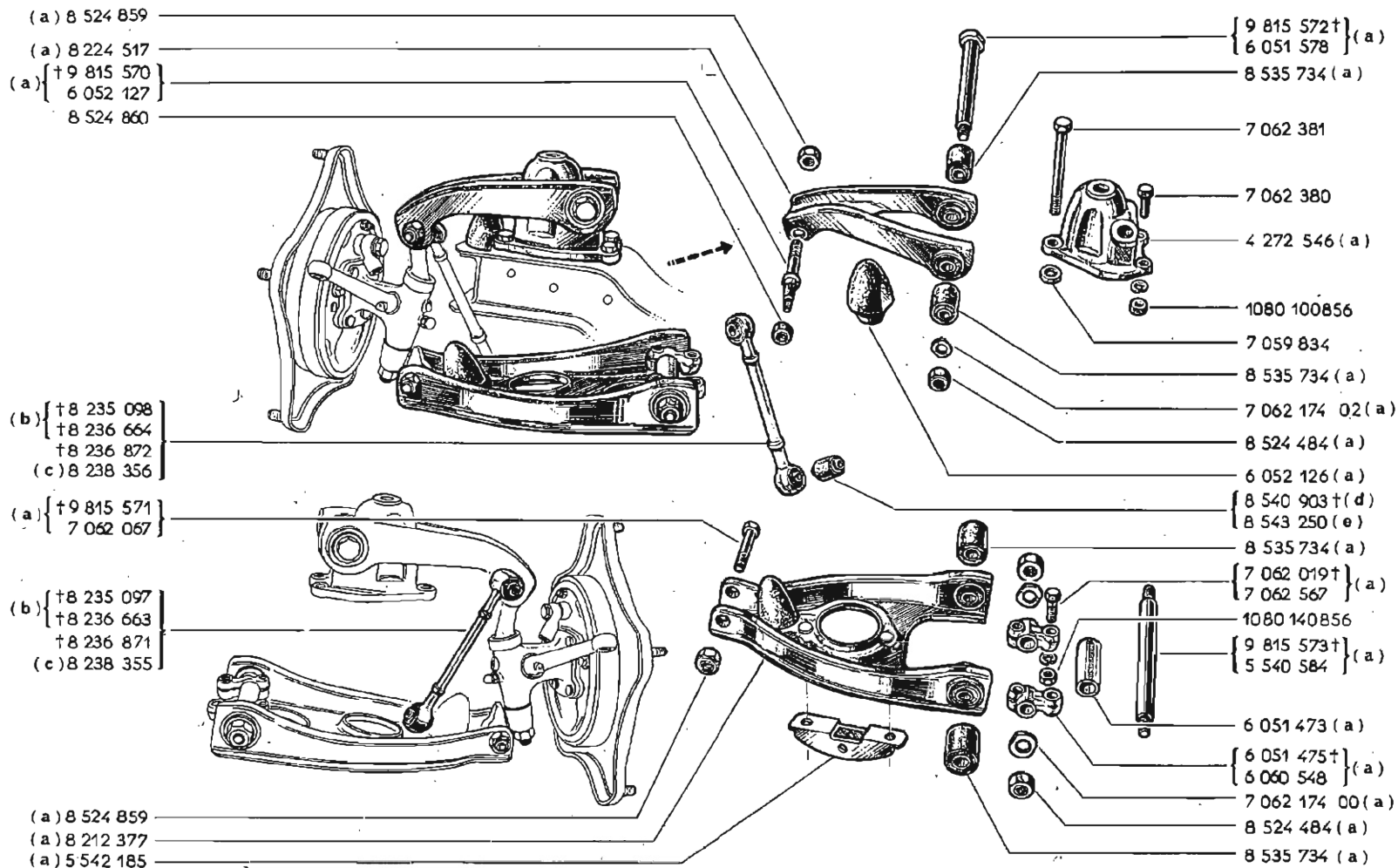

XXXX
00000

29

08-00

	n°...	→	n°...	⚡	⚡	!!!
(a)				29		
(b)	484679 VEH		758828	29		
(c)	126221 TAV		...			
(d)	484679 VEH		880938			
(e)	880939 VEH		...			

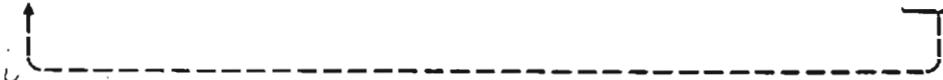

{ (R. 1080) (R. 2070) (d) }
{ (R. 1082) (e) }
{ (R. 2071) (f) }

8 541 766

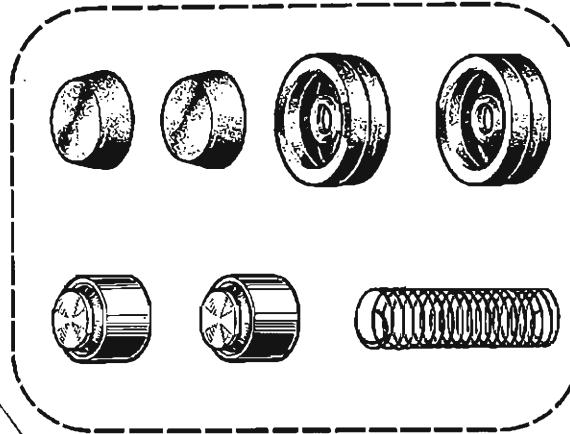

8 541 766

{ (d) (R. 1080) (R. 2070) }
{ (e) (R. 1082) }
{ (f) (R. 2071) }

{ (R. 1080) (R. 2070) (a) }
{ (R. 1082) (b) }
{ (R. 2071) (c) }

8 541 483

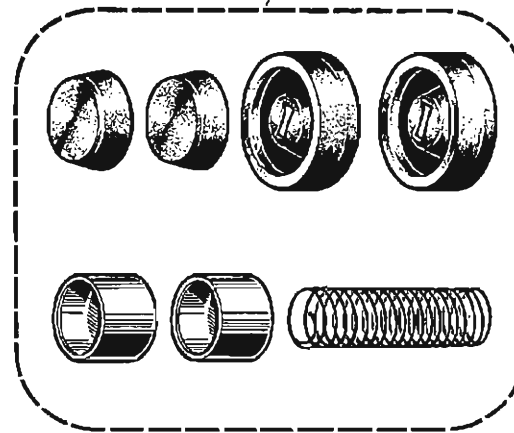
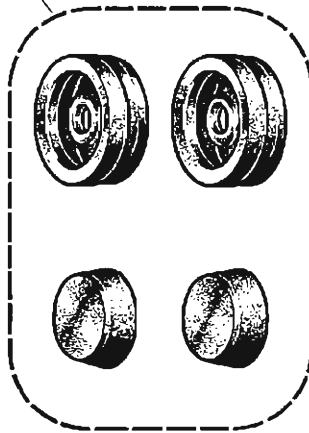
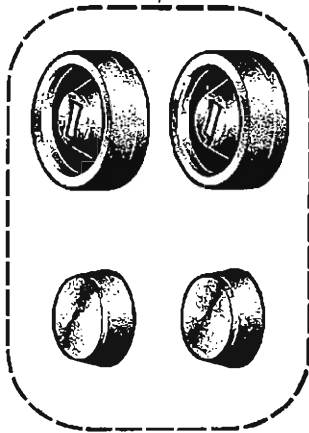

8 541 482

{ (a) (R. 1080) (R. 2070) }
{ (b) (R. 1082) }
{ (c) (R. 2071) }

<div style="border: 1px solid black; border-radius: 50%; padding: 2px; display: inline-block;"> XXXX 00000 </div>	
6	08-00
7	08-00

	<div style="border: 1px solid black; border-radius: 50%; padding: 2px; display: inline-block;"> XXXX 00000 </div>		<div style="border: 1px solid black; border-radius: 50%; padding: 2px; display: inline-block;"> XXXX 00000 </div>			
(a)					8 7	
(b)	1 VEH		32644			
	34445 VEH		34507			
(c)	1 VEH		1470			
(d)					8 7	
(e)	32645 VEH		34444			
	34508 VEH		...			
(f)	1471 VEH		...			



8 535 819

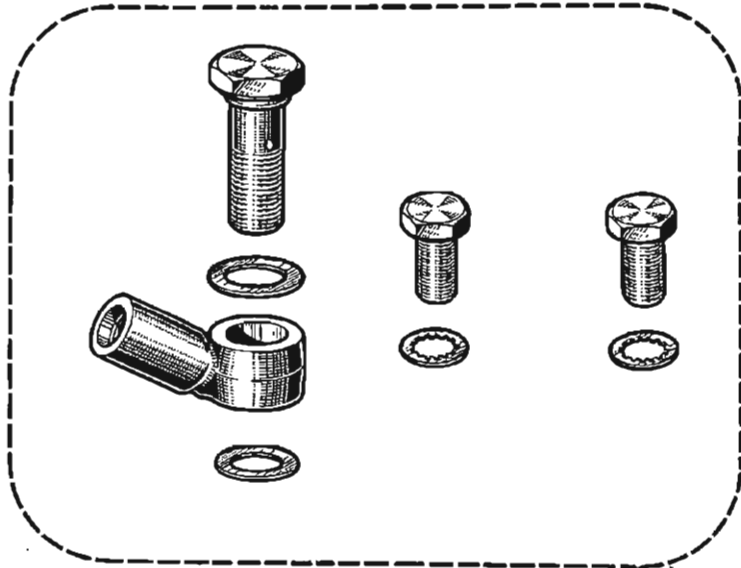
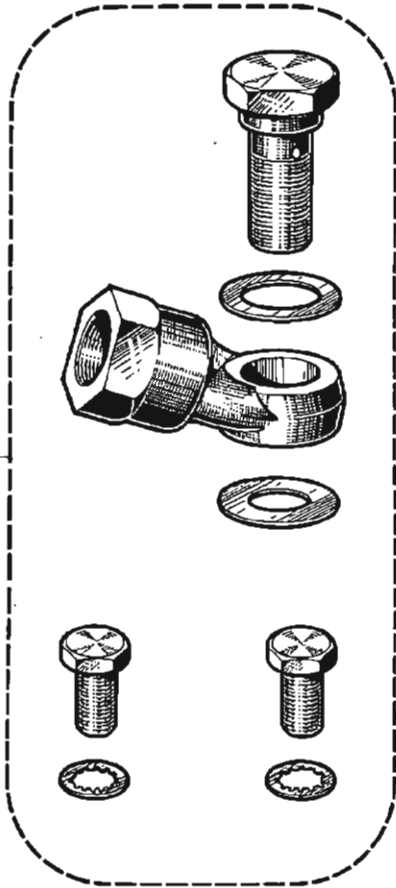

8 536 088 (R. 1082) (R. 2071)

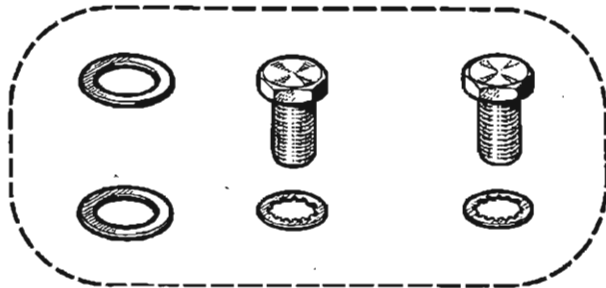

8 541 112 (R. 1082)

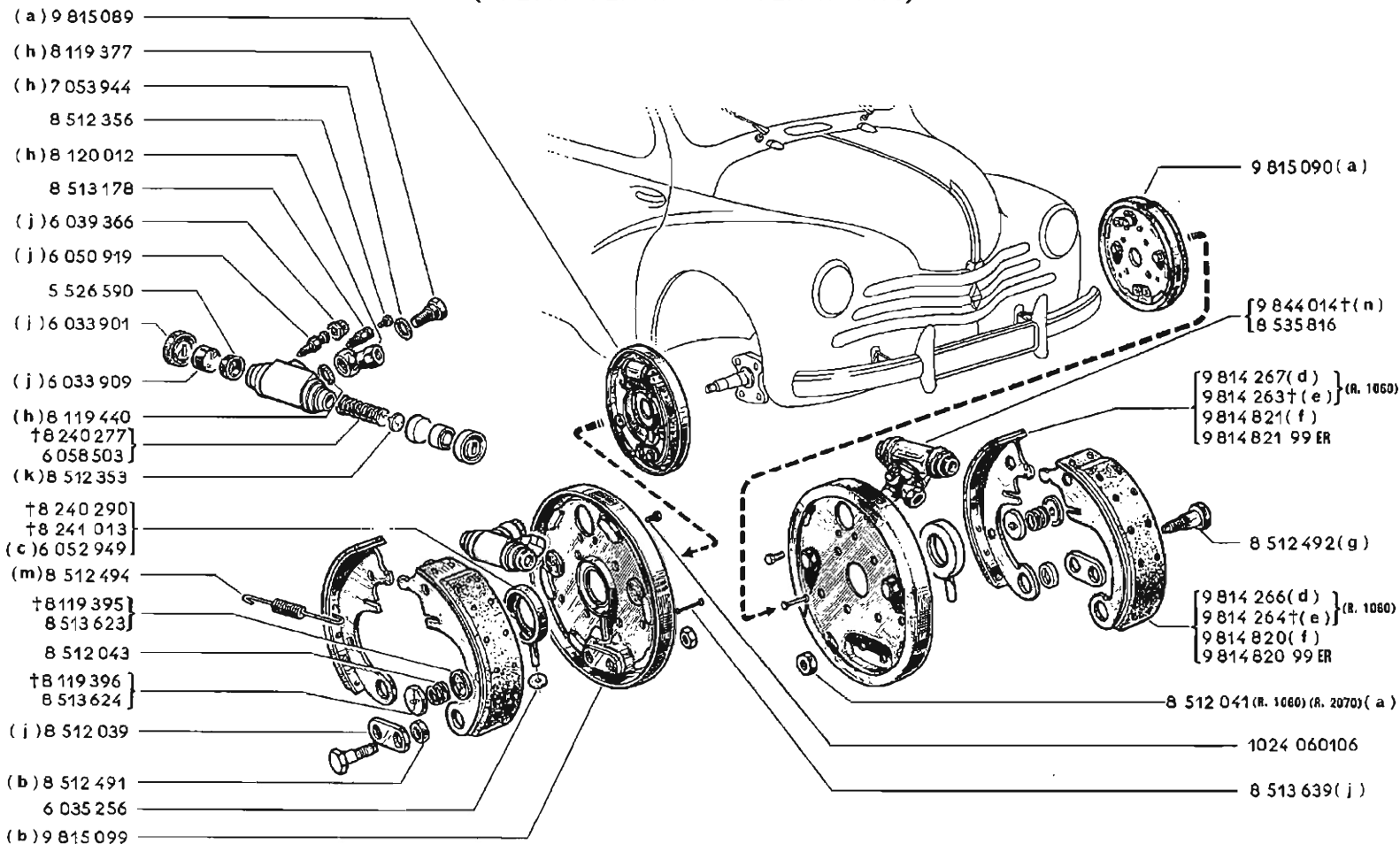

	n°...	n°...	!!!
(a)			8 7
(b) R.1060	301 VEH	...	8 7
R.1062			
R.2071			
R.2070			8 7
(c)	173651 TAV	...	
(d)	1 VEH	300	11
(e)	301 VEH	...	8 7 11
(f) R.1060	301 VEH	...	8 7 11
R.1062			11
R.2071			11
R.2070			8 7 11
(g) R.1060	301 VEH	...	8 7
R.1062			
R.2071			
R.2070			8 7
(h) R.1060			
R.2070			
R.2071			
R.1062		4	3
(j) R.1060			6 7 6 7
R.2070			
R.1062			
R.2071			
(k) R.1060	1 VEH	56499	94
R.2070	1 VEH	6091	94
(m) R.1060	301 VEH	...	
R.1062			
R.2070			8 7 93
R.2071			8 7 93
(n) R.1060			8 7 93
R.2070			
R.1062			
R.2071			

XXXX
00000

3	08-00
4	08-00
6	08-00
7	08-00

!!!

11	06-00
93	06-00
94	06-00



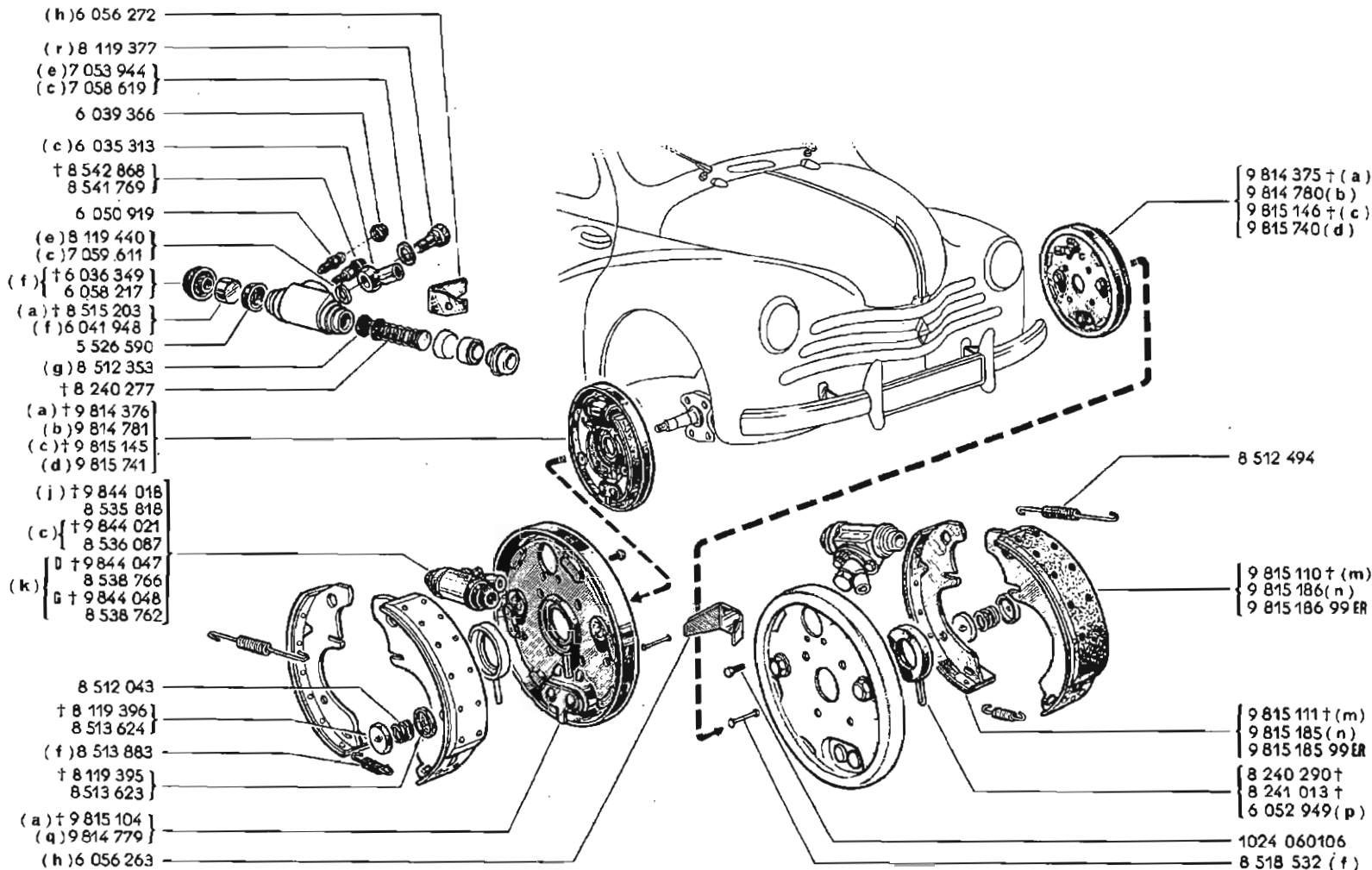

		XXXX 00000	!!!
n°...	n°...		
(a) R.1080		6	
R.2070		7	
		6	
		7	
(b) R.1060		6	
R.2070		7	
		6	
		7	
R.1082	32645 VEH	252105	3
R.2071	1471 VEH	4240	
(c) R.1062	252106 VEH	634187	3 4
			35 34
R.2071	4241 VEH	...	
(d) R.1062	634188 VEH	...	34 35 234
(e) R.1060			
R.2070			
R.1062	32645 VEH	252105	4 3
R.2071	1471 VEH	4240	
(f) R.1060		6	
R.2070		7	
		6	
		7	
R.1062			
R.2071			
(g) R.1060	1 VEH	56499	94
R.2070	1 VEH	6991	94
(h) R.1062	566721 VEH	634187	35 34
(j) R.1060		8	93
R.2070		7	
		6	93
		7	
R.1062	32645 VEH	252105	4 3
R.2071	1 VEH	4240	
(k) R.1062	634188 VEH	...	34 35
(m) R.1060		6	11
R.2070		7	
		6	11
		7	
(n) R.1060		6	11
R.2070		7	
		8	11
		7	
R.1062			11
R.2071			11
(p)	173851 TAV	...	
(q)		6	
		7	
(r) R.1060			
R.2070			
R.1082	32645 VEH	252105	4 3
R.2071	1 VEH	4240	

		XXXX 00000
3		08-00
4		08-00
6		08-00
7		08-00
34		08-00
35		08-00

		!!!
11		06-00
93		08-00
94		08-00
234		08-00

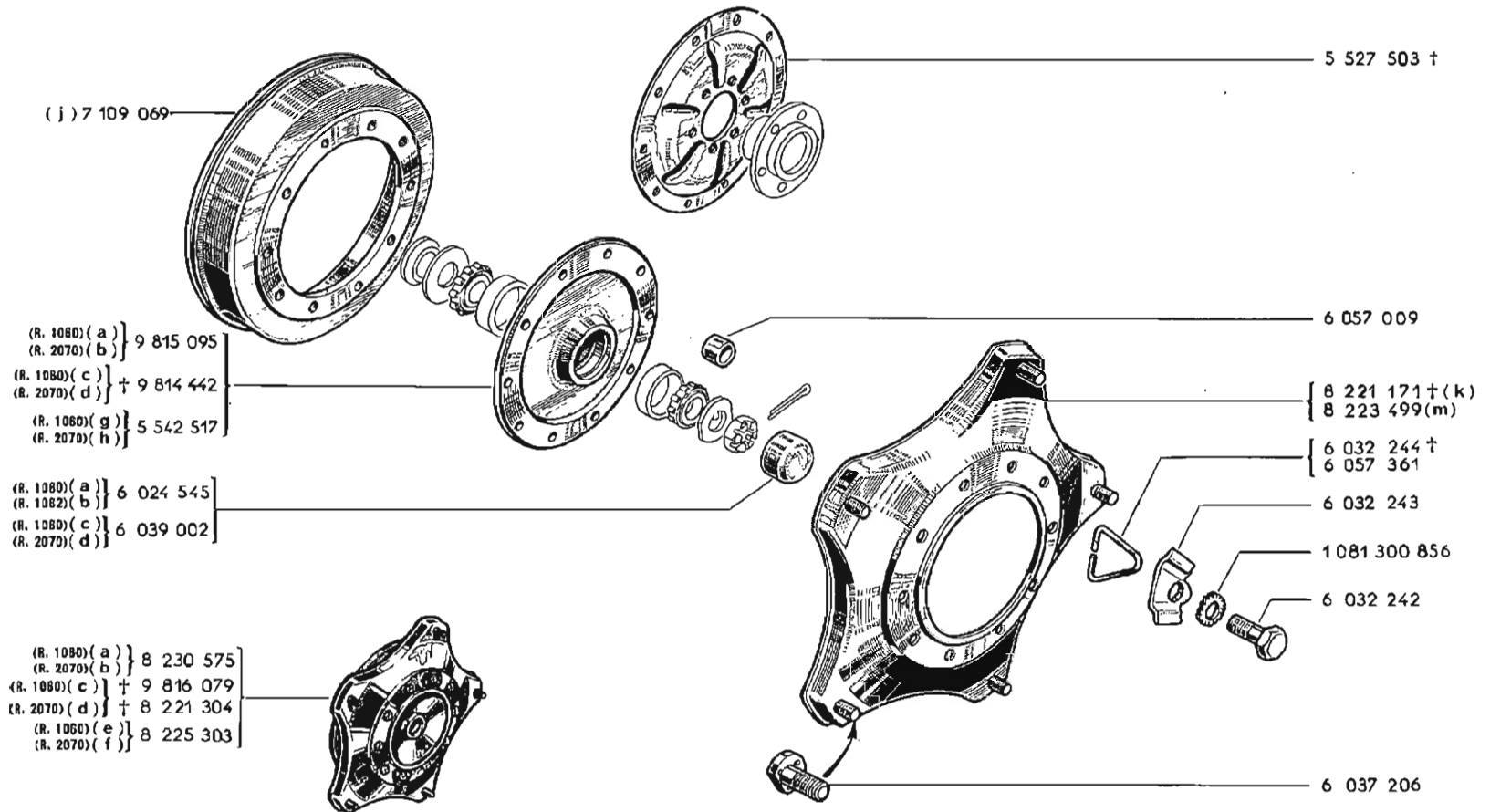

11	08-00
----	-------

	n°...	n°...		!!!
(a)	1 VEH	107931	11	
(b)	1 VEH	10036	11	
(c)	107932 VEH	...	11	
(d)	10037 VEH	...	11	
(e)	107932 VEH	...	11	193
(f)	10037 VEH	...	11	193
(g)	107932 VEH	...		201
(h)	10037 VEH	...		201
(i)				12
(k)				194
(m)				196

12		06-00
193	⚖	6054434 - 1-
194	⚖	8057009 - 10-
196	⚖	6057009 - 10-
201	⚖	8057009 - 10- 6054434 - 1-



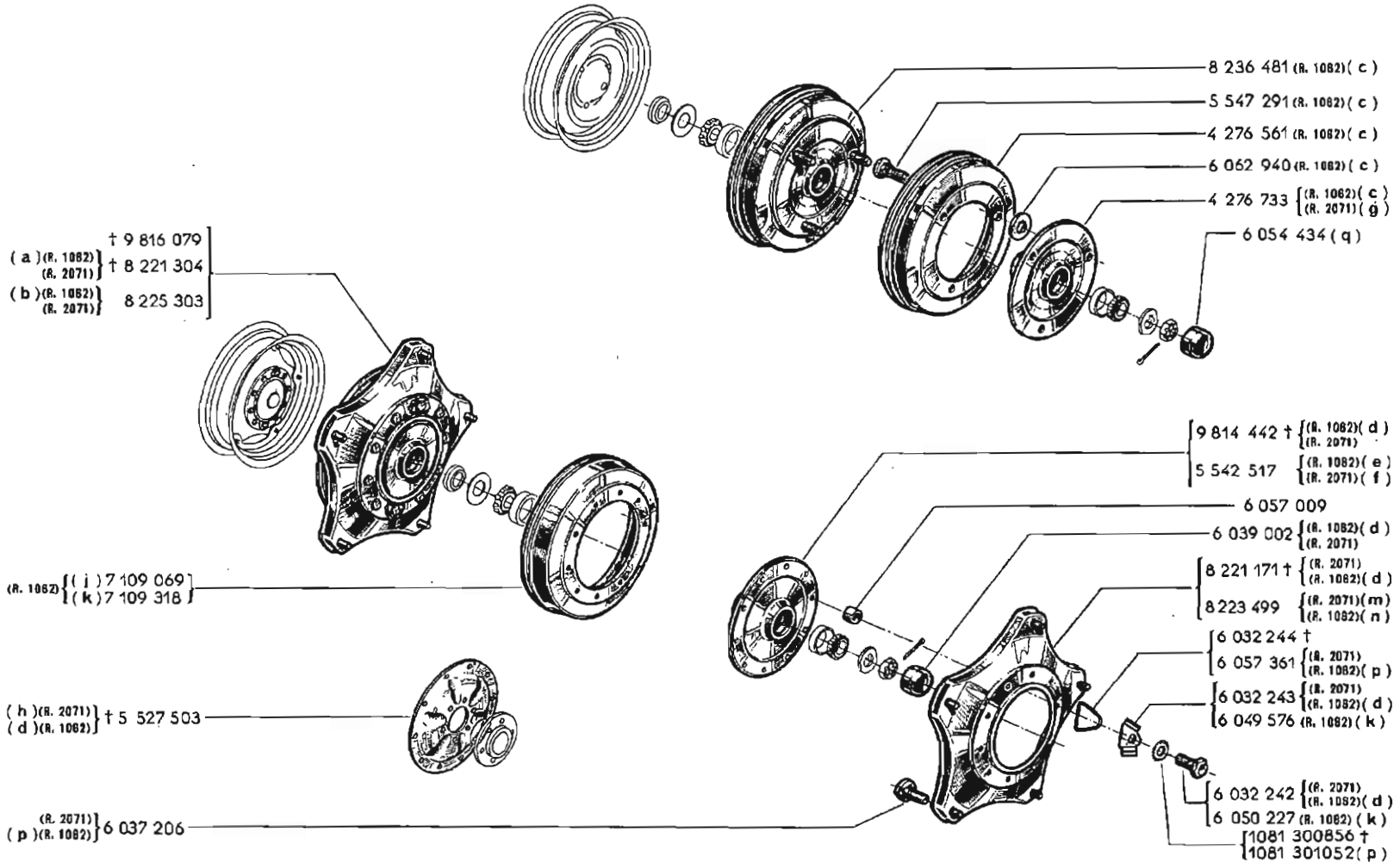

	n°...	↔	n°...	⚡	⚡	!!!
(a)	1 TAV		151847			
(b)	1 VEH		748117		83	193
(c)	748118 VEH		...	83		
(d)	1 TAV		151847			
	152766 TAV		153565			
(e)	1 VEH		748117		83	201
(f)	1 VEH		4240			201
(g)	4241 VEH		...			
(h)				10		
(j)	1 TAV		151847			12
	152766 TAV		153565			
(k)	151848 TAV		152765			
	153566 TAV		...			
	1 VEH		748117		83	
(m)						194 198
(n)	1 VEH		748117			194
(p)	-1 VEH		748117		83	
(q)	151148 TAV		152765			
	153566 TAV		...			

XXXX
00000

10	08-00
83	08-00

!!!

12		06-00
193		6054434 -1-
194		6057009 -10-
198		6057009 -10-
201		6057009 -10- 6054434 -1-



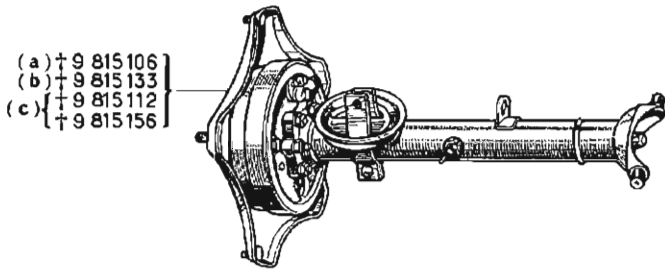

- (a) † 9 815 106
- (b) † 9 815 133
- (c) † 9 815 112
- † 9 815 156

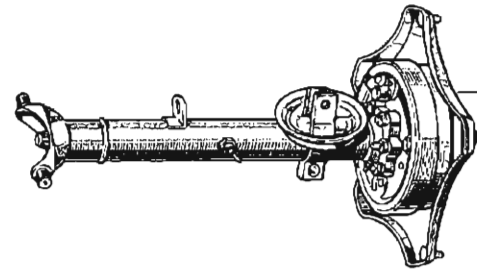

- 9 815 105 † (a)
- 9 815 134 † (b)
- 9 815 113 † (c)
- 9 815 155 †

<div style="border: 1px solid black; border-radius: 50%; padding: 2px; display: inline-block;"> XXXX 00000 </div>	
6	08-00
7	08-00

	<div style="border: 1px solid black; border-radius: 50%; padding: 2px; display: inline-block;"> XXXX 00000 </div>		!!!
n°...	⇨	n°...	!!!
(a)		8	96
(b)		7	96
(c)		6 7	96

<div style="border: 1px solid black; border-radius: 50%; padding: 2px; display: inline-block;"> !!! </div>	
96	8031266 - 7 -



(R. 1082) (a) } † 9 815 133
 (R. 2071) (b) }
 (R. 1082) (c) } † 9 815 156
 (R. 2071) (d) }

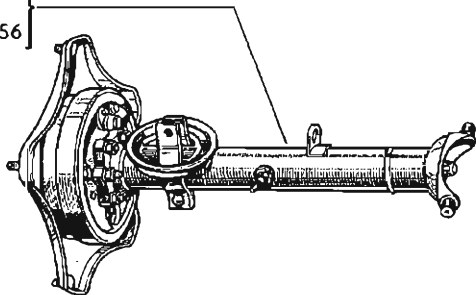

9 815 134 † { (a) (R. 1082)
 (b) (R. 2071)
 9 815 155 † { (c) (R. 1082)
 (d) (R. 2071)

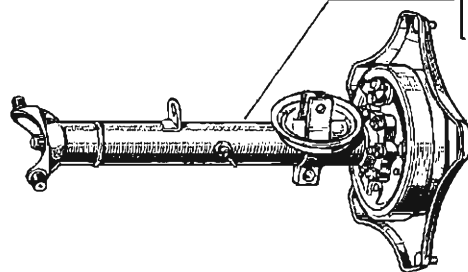

(R. 1082) (e) } † 9 813 822
 (R. 2071) (f) }
 (R. 1082) (g) } † 9 815 205
 (R. 1082) (h) } † 9 815 203
 (R. 2071) (j) }
 (R. 1082) (k) } † 9 816 366
 (R. 2071) (j) }

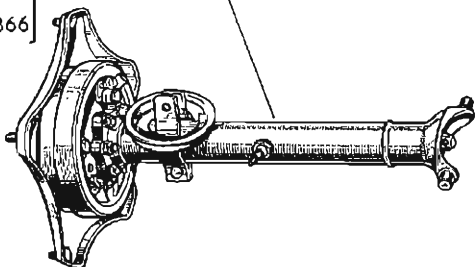

9 813 821 † { (e) (R. 1082)
 (f) (R. 2071)
 9 815 206 † (g) (R. 1082)
 9 815 204 † { (h) (R. 1082)
 (j) (R. 2071)
 9 816 367 † { (k) (R. 1082)
 (j) (R. 2071)

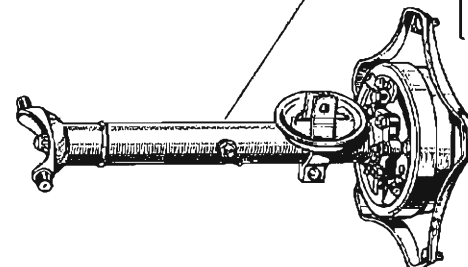

XXXX
00000

1	08-00
2	08-00
3	08-00
4	08-00
34	08-00
35	08-00
47	08-00
83	08-00

XXXX
00000

!!!

	n°...	n°...	↙	↘	!!!
(a)	32645 VEH 34508 VEH	34444 69929	1 2		
(b)	1471 VEH	2524			
(c)	1 VEH 34445 VEH	32644 34507			
(d)	1 VEH	1470			
(e)	69930 VEH	194782	2 47		14
(f)	2525 VEH	4240			14
(g)	194783 VEH	252105	4 47	3	14 158
(h)	252106 VEH	634187	35	4 34	
(j)	4241 VEH	...			
(k)	252106 VEH	748117	4 83		189

!!!

14	06-00
158	06-00
189	8236174 - 1- 7062407 - 1-



43.05



A P.R. 68'



(R. 1060) (R. 2070)

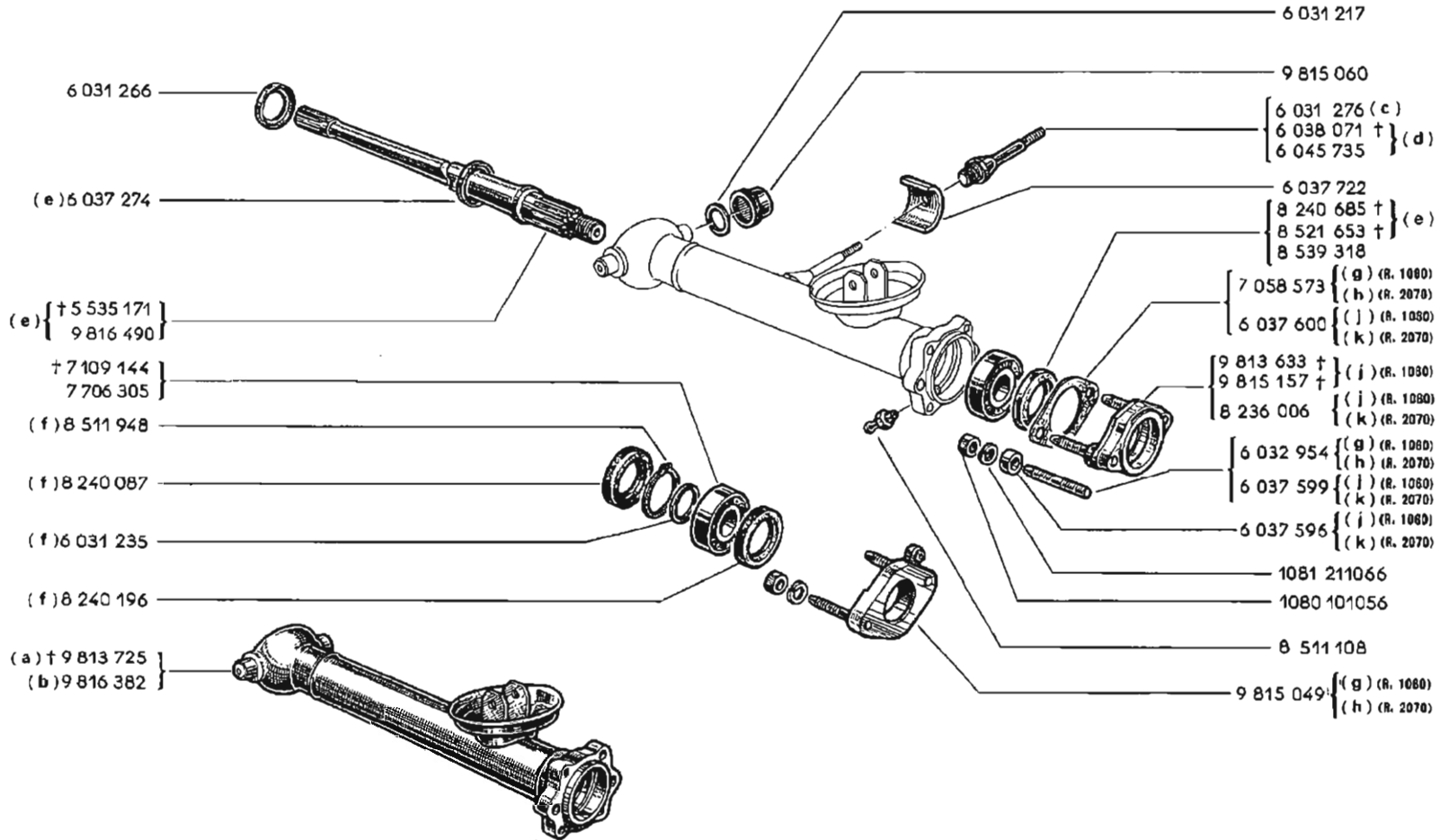

43.05

A P.R. 685



8	 08-00
10	 08-00

	n°...	n°...			
(a)					13
(b)					13 195
(c)	1 VEH	30000			
(d)	30001 VEH	...			15
(e)				10	
(f)				8	
(g)	1 VEH	71794			
(h)	1 VEH	8678			
(j)	71795 VEH	...			
(k)	8679 VEH	...			

13	 06-00
15	 06-00
185	 9818329 -2- 8049036 -2-



43.06

A P.R. 685

(R. 1062) (R. 2071)

43.06

A P.R. 685

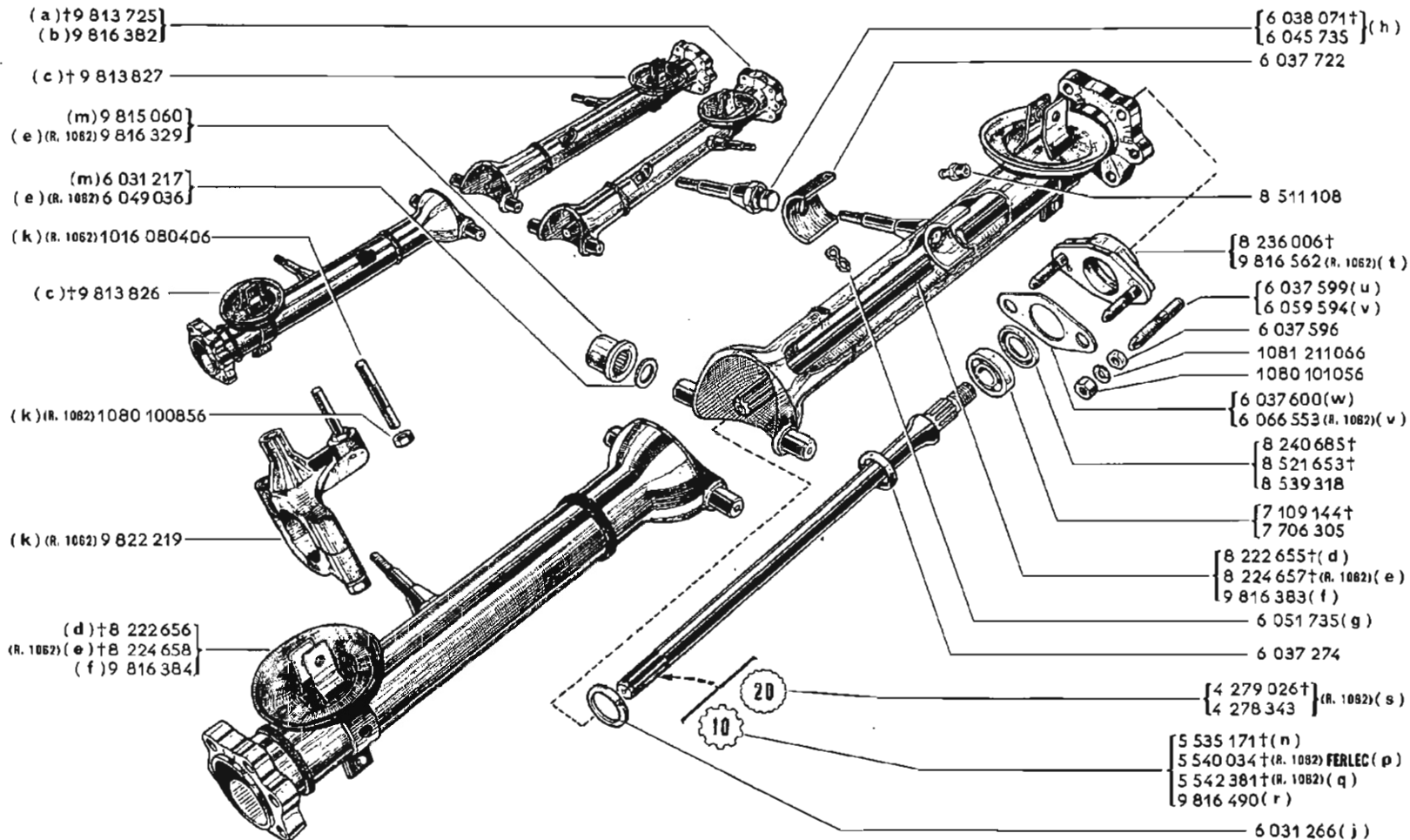

1	08-00
2	08-00
3	08-00
4	08-00
5	08-00
10	08-00
79	08-00
86	08-00
87	08-00

	n°...	→	n°...	↘	↙	!!!
(a) R.1062	1 VEH		69929	2		13
R.2071	1 VEH		2524			13
(b) R.1062	1 VEH		69929	2		13
R.2071	1 VEH		2524			195
						13
						185
(c) R.1062	69930 VEH		252105	4	2	14
R.2071	2525 VEH		4240		3	14
(d) R.1062	252106 VEH		612100	3	4	
R.1062	613905 VEH		613920	79		
R.2071	4241 VEH		...			
(e)	612101 VEH		613900		79	
	613921 VEH		...			
(f) R.1062	69930 VEH		...	2		13
R.2071	2525 VEH		...			195
						202
(g) R.1062	341820 VEH	TAR	4151			
R.2071	4241 VEH		...			
(h)						15
(i)	1 BP		221484		5	
(k)				1		
(m) R.2071						
R.1062	1 VEH		612100	79		
R.1062	613901 VEH		613920			
(n) R.2071				10		
R.1062	1 TAR		34141			
(p)	1 TAR		34141			
(q)				86		
(r) R.2071						
R.1062	34142 TAR		...	86		
R.1062	1 VEH		841460	86		
				87		
(s)	841461 VEH		...	86		
				87		
(t)	877488 VEH		...			266
(u)	1 VEH		877487			
(v)	877488 VEH		...			
(w) R.1062	1 VEH		877487			
R.2071						

13	06-00
14	06-00
15	06-00
195	8816329 -2- 6049036 -2-
202	9808824 -1-
266	08-00

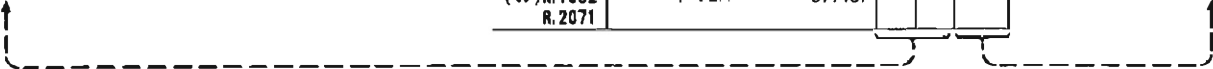

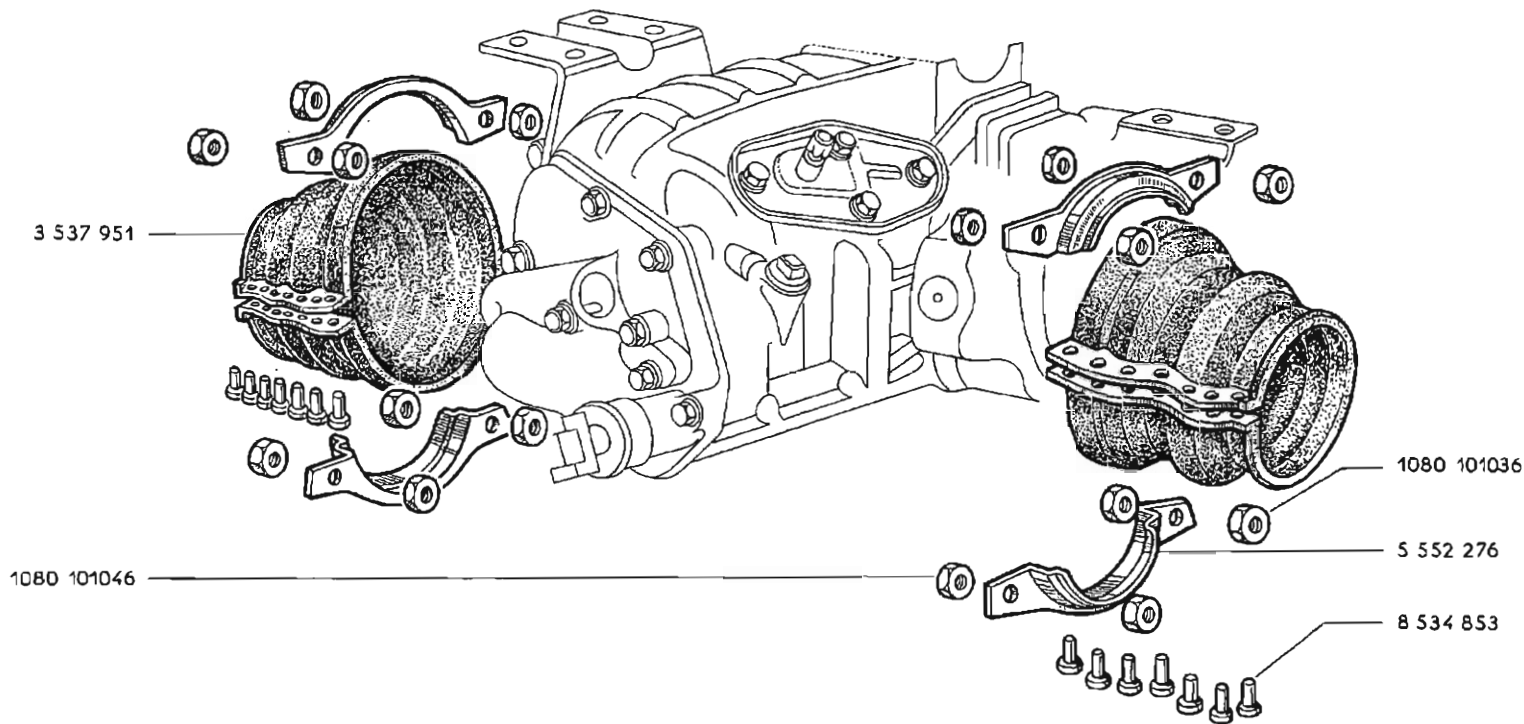

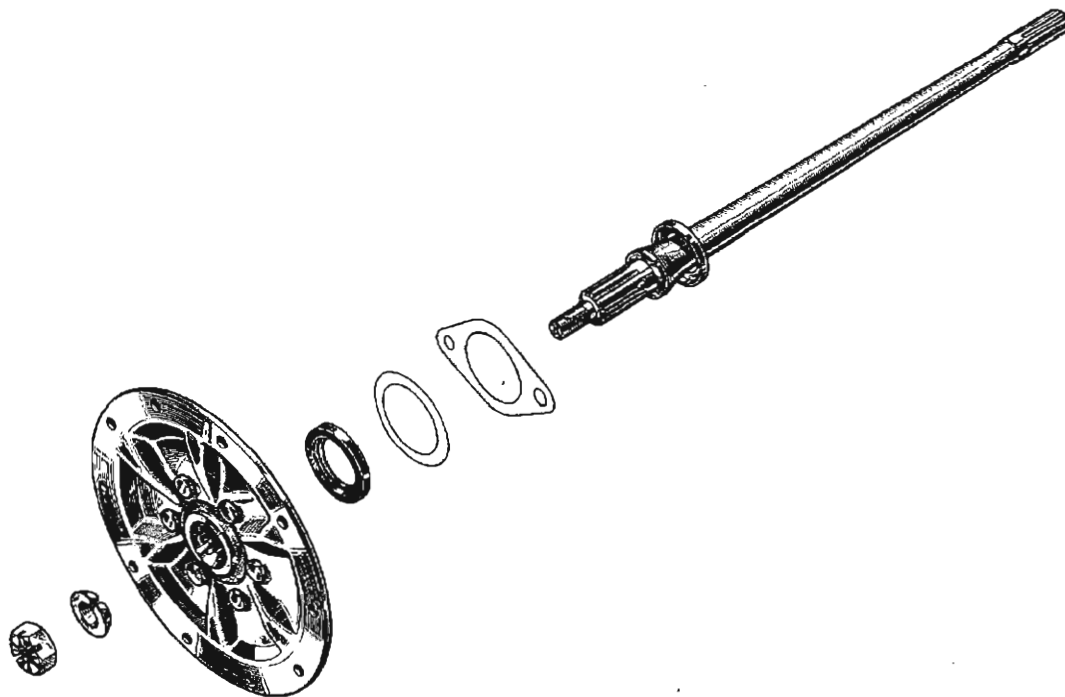





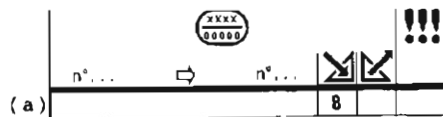
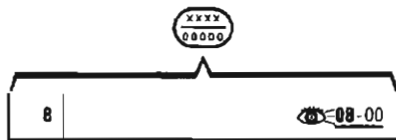

5 530 713 †
9 813 974 †(a)
9 816 449 †(a)

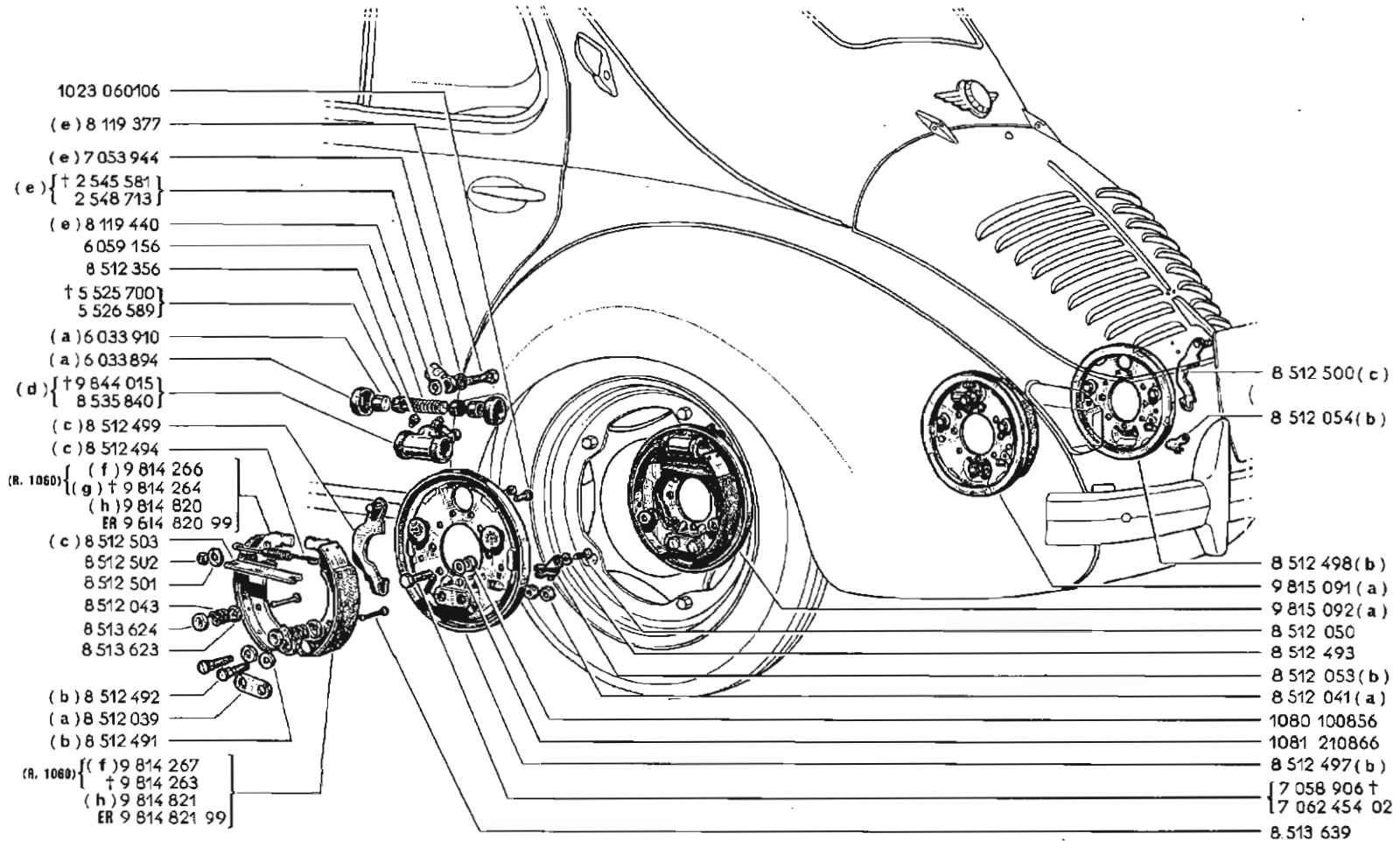



(R. 1060) (R. 2070)

(R. 1062)





<div style="text-align: center;">  </div>	
3	
4	
6	
7	

	n°...		n°...			
(a) R.1060						6
R.2070						7
R.1062						6
R.2071						7
(b) R.1060	301 VEH	...				6
R.1062						7
R.2071						6
R.2070						7
(c) R.1060	301 VEH	...				
R.1062						
R.2070						
R.2071						
(d) R.1060						6
R.2070						7
R.1062						93
R.2071						93
(e) R.1060						
R.2070						
R.1062				4	3	
R.2071						
(f)	1 VEH	300				11
(g)	301 VEH	...				6
						7
(h) R.1060	301 VEH	...				6
R.1062						7
R.2071						11
R.2070						11
						6
						7

<div style="text-align: center;">  </div>	
11	
93	

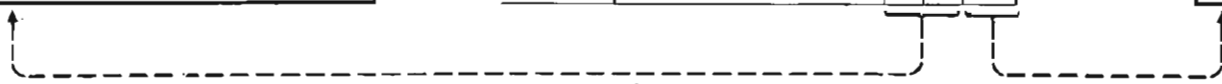

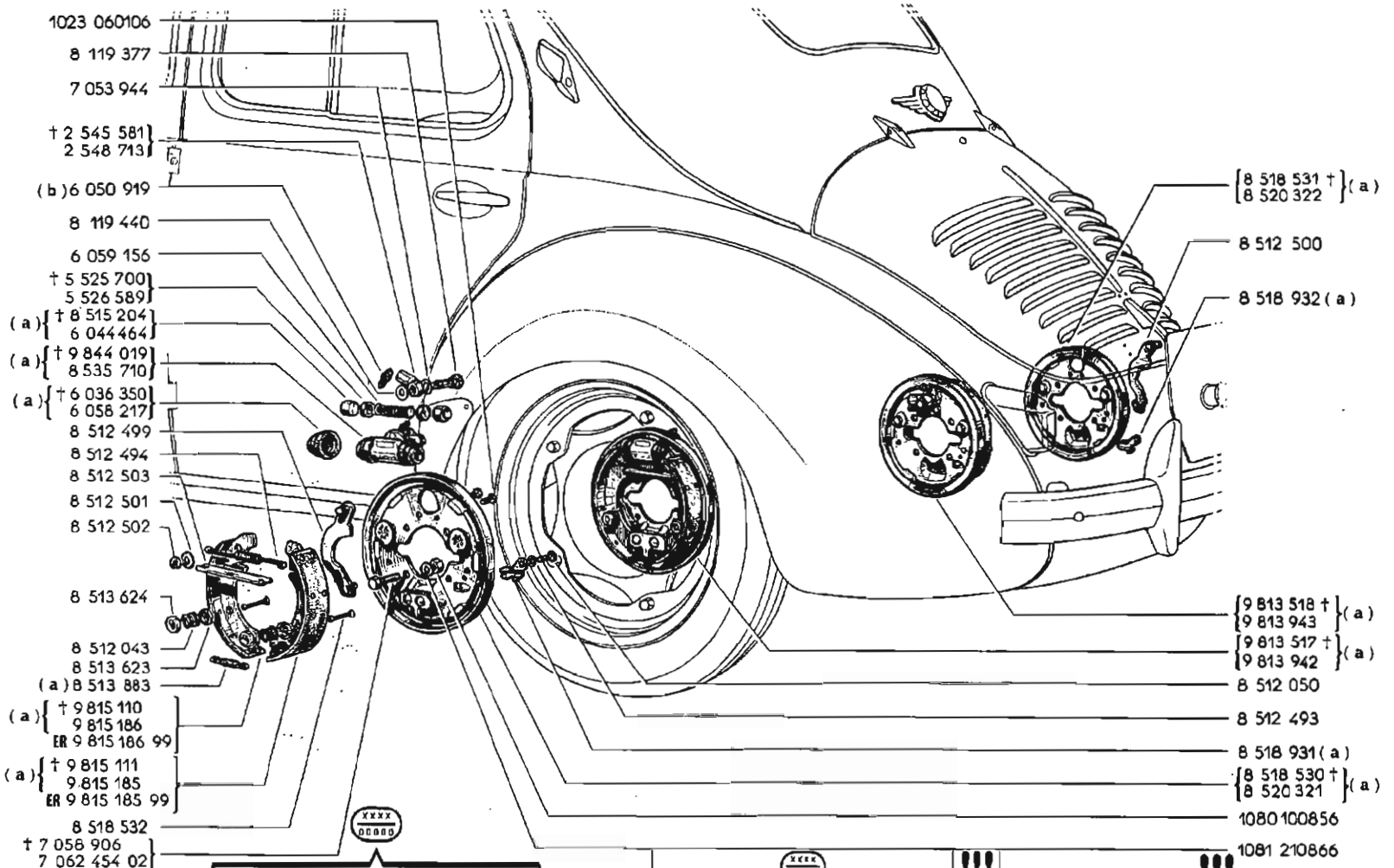

6	08-00
7	08-00

(a)	n°...	n°...	6
(b)			7
			97

97		8039388 -1-
----	--	-------------

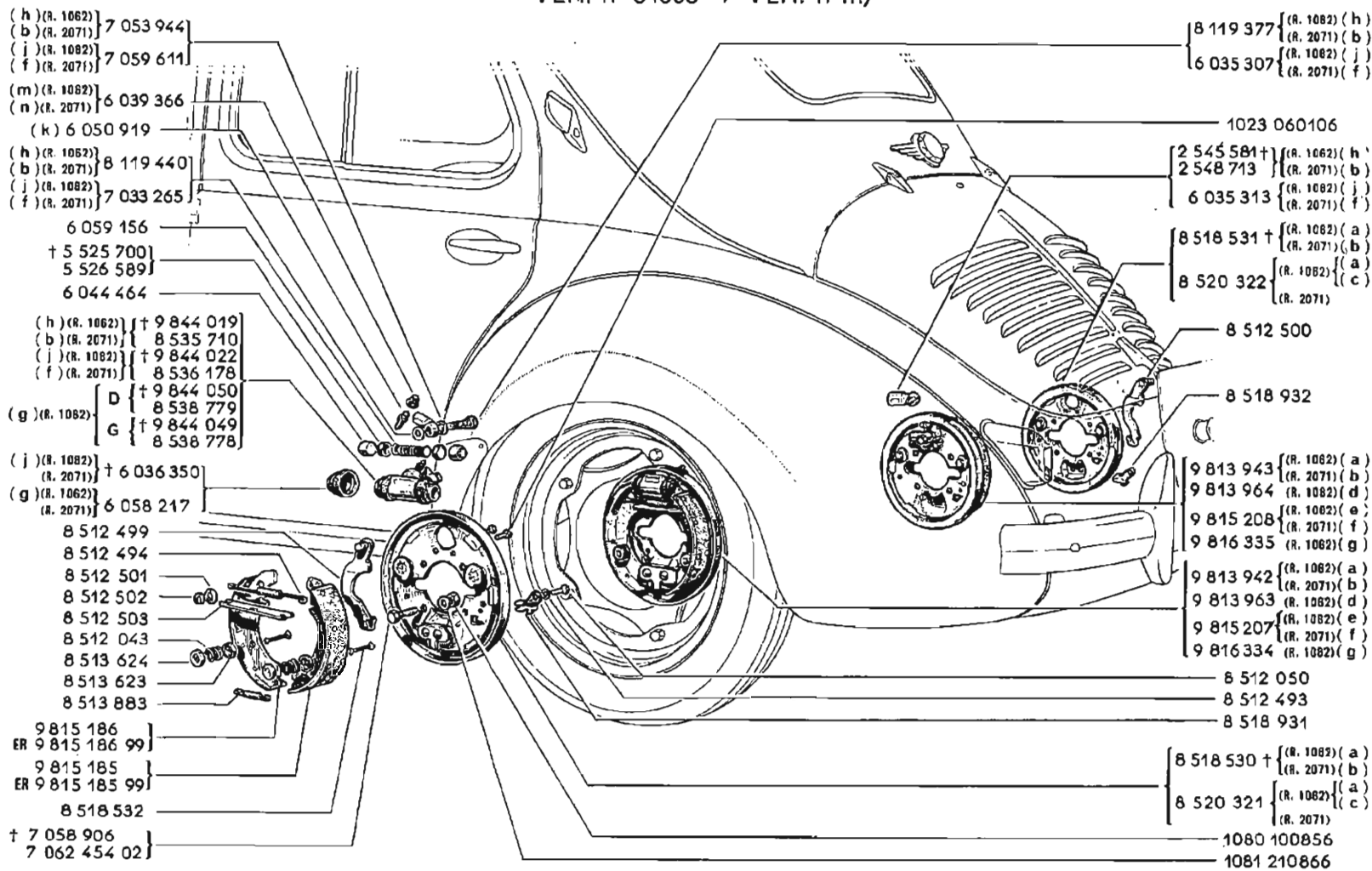

XXXX
00000

3	08-00
4	08-00
34	08-00
35	08-00
47	08-00

	n°...	n°...			!!!
(a)	32645 VEH	194782		47	
(b)	1471 VEH	4240			
(c)	194783 VEH	...	47		
(d)	194783 VEH	252105	4	3	158
			47		
(e)	252106 VEH	634187	35	4	
				34	
(f)	4241 VEH	...			
(g)	634188 VEH	...	34	35	
(h)	32645 VEH	252105	4	3	
(j)	252106 VEH	634187	3	4	
			35	34	
(k)					87
(m)	81350 VEH	...			
(n)	2800 VEH	...			

!!!

97		6039368 -1-
158		06-00



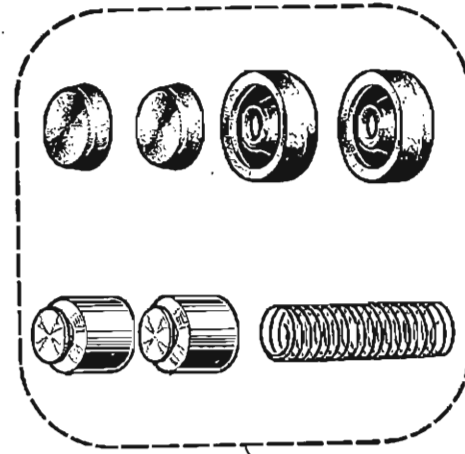
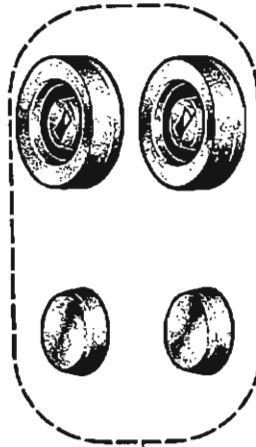
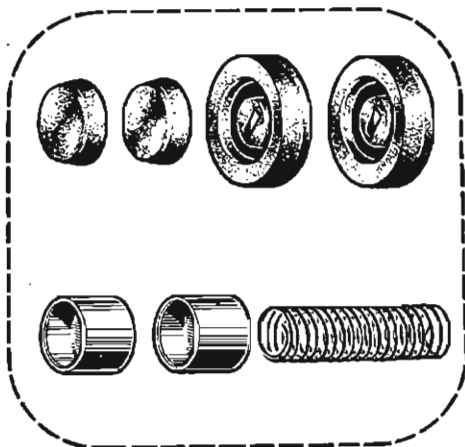

(R. 1060) (R. 2070) (a)
(R. 1062) (R. 2071) } 8 541 500

(R. 1062) (b) 8 541 765

(R. 1060) (R. 2070) (c)
(R. 1062) (d) } 8 541 499
(R. 2071)

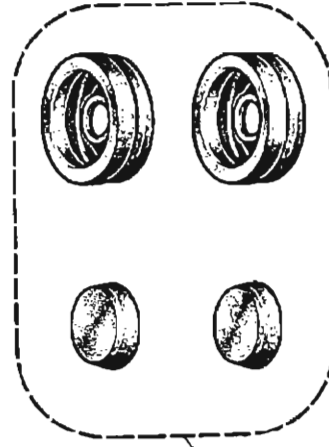
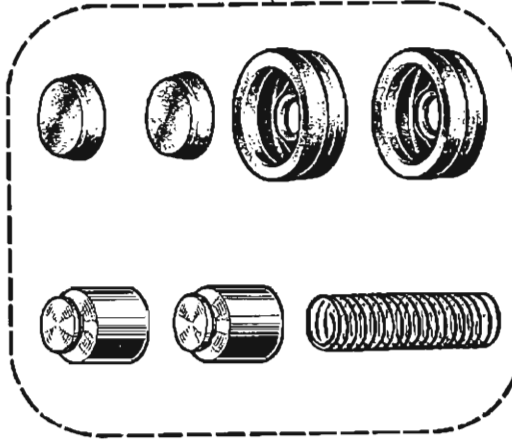
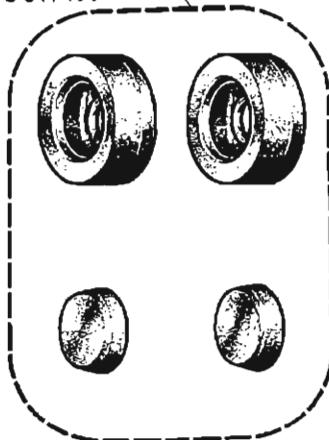

8 541 498 { (c) (R. 1060) (R. 2070)
(d) (R. 1062)
(R. 2071)

8 541 501 (a)





8 541 767 (b) (R. 1062)

XXXX
00000

6	 08-00
7	 08-00

XXXX
00000

D°... ⇨ n°...   !!!

(a)				6 7
(b)	634188 VEH	...		
(c)			6 7	
(d)	1 VEH	634187		

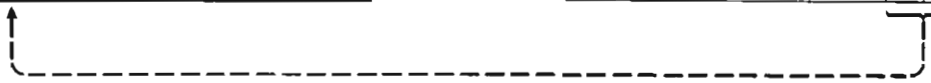

8 535 795

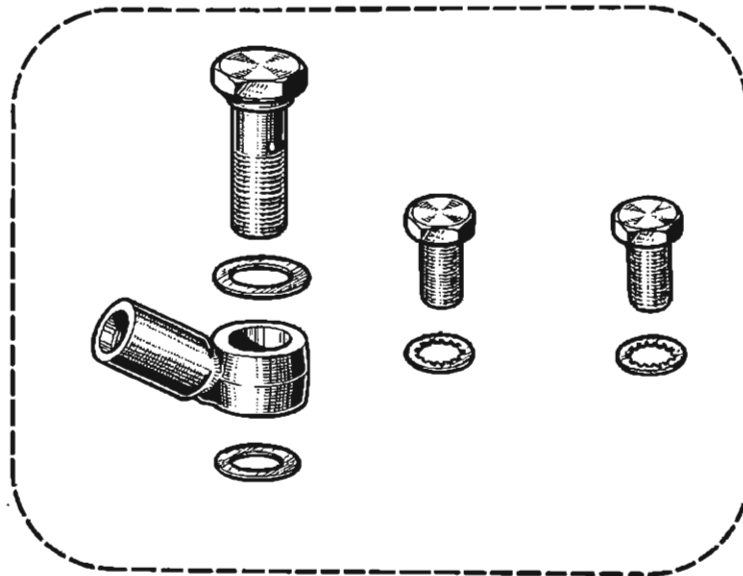
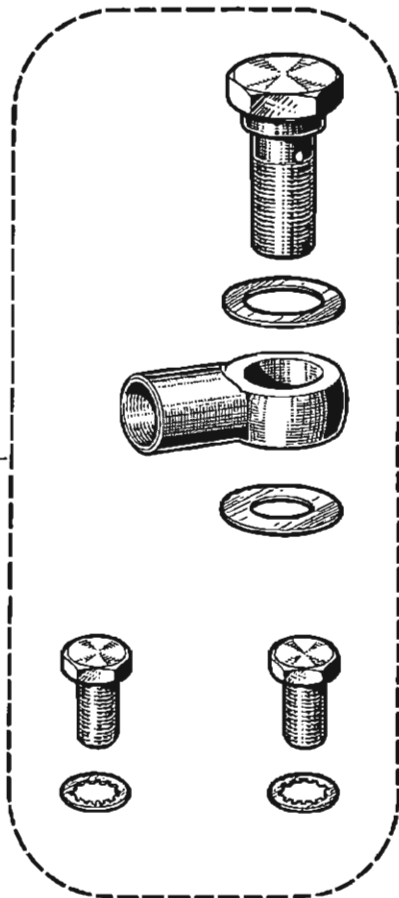

8 536 088 (R. 1062) (R. 2071)

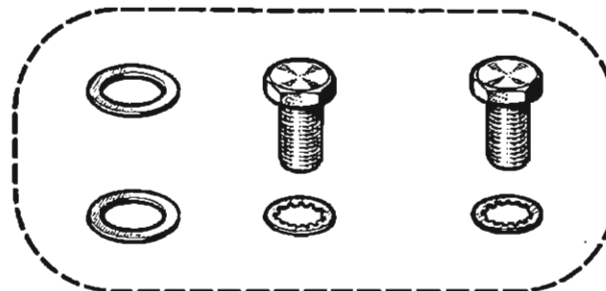

8 541 112 (R. 1082)

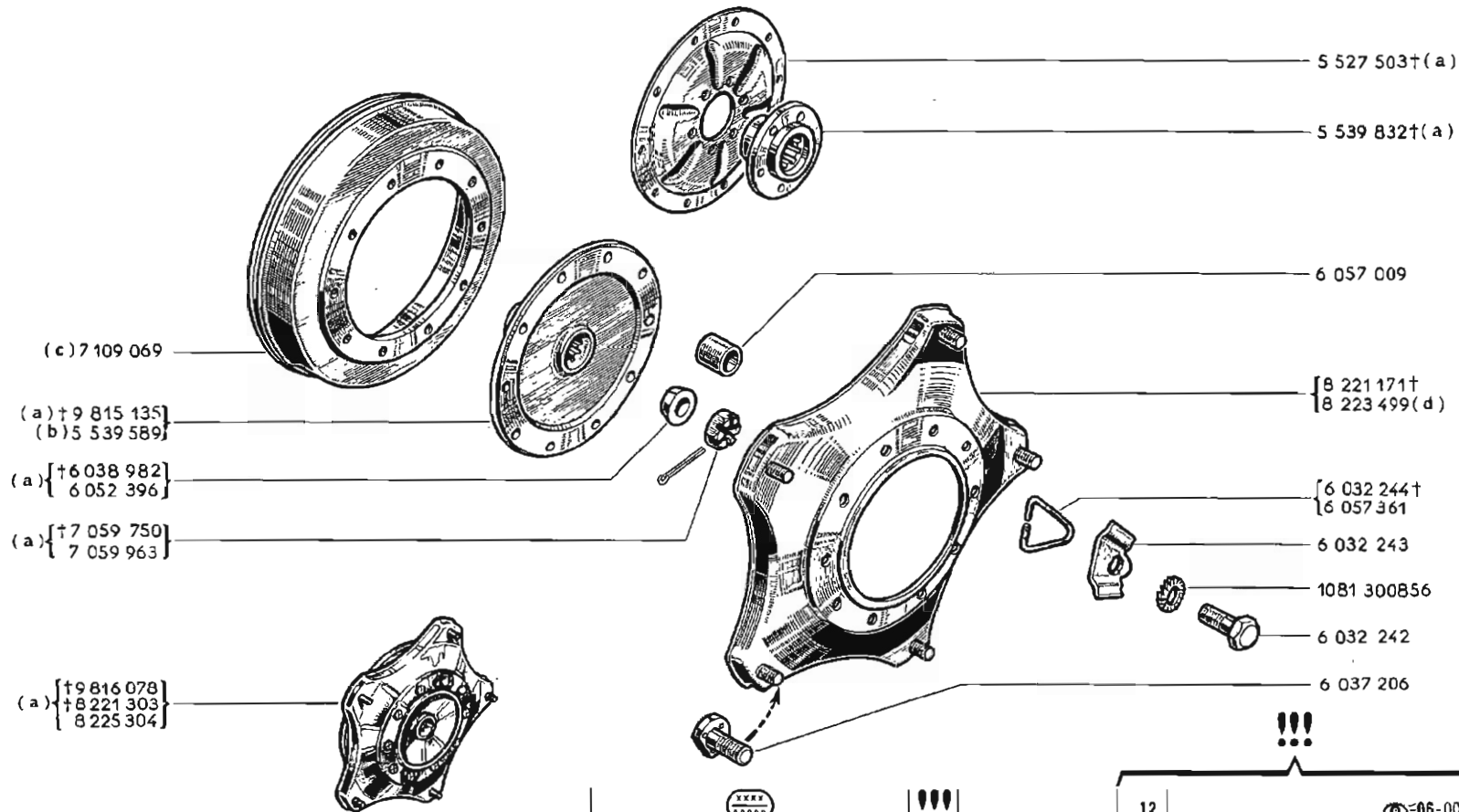

10	XXXX 00000	08-00
----	---------------	-------



	n°...	n°...	!!!
(a)		10	
(b)			201
(c)			12
(d)			198



!!!

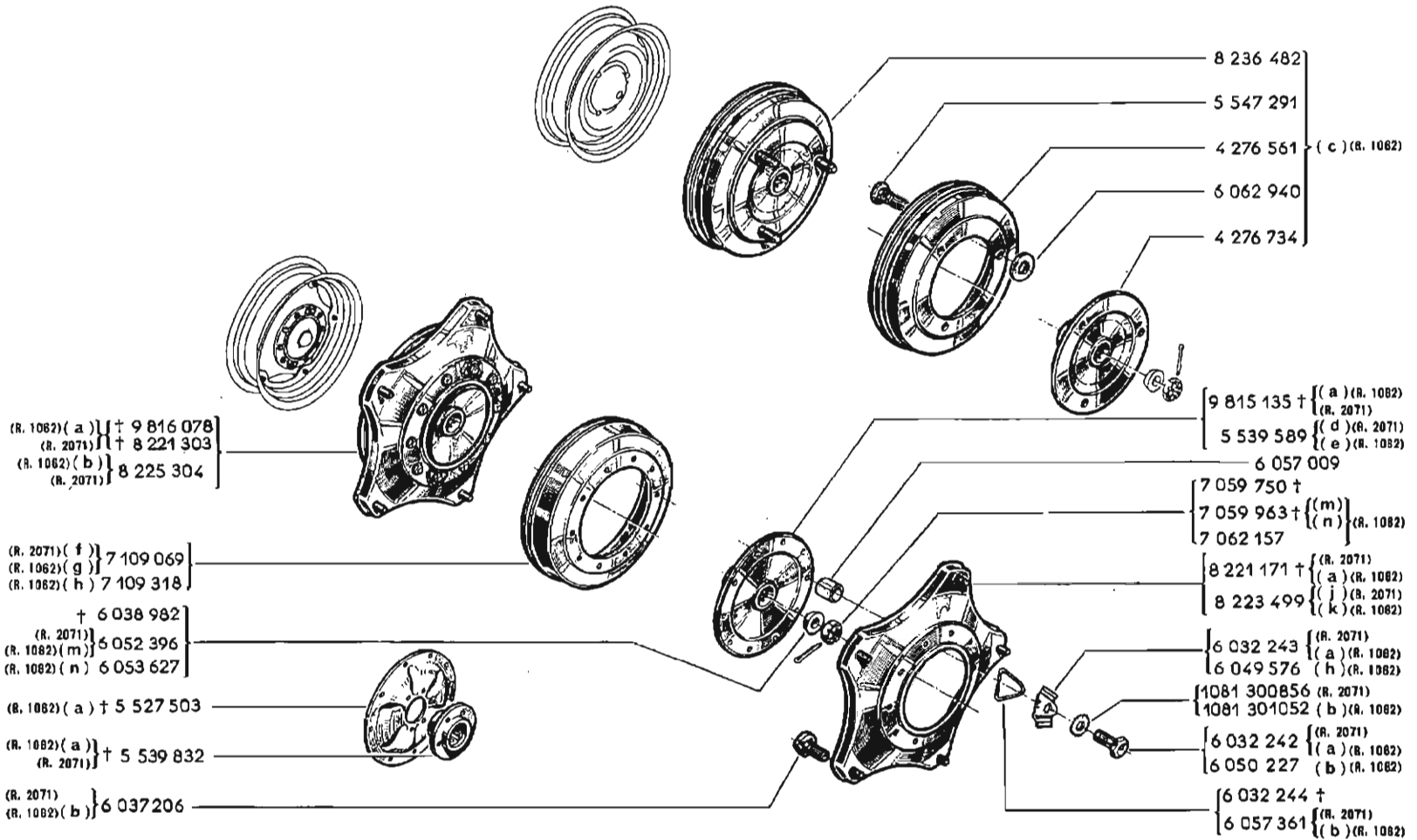



12	06-00
196	6057008 -10-
201	6057008 -10- 6054434 -1-





83	 
86	

	n°...	n°...		
(a)	1 TAR	102150		
	103197 TAR	103996		
(b)	1 VEH	748117		83
(c)	748118 VEH	...	83	
(d)				201
(e)	1 VEH	748117	83	201
(f)				12
(g)	1 TAR	102150		12
	103197 TAR	103996		12
(h)	102151 TAR	103196		
	103997 TAR	...		
	1 VEH	748117	83	
(j)				196
(k)	102151 TAR	103196		196
	103997 TAR	...		
	1 VEH	748117	83	
(m)	1 TAR	34141		86
(n)	34142 TAR	...	86	

12		
196		6057009 -10-
201		6057009 -10- 6054434 -1-

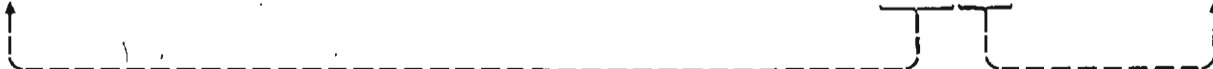

- 5 x 15 { (R. 1060) (R. 2070) (R. 2071) (R. 1082 SERVICE) (a) (R. 1082) (b) } **RENAULT 8 220 703 16**
- 5 x 15 { (R. 1060) (R. 2070) (R. 2071) (R. 1082) (b) } **MICHELIN † 8 538 648 16**
- 5 x 15 { (R. 1060) (R. 2070) (R. 2071) (R. 1082 SERVICE) (b) } **DUNLOP 8 538 649 16**
- 145 x 400 { (R. 1060) (R. 2070) (R. 2071) (R. 1082) (b) } **MICHELIN 8 513 237 16**

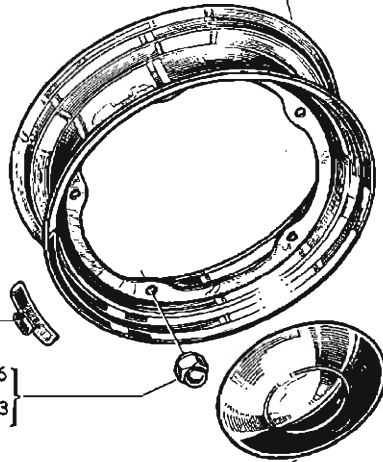

- (R. 1082 SERVICE) (b) 8 241 416
- (R. 1060) (R. 2070) (R. 2071) (R. 1082) (b) 8 240 153

- (C 11) (R. 1062 AFFAIRES) (b) 5 539 346
- (C 12) { (R. 1082) (b) 5 524 593
- { (R. 1060) (R. 2070) (R. 2071) (R. 1082) (b) 5 536 658

C 11) 100-00
C 12)

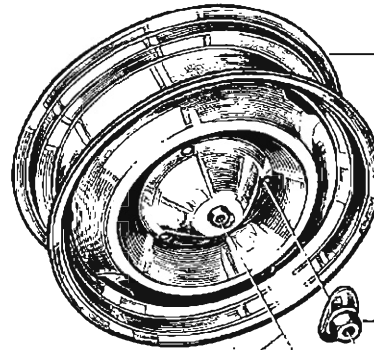

- { 8 308 004 16 † MICHELIN } (c) (R. 1082)
- { 8 308 005 16 DUNLOP }

(1)

8 236 766 (c) (R. 1082)

6 059 724 (d) (R. 1082)

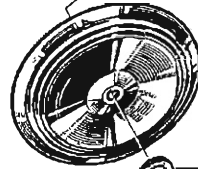

- { 5 547 178 † } (e) (R. 1082)
- { 5 553 489 } (e) (R. 1082)
- { 5 548 569 † } (f) (R. 1082)
- { 5 551 240 } (f) (R. 1082)

6 066 350 (R. 1082)

- { 6 059 725 † (c) 8 242 923 (e) 6 064 009 04 (f) 8 242 977 (e) 6 064 009 09 (f) } (R. 1082) AFFAIRES

(1)			
8541353	10 g	8541360	45 g
8541354	15 g	8541361	50 g
8541355	20 g	8541362	60 g
8541356	25 g	8541363	70 g
8541357	30 g	8541364	80 g
8541358	35 g	8541365	90 g
8541359	40 g	8541366	100 g

XXXX
00000

83

08-00

	n°...	⇒	n°...	↘	↙	!!!
(a)	229003 VEH		748117			
(b)	1 VEH		748117		83	
(c)	748118 VEH		...	83		
(d)	748118 VEH		...			
(e)	748118 VEH		812763	83		
(f)	812764 VEH		...			



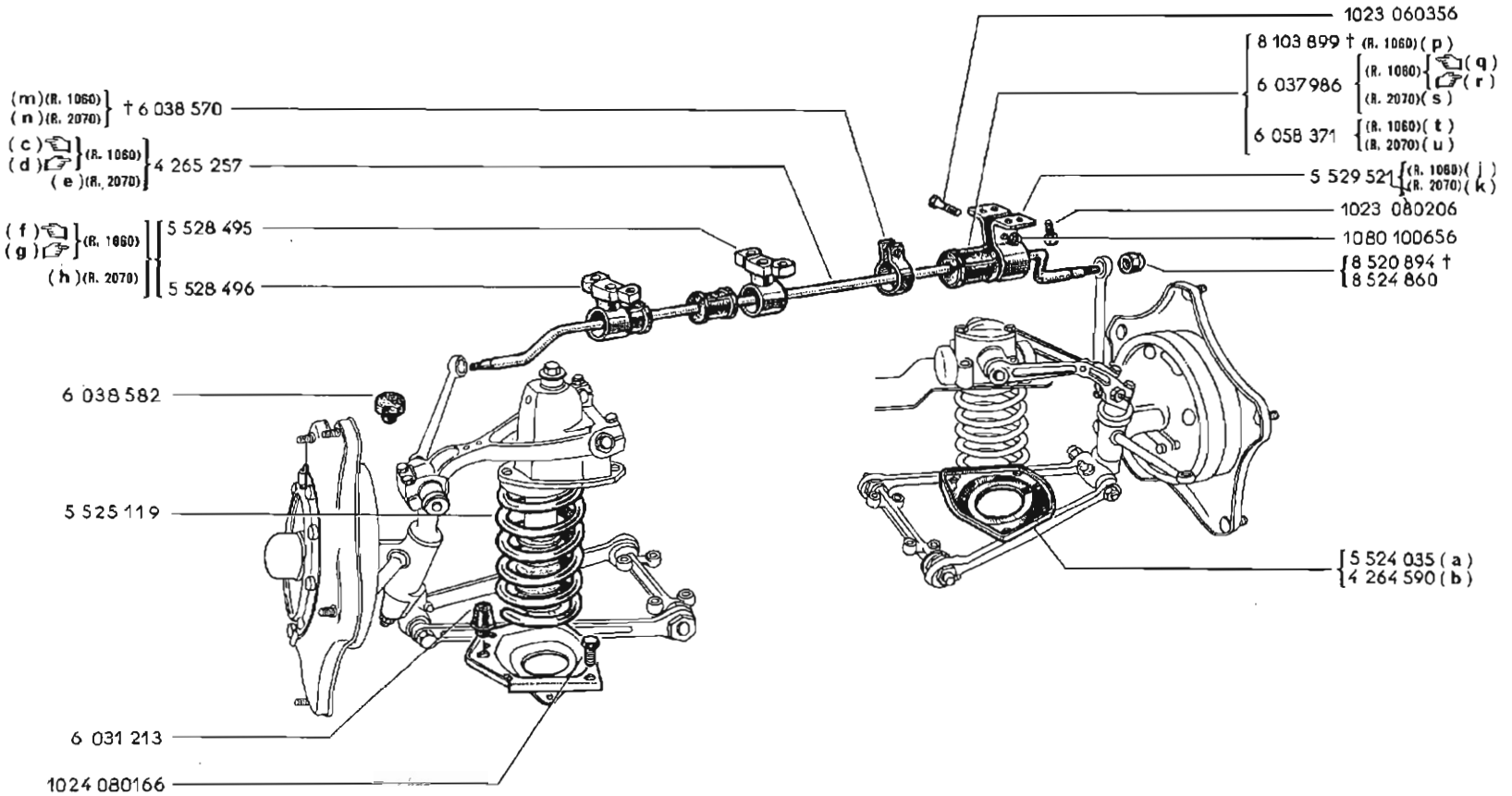

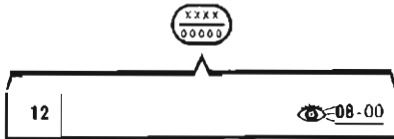

	n°...	n°...	!!!
(a)			12
(b)			12
(c)	25494 CAR	...	
(d)	2217 CAR	...	
(e)	3491 CAR	...	
(f)	25494 CAR	88141	
(g)	2217 CAR	88141	
(h)	3491 CAR	9469	
(j)	88142 VEH	...	
(k)	9470 VEH	...	
(m)	88142 VEH	110578	
(n)	9470 VEH	10104	
(p)	1 VEH	110578	
(q)	25494 CAR	110578	
(r)	2217 CAR	110578	
(s)	1 VEH	10104	
(t)	110579 VEH	...	
(u)	10105 VEH	...	

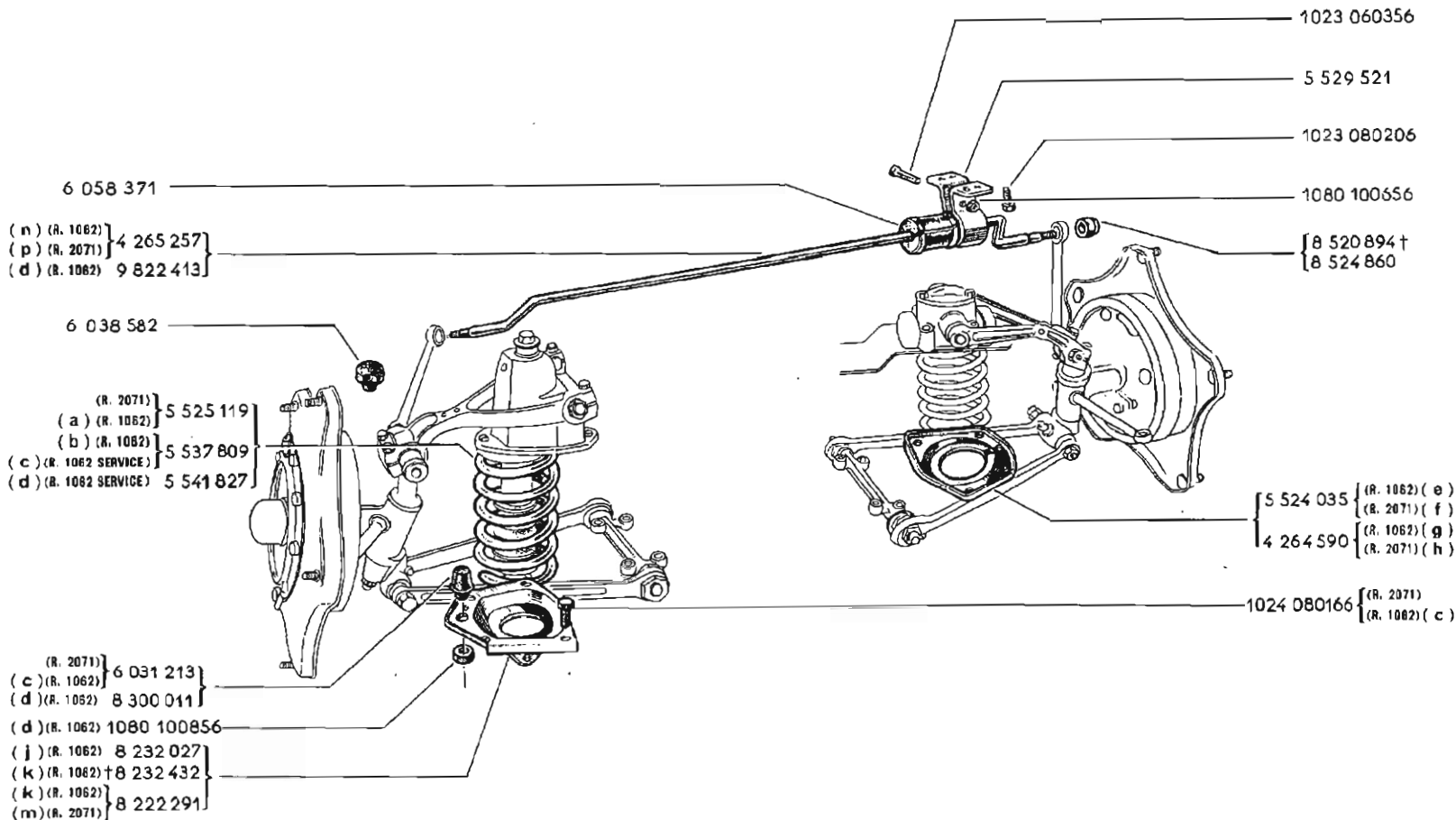

XXXX
00000

1	08-00
2	08-00
29	08-00

XXXX
00000

	n°...	n°...			!!!
(a)	1 VEH	285062			20
(b)	285063 VEH	484678			29
(c)	1 VEH	484678			29
(d)	484679 VEH	...		29	
(e)	1 VEH	49921			
(f)	1 VEH	1929			
(g)	49922 VEH	69929	2	1	
(h)	1930 VEH	2524			
(j)				1	
(k)	69930 VEH	484678		2	101
(m)	2525 VEH	...			101
(n)	1 VEH	484678		29	102
(p)					102

!!!

20	06-00
101	7061913 -1- 8524860 -1- 6044105 -1-
102	8524860 -2-



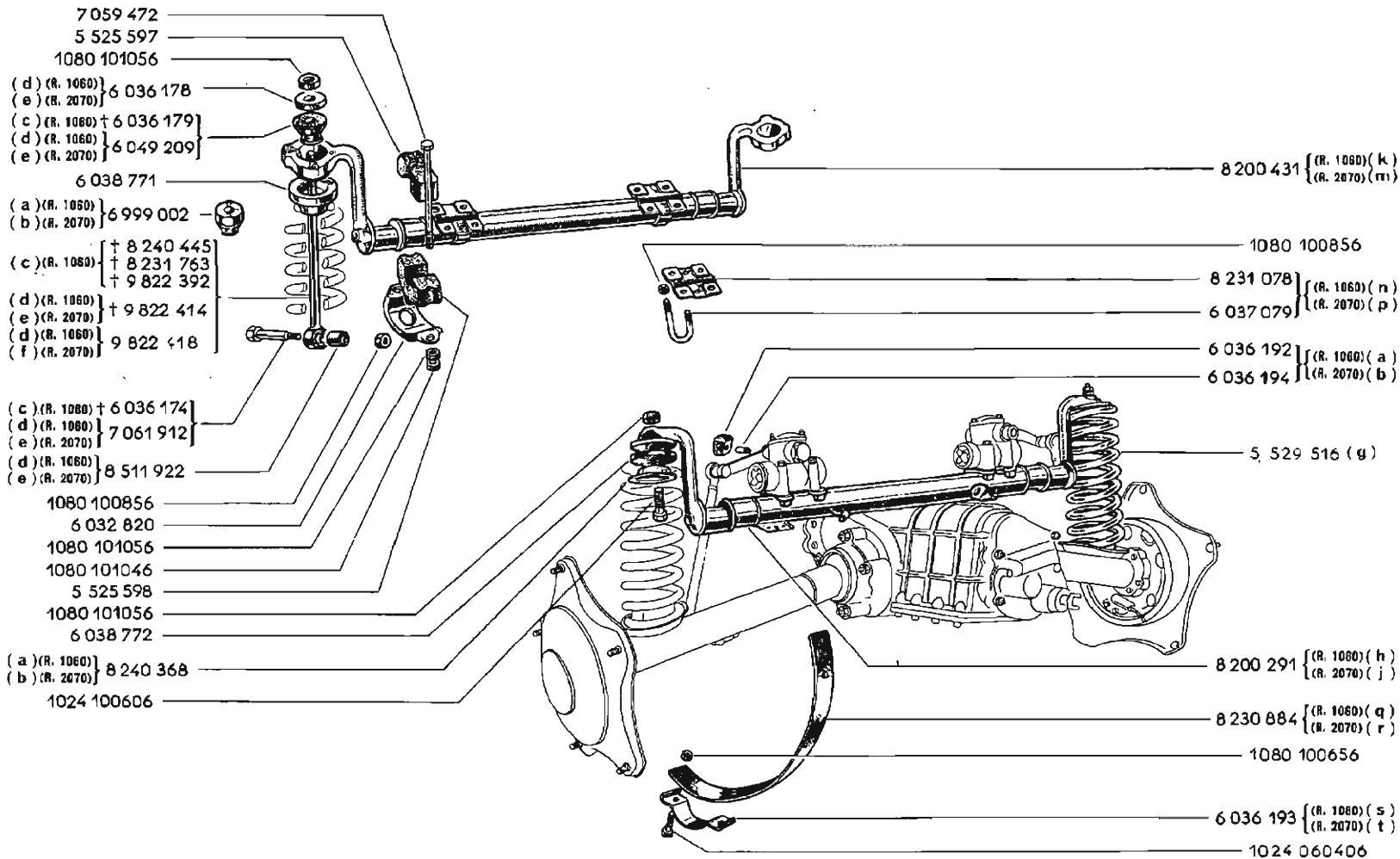

	n°...	n°...	!!!
(a)	1 VEH 33552 VEH 33570 VEH	32938 33554 33579	
(b)	1 VEH	4236	
(c)	32939 VEH	33551	
(d)	32939 VEH 33555 VEH 33580 VEH	33551 33569 ...	
(e)	4237 VEH 4317 VEH	4314 ...	
(f)	4237 VEH	...	
(g)			21
(h)	1 VEH	89689	22
(j)	1 VEH	9153	22
(k)	89690 VEH	...	
(m)	9154 VEH	...	
(n)	49188 VEH	...	
(p)	6079 VEH	...	
(q)	1 VEH 33552 VEH 33570 VEH	32938 33554 33579	103
(r)	1 VEH	4236	103
(s)	1 VEH 33552 VEH 33570 VEH	32938 33554 33579	104
(t)	1 VEH	4236	104

!!!

21		06-00
22	垂	6899002 - 2-
103	垂	6036193 - 4-
104	垂	8230884 - 4-



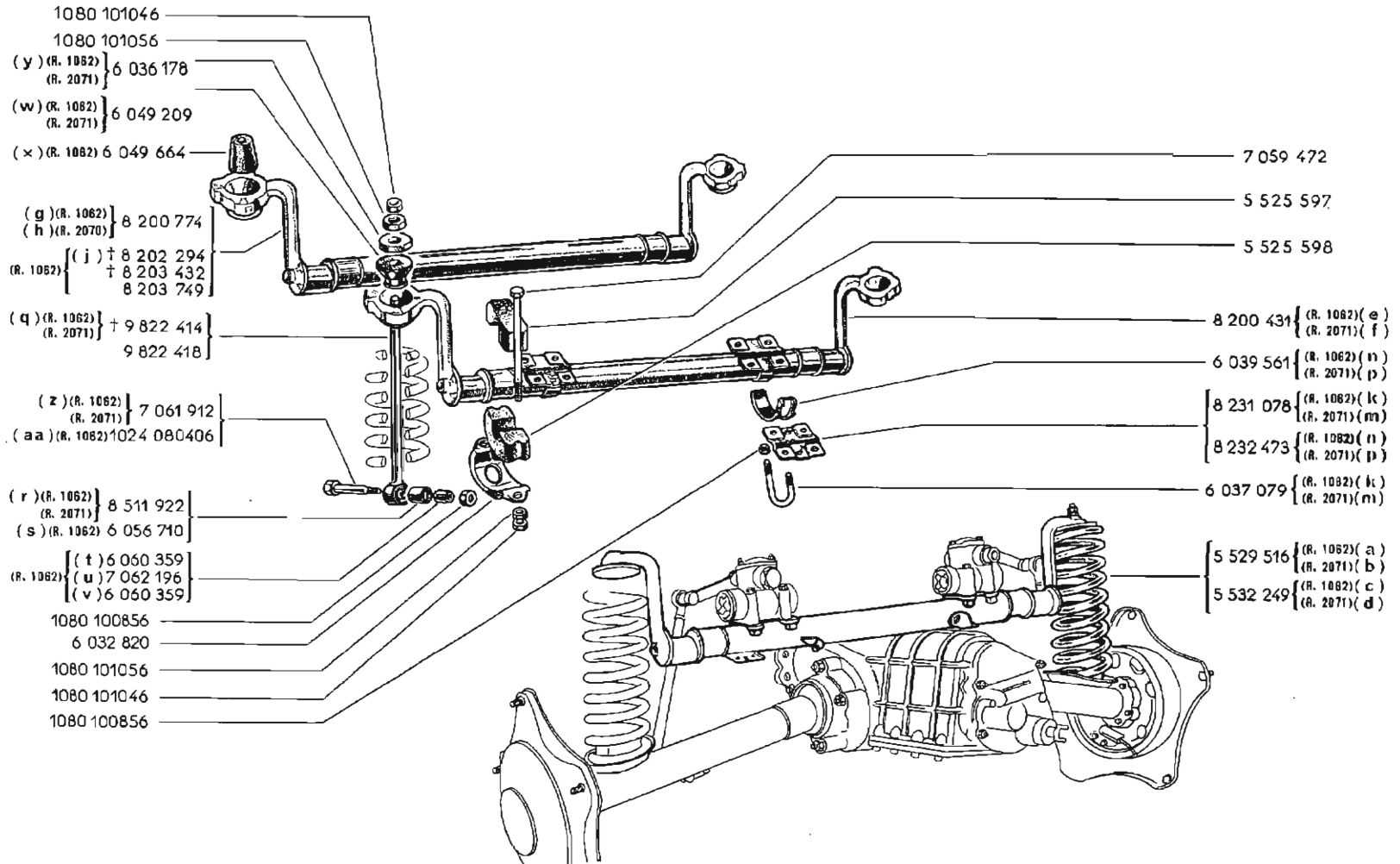

XXXX
00000

1	08-00
2	08-00
25	08-00
26	08-00
78	08-00

XXXX
00000

	n°...	n°...	!!!	!!!
(a)	1 VEH	56009		
(b)	1 VEH	2184		
(c)	56010 VEH	...		
(d)	2185 VEH	...		
(e)	1 VEH	69929	2	1
(f)	1 VEH	2524		
(g)	69930 VEH	450603	1 26	2 25
(h)	2525 VEH	...		
(j)	450604 VEH	...	26	26
(k)	1 VEH	55552		
(m)	1 VEH	2173		
(n)	55553 VEH	69929	2	1
(p)	2174 VEH	2524		
(q)	1 VEH	747273		105
(r)	1 VEH	597138	1	
(s)	597139 VEH	...		
(t)	1 VEH	597138		
(u)	597139 VEH	747273		
(v)	747274 VEH	...		
(w)	340662 VEH	...		106
(x)	340662 VEH	...		
(y)	1 VEH	340661		
(z)	1 VEH	597138	78	
(aa)	597139 VEH	...		78

!!!

105		1023 800406 -1-
106		6049664 -1- 1080 011046 -2-



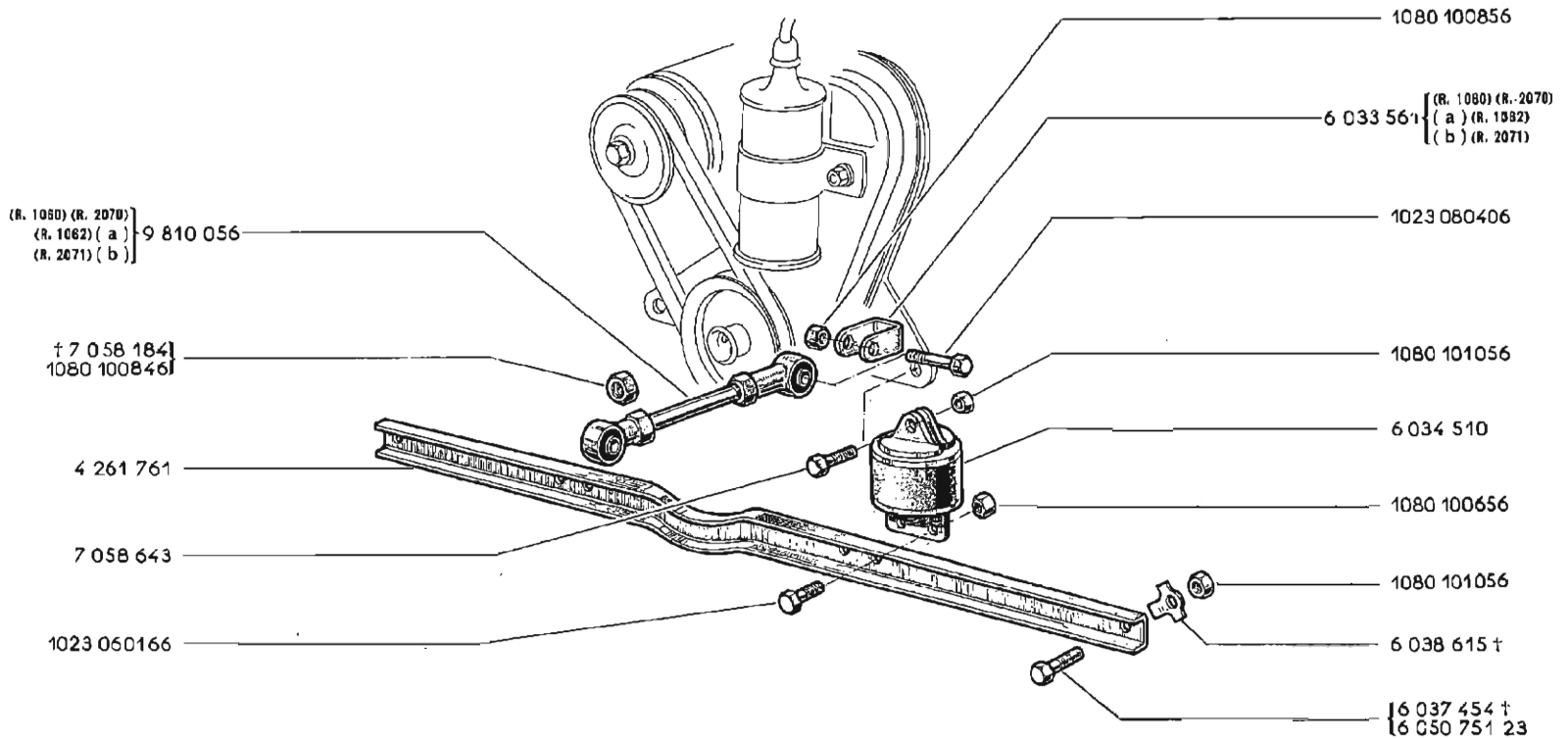





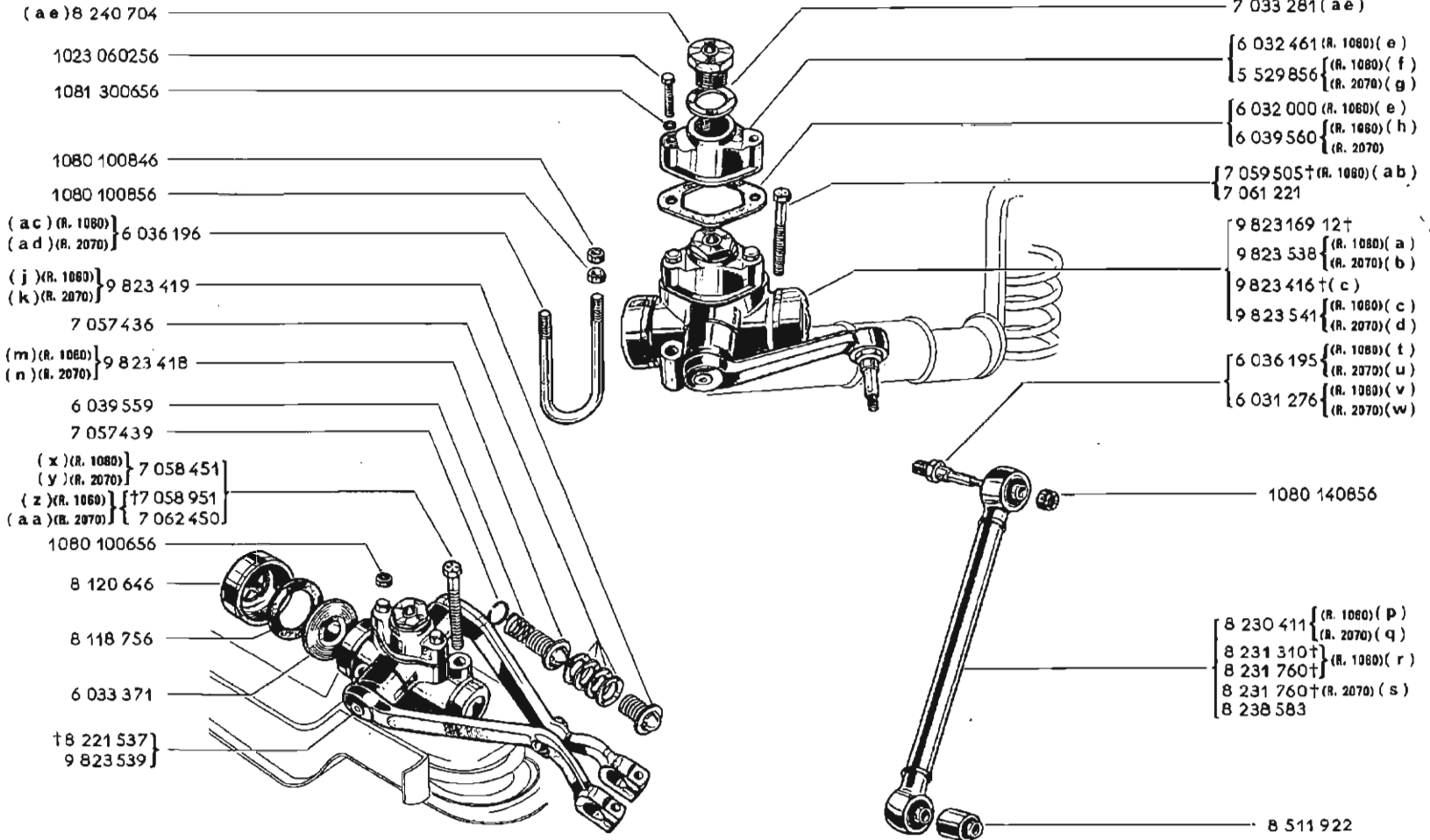

(a) VEH n° 1 ⇨ VEH n° 138346

(b) VEH n° 1 ⇨ VEH n° 4150



59		
61		

	n°...	n°...		
(a)			59	
(b)	937 VEH	4236		
(c)			59	
(d)	1 VEH 4237 VEH 4317 VEH	936 4314 ...		
(e)	1 VEH	1000		
(f)	1001 VEH	...		17
(g)				17
(h)	1001 VEH	...		
(j)	1001 VEH	...		18
(k)				18
(m)	1001 VEH	...		19
(n)				18
(p)	1 VEH	3911		
(q)	1 VEH	457		
(r)	3912 VEH	...		
(s)	458 VEH	...		
(t)	1 VEH	30271	81	
(u)	1 VEH	4236		
(v)	30272 VEH	...	81	
(w)	4237 VEH 4317 VEH	4314 ...		
(x)	1 VEH	5749		
(y)	1 VEH	779		
(z)	5750 VEH	...		
(aa)	780 VEH	...		
(ab)	1 VEH	49187		
(ac)	49188 VEH	...		
(ad)	6079 VEH	...		
(ae)	1001 VEH	...		

17		8240704 - f - 1023 060306 - 4 - 8039560 - f - 9823418 - f - 9823419 - f - 7033281 - f -
18		9823418 - f -
19		9823419 - f -



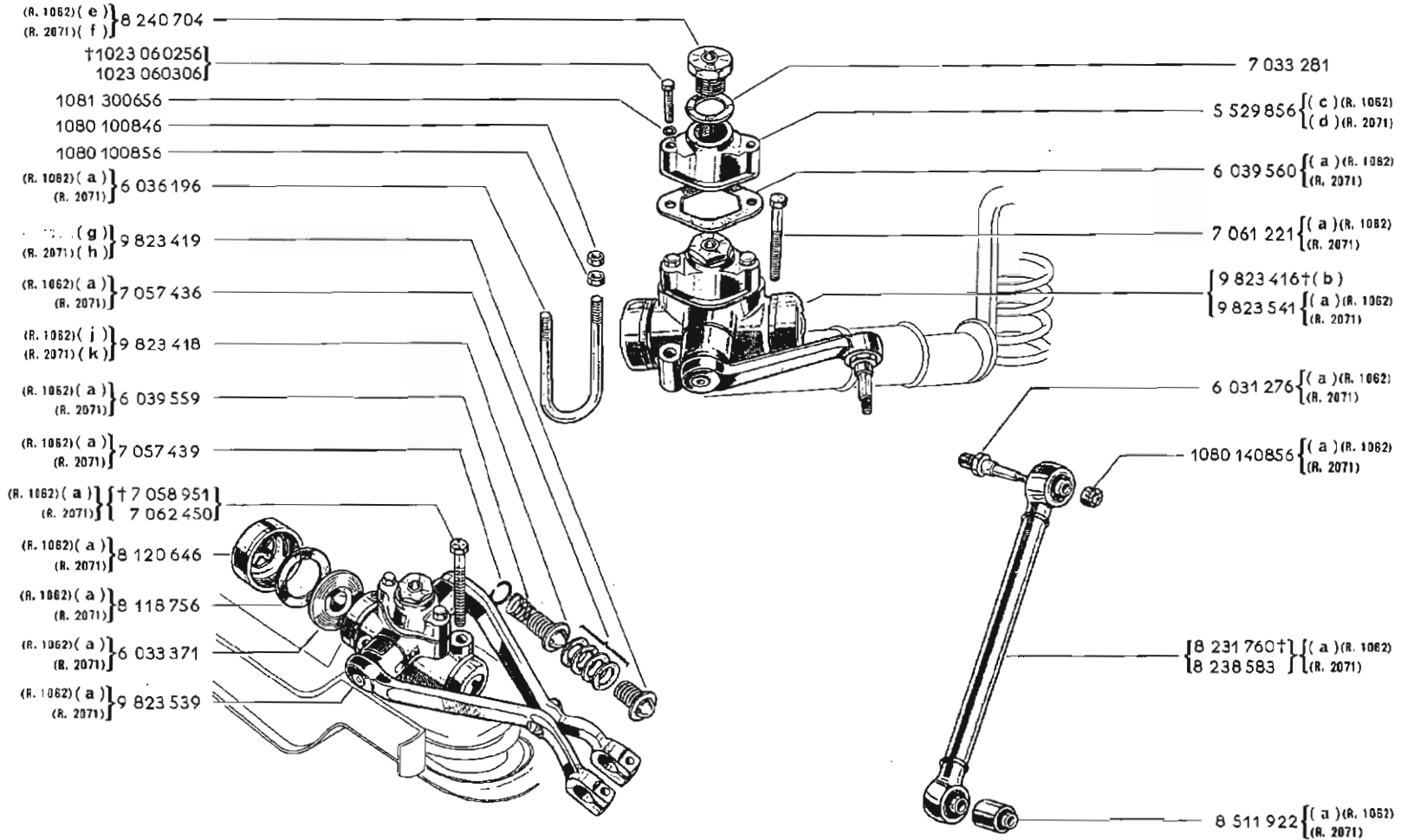

XXXX 00000	
1	👁️ 08-00
2	👁️ 08-00
59	👁️ 08-00

	XXXX 00000	!!!
n°...	⇨ n°...	⚠️
(a)		2 1
(b)		59
(c)		2 1 17
(d)		17
(e)	5420 VEH 6243 VEH	5629 ... 2 1
(f)	258 VEH 292 VEH	268 ...
(g)		2 1 18
(h)		18
(i)		2 1 19
(k)		19

!!!	
17	🚚 8240704 -1- 1023 060305 -4- 8039560 -1- 9823418 -1- 9823419 -1- 7033281 -1-
18	🚚 9823418 -1-
18	🚚 9823419 -1-



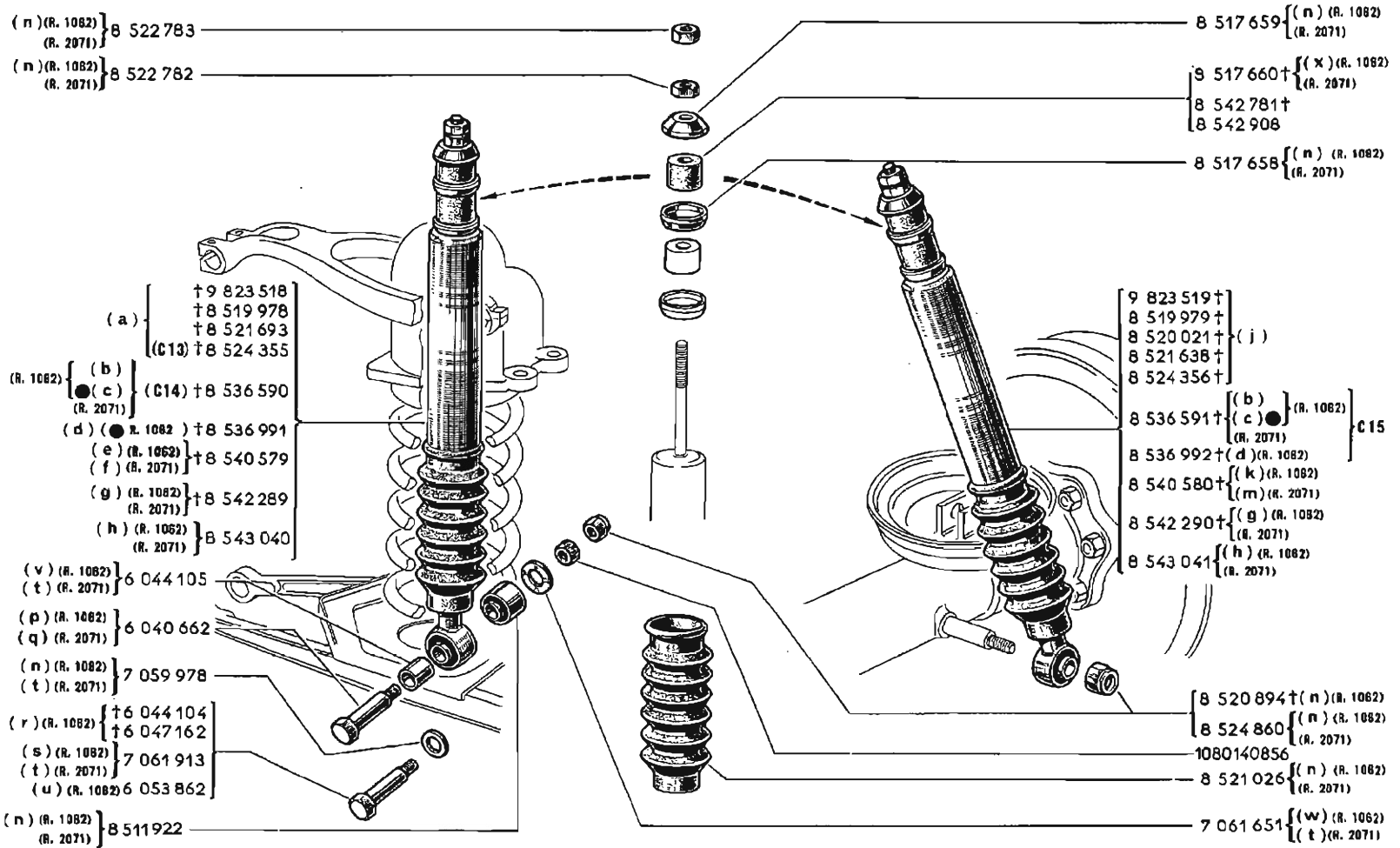

100-00

XXXX
00000

1	08-00
2	08-00
29	08-00
88	08-00

	n°...	n°...	↗	↖	!!!
(a)					44
(b)	1 VEH	746288	1	2	
(c)	1 VEH	643228			
(d)	643229 VEH	745106			
(e)	1 VEH	815323	1	2	203
(f)					203
(g)	815324 VEH	847548			
(h)	847549 VEH	...		88	
(j)					45
(k)	1 VEH	815323	1	2	204
(m)					204
(n)			1	2	
(p)	1 VEH	156564	1	2	
	156601 VEH	158033			
(q)	1 VEH	4240			
(r)	156565 VEH	156600			100
(s)	156565 VEH	156600			100
	158034 VEH	484678		29	100
(t)	4241 VEH				
(u)	484679 VEH	...		29	
(v)	156565 VEH	156600			88
	158034 VEH	484678		29	88
(w)	233992 VEH	234000			
	238050 VEH	484678		29	
(x)			1	2	253

!!!

44	+	8536580 -2-
45	+	8536591 -2-
66	+	7061651 -2-
100	+	8524860 -2-
203	+	8540579 -2-
204	+	8540580 -2-
253	+	8542781 -1- 8542908 -1- 8517858 -1- 8517659 -1-



A P.R. 685



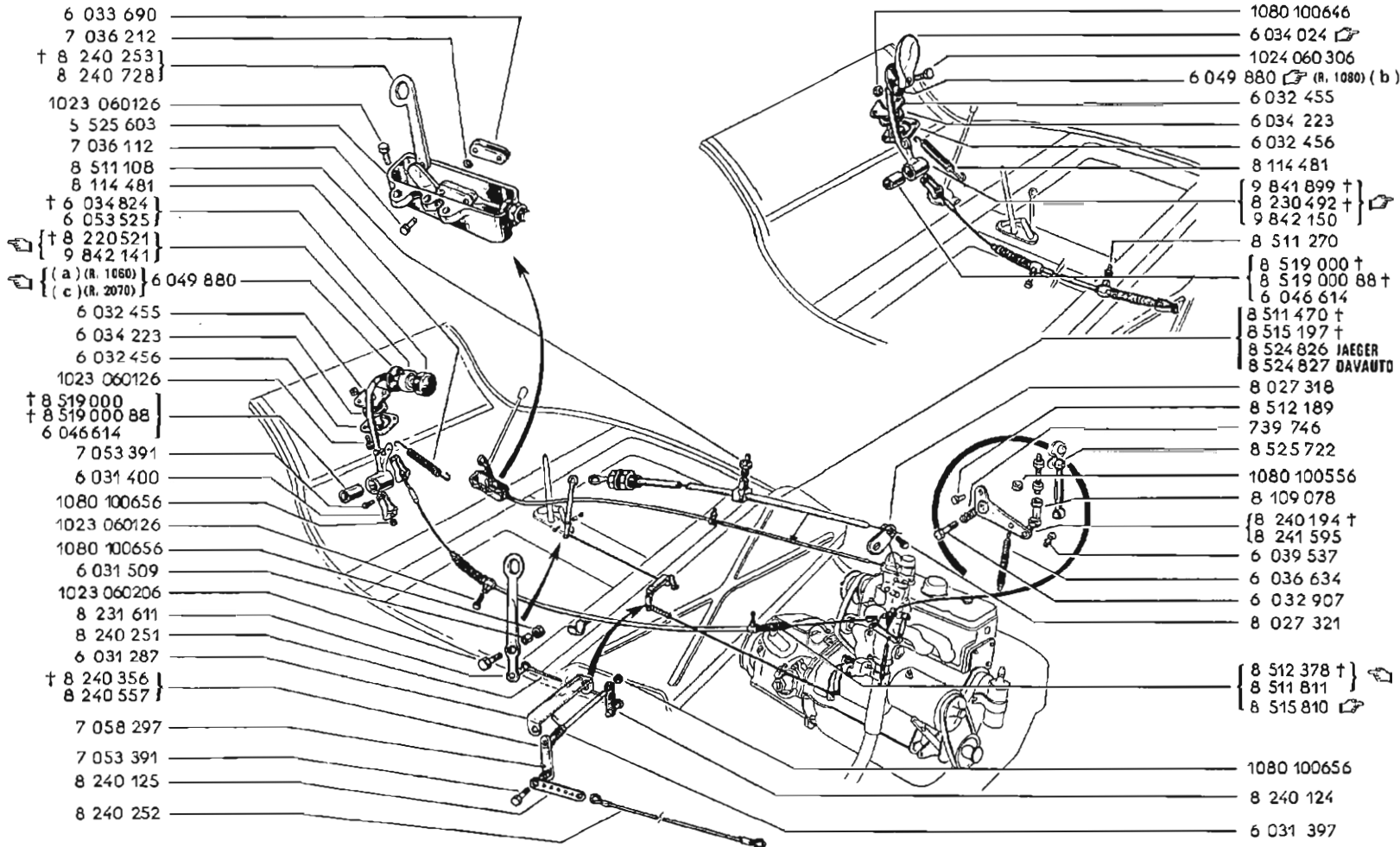

A P.R. 685

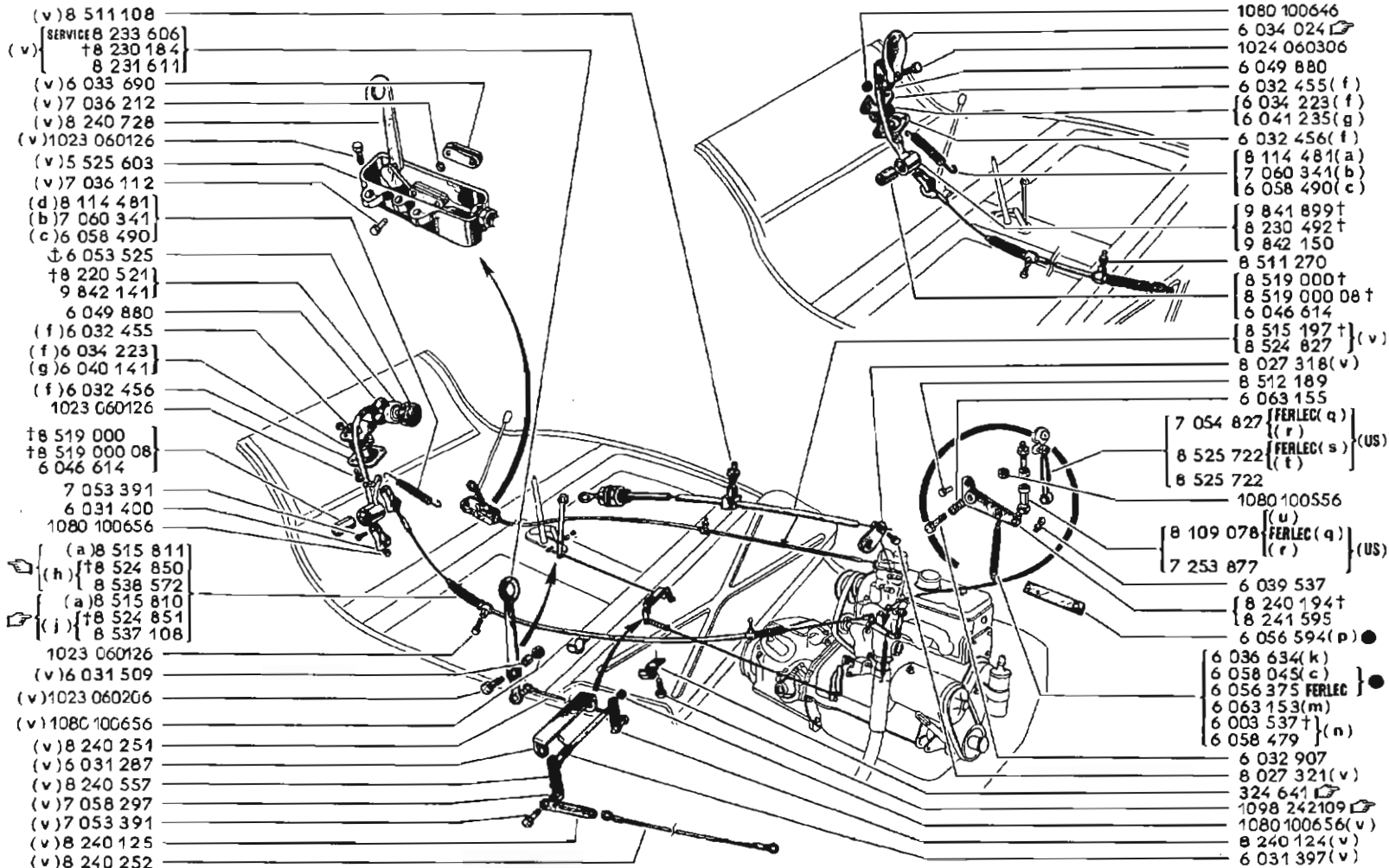

(a) CAR n° 16965 ⇨ CAR n° ...
 (b) CAR n° 1881 ⇨ CAR n° ...
 (c) CAR n° 2233 ⇨ CAR n° ...





XXXX
00000

25	 <08-00
26	 <08-00
32	 <08-00
36	 <08-00
57	 <08-00

XXXX
00000

!!!

	n°...	n°...			
(a)	1 VEH	450603	28	25	
(b)	450604 VEH	644356	25	28	
(c)	644357 VEH	...			
(d)	1 VEH	129569			
(e)	129570 VEH	450603	26	25	
(f)	1 VEH	37000			
(g)	37001 VEH	...			
(h)	450604 VEH	...	25	26	
(j)	450604 VEH	...	25	26	107
(k)	1 VEH	644356			
(m)	839642 VEH	...			
(n)	644357 VEH	839641			
(p)	496662 VEH	...	57	36	
(q)	1 MOT	75			
(r)	1 MOT	235			
(s)	76 MOT	...			
(t)	236 MOT	...			
(u)	1 VEH	236719			
(v)	1 VEH	532892		32	

!!!

107		324641 -1- 1098 242109 -1-
-----	---	-------------------------------



58.03

A P.R. 685

6 033 690
 7 036 212
 † 8 240 253]
 8 240 728]
 1023 060126
 5 525 603
 7 036 112
 8 511 108
 † 8 220 521]
 9 842 141]
 6 049 880
 (c) 6 032 455
 (c) 6 034 223]
 (d) 6 040 141]
 (c) 6 032 456
 1023 060126
 † 8 519 000
 † 8 519 000 08]
 6 046 614
 7 053 391
 6 031 400
 1080 100656
 (a) 8 114 481]
 (b) 7 060 341]
 8 231 611
 1023 060126
 1080 100656
 6 031 509
 1023 060206
 8 240 251
 6 031 287
 † 8 240 356]
 8 240 557]
 7 058 297
 7 053 391
 8 240 125
 8 240 252

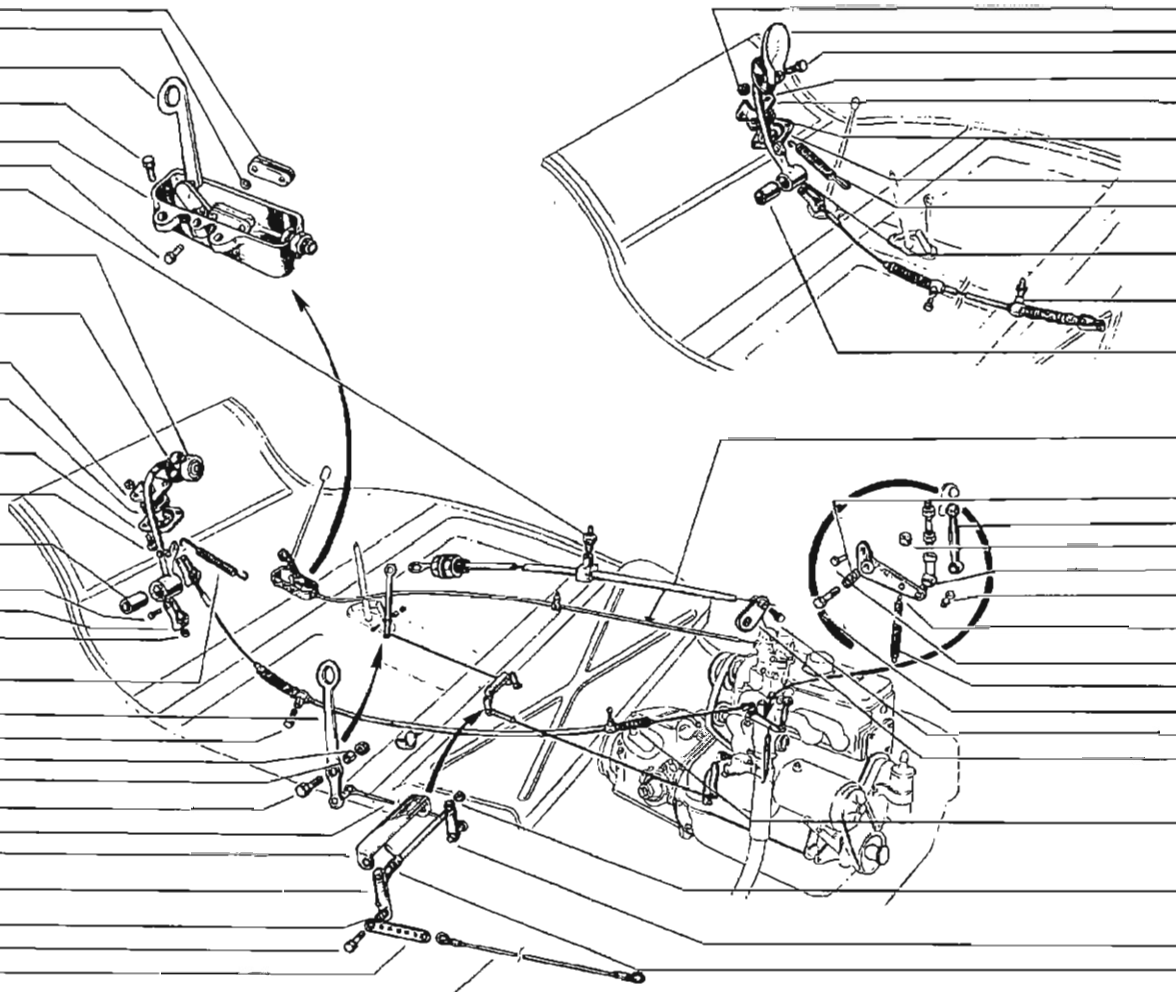

R. 2071

58.03

A P.R. 685

1080 100646
 6 034 024]
 1024 060306
 6 049 880
 6 032 455 (c)
 [6 034 223 (c)
 [6 041 235 (d)
 6 032 456 (c)
 8 114 481]
 9 841 899 †
 8 230 492 †
 9 842 150
 8 511 270
 8 519 000 †
 8 519 000 08 †
 6 046 614
 8 511 470 †
 8 515 197 †
 8 524 826 JAEGER
 8 524 827 DAVAUTO
 6 063 155
 8 525 722
 1080 100556
 8 109 078 (e)
 6 039 537
 [8 240 194 †
 [8 241 595
 8 512 189
 6 036 634
 6 032 907
 8 027 321
 8 027 318
 [8 512 378 †]
 [8 515 811]
 [8 515 810]
 1080 100656
 8 240 124
 6 031 397

(a) VEH n° 1 □ VEH n° 3952
 (b) VEH n° 3953 □ VEH n° ...
 (c) VEH n° 1 □ VEH n° 1600
 (d) VEH n° 1601 □ VEH n° ...
 (e) VEH n° 1 □ VEH n° 4240

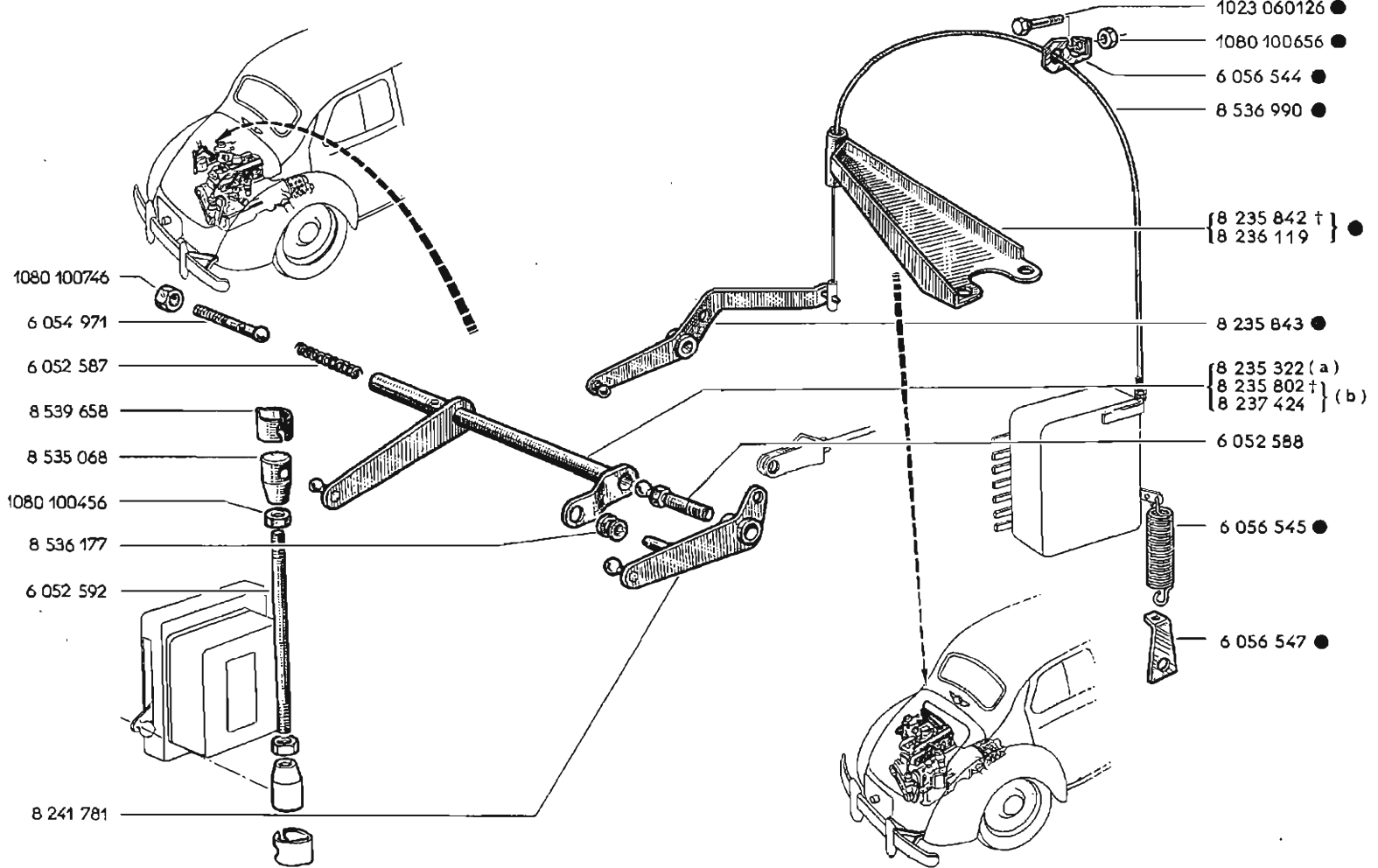

(a) MOT n° 1 ⇨ MOT n° 521144
(b) MOT n° 521145 ⇨ MOT n° ...

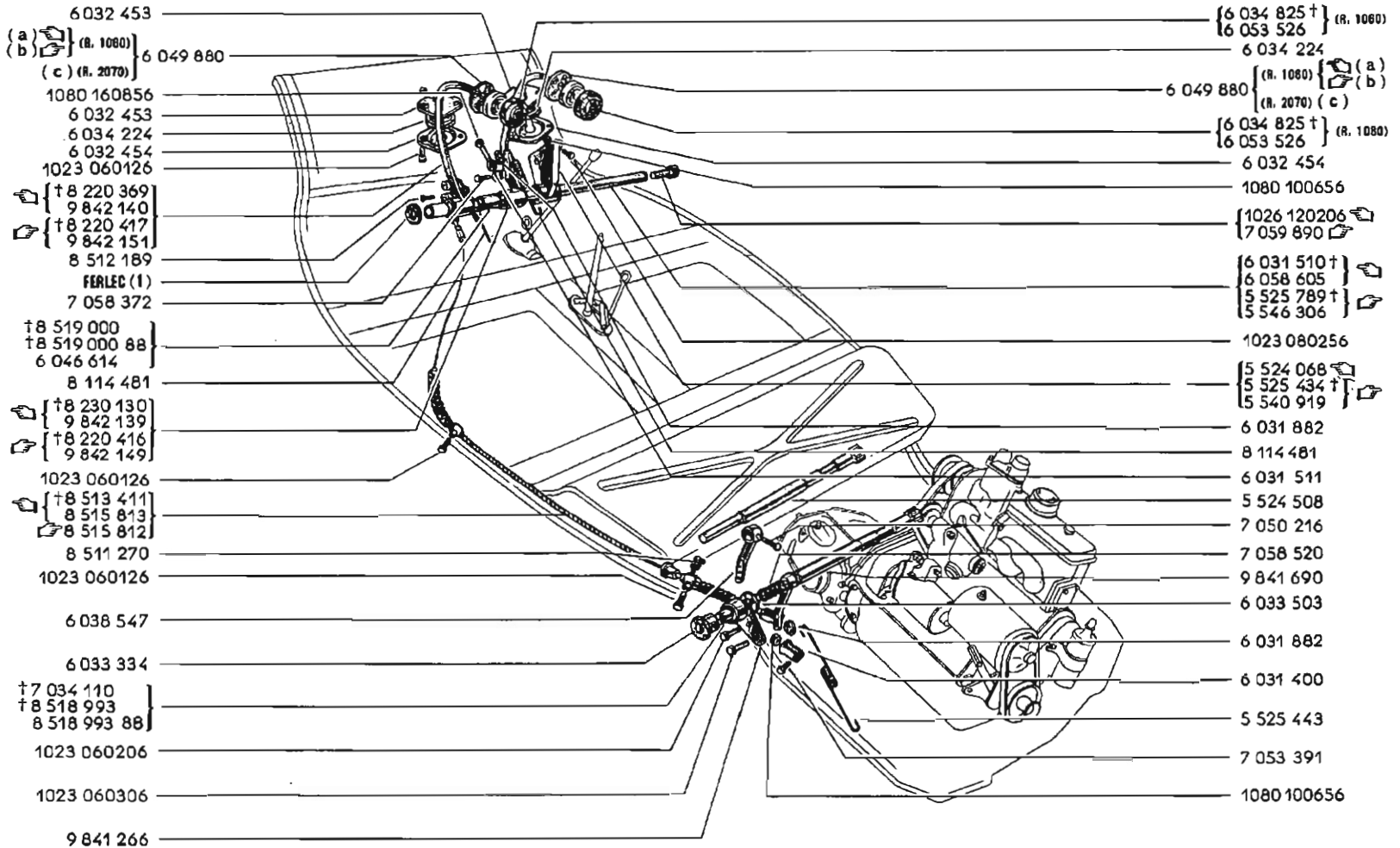

- 6032 453
- (a) (b) (c) (R. 1060) (R. 2070)
- 1080 160856
- 6032 453
- 6034 224
- 6032 454
- 1023 060126
- †8 220 369
- 9 842 140
- †8 220 417
- 9 842 154
- 8 512 189
- FERLEC (1)
- 7 058 372
- †8 519 000
- †8 519 000 88
- 6 046 614
- 8 114 481
- †8 230 130
- 9 842 139
- †8 220 416
- 9 842 149
- 1023 060126
- †8 513 411
- 8 515 813
- 8 515 812
- 8 511 270
- 1023 060126
- 6038 547
- 6033 334
- †7 034 110
- †8 518 993
- 8 518 993 88
- 1023 060206
- 1023 060306
- 9 841 266

- {6 034 825 †} (R. 1060)
- 6 053 526
- 6 034 224
- 6 049 880 (R. 1060) (a) (b) (c)
- {6 034 825 †} (R. 1060)
- 6 053 526
- 6 032 454
- 1080 100656
- {1026 120206
- 7 059 890
- {6 031 510 †}
- 6 058 605
- 5 525 789 †
- 5 546 306
- 1023 080256
- {5 524 068
- 5 525 434 †
- 5 540 919
- 6 031 882
- 8 114 481
- 6 031 511
- 5 524 508
- 7 050 216
- 7 058 520
- 9 841 690
- 6 033 503
- 6 031 882
- 6 031 400
- 5 525 443
- 7 053 391
- 1080 100656

(1)
6031389 E=2
7052158 E=1,5

(a) CAR n° 16695 ⇨ CAR n° ...
(b) CAR n° 1881 ⇨ CAR n° ...
(c) CAR n° 2233 ⇨ CAR n° ...

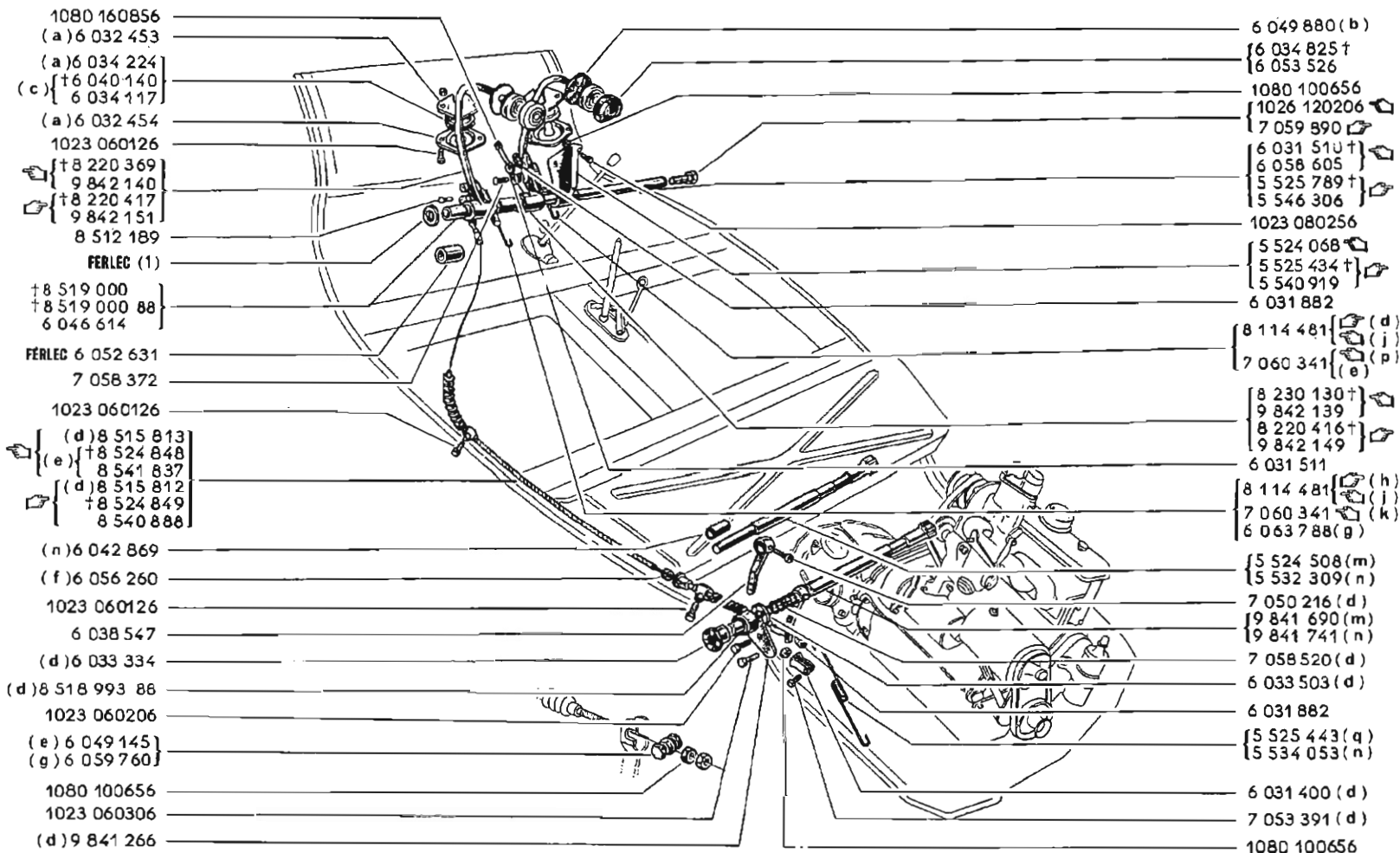

(1)
 6031389 £ = 2
 7058158 £ = 1,5

XXXX
00000

1	08-00
2	08-00
25	08-00
28	08-00

XXXX
00000

	n°...	⇨	n°...	↘	↙	!!!
(a)	1 VEH		37000			
(b)	1 VEH		812766			
(c)	37001 VEH		...			
(d)	1 VEH		450603	26	25	
(e)	450604 VEH		...	25	25	
(f)	450604 VEH		522642			
(g)	916909 MOT		...			
(h)	1 VEH		208161			
(j)	1 VEH		129569			
(k)	129570 VEH		208161			
(m)	1 VEH		69929	1	2	
(n)	69930 VEH		450603	1	2	
				26	25	
(p)	129570 VEH		450603	26	25	
(q)	1 VEH		69929	2		



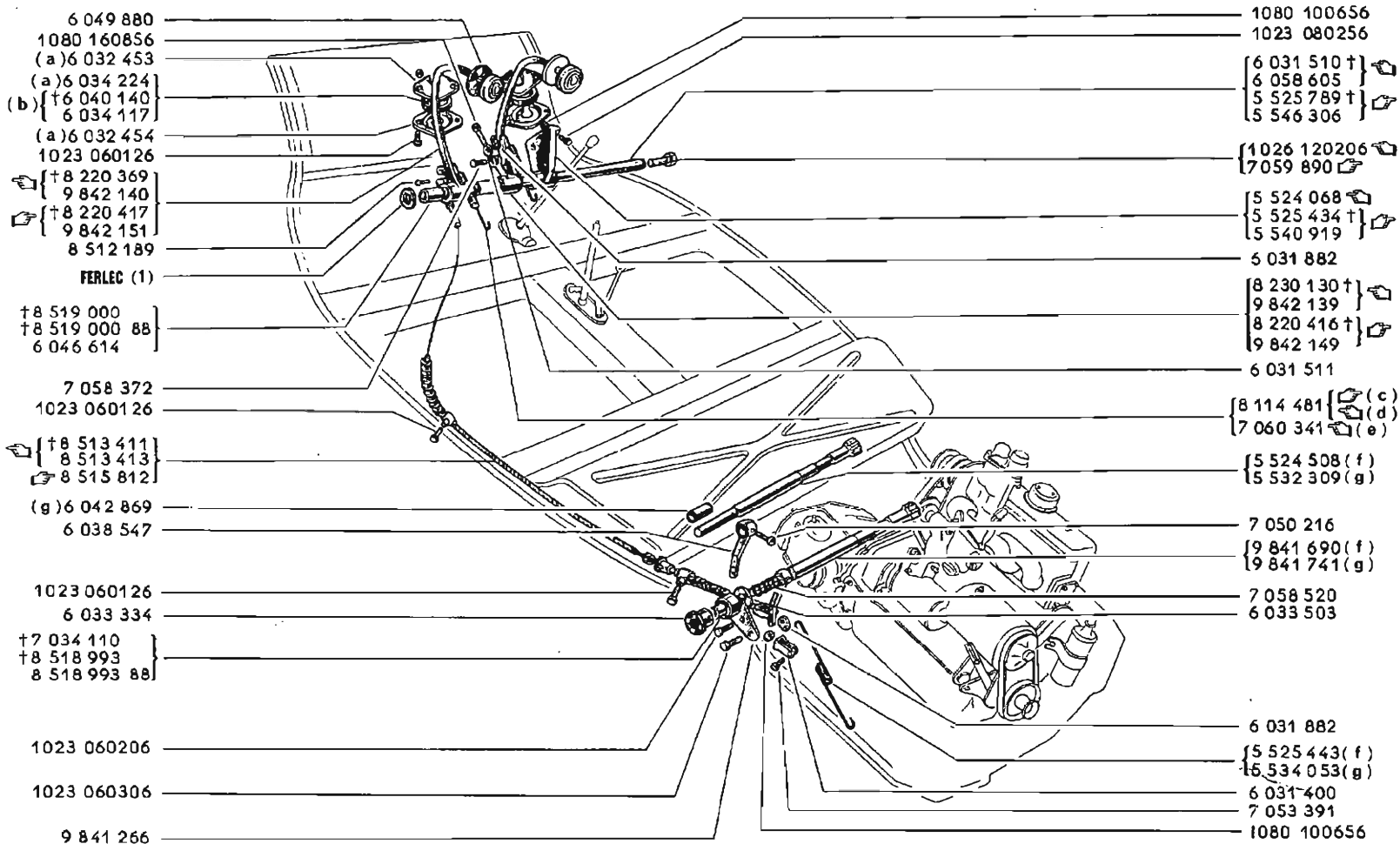

(1)
6031389 £=2
7058158 £=1.5

- (a) VEH n° 1 ⇨ VEH n° 1600
- (b) VEH n° 1601 ⇨ VEH n° ...
- (c) VEH n° 1 ⇨ VEH n° 4240
- (d) VEH n° 1 ⇨ VEH n° 3952
- (e) VEH n° 3953 ⇨ VEH n° 4240
- (f) VEH n° 1 ⇨ VEH n° 2524
- (g) VEH n° 2525 ⇨ VEH n° ...

C 16 { (a) { 6 031 404
 †6 036 110
 (b) { (GRAND LUXE)(US) † 6 050 034
 † 8 516 490
 C 17 GRAND LUXE)(US) 6 050 035

†9 841 262
 †9 808 425
 †9 841 581
 †9 841 923
 9 841 924

(c) { †6 035 130
 †6 056 396
 6 061 562

6 033 695

†7 058 022
 6 056 167

†6 031 375
 6 058 281

†7 034 175
 †7 058 019
 8 518 992

7 058 471

9 841 260

†6 033 696
 6 053 455

6 056 408

†6 034 323
 6 042 818

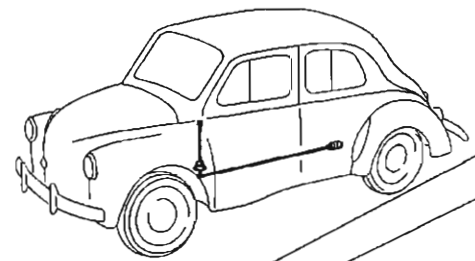

7 054 506

{ 7 058 469†
 6 058 047†
 6 059 563

7 054 470

{ 8 240 171†
 8 243 052

1089 020200

1081 110656

6 056 408

6 037 985

6 031 414

{ 6 031 398†
 6 055 955

(a)	{ R 1060 VEH n°	1	⇨	VEH n° 108900
	{ R 2070 VEH n°	1	⇨	VEH n° 10100
(b)	{ R 1060 VEH n°	108901	⇨	VEH n° ...
	{ R 2070 VEH n°	10101	⇨	VEH n° ...
(c)	{ R 1060 VEH n°	2201	⇨	VEH n° ...
	{ R 2070 VEH n°	231	⇨	VEH n° ...

C 18) Ⓢ 100-00
 C 17)

	n°...	n°...	!!!
(a)	1 VEH	585208	
(b) R.2071 R.1062	1 VEH	585208	
(c)	585209 VEH	713663	
(d) R.1062	713664 VEH	...	87
(e)	713664 VEH	742155	87
(f)	742156 VEH	...	
(g) R.2071 R.1062 R.1062 FERLEC	1 VEH	742155	87
(h) R.1062 FERLEC	742156 VEH	...	87
(i)			87
(k) R.1062 R.2071	1 VEH 1 VEH	163448 4240	
(m)			108
(n) R.2071 R.1062	1 VEH	715183	
(p) R.1062	715184 VEH	774063	
(q) R.1062	774064 VEH	...	87
(r)	1 VEH	742155	
(s)	742156 VEH	774063	
(t) R.1062	774064 VEH	...	
(u)	1 BP	3500	
(v)	3501 BP	...	
(w) R.2071 R.1062 R.1062	1 VEH 405601 VEH	405209 406426	
(x)	1 VEH 405601 VEH	405209 406426	
(y)	405210 VEH 406427 VEH	405600 ...	
(z)			87 109
(aa) R.2071 R.1062	1 VEH	500316	
(ab) R.1062	500317 VEH	...	87
(ac) R.2071 R.1062 FERLEC R.1062	1 VEH 1 VEH	713663 715183	
(ad) R.1062 FERLEC R.1062	713664 VEH 715184 VEH	87
(ae) R.2071 R.1062	1 VEH	500324	
(af) R.2071 R.1062	1 VEH	774063	175
(ag) R.2071 R.1062	774064 VEH	...	87
(ah) R.1062			175

87

XXXX
00000

08-00

!!!

108	☞	6050034 -1-
109	☞	8119779 -1-
175	☞	1081 110656 -1-

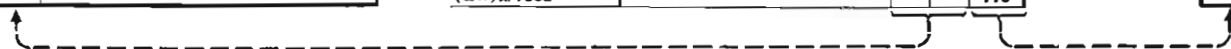

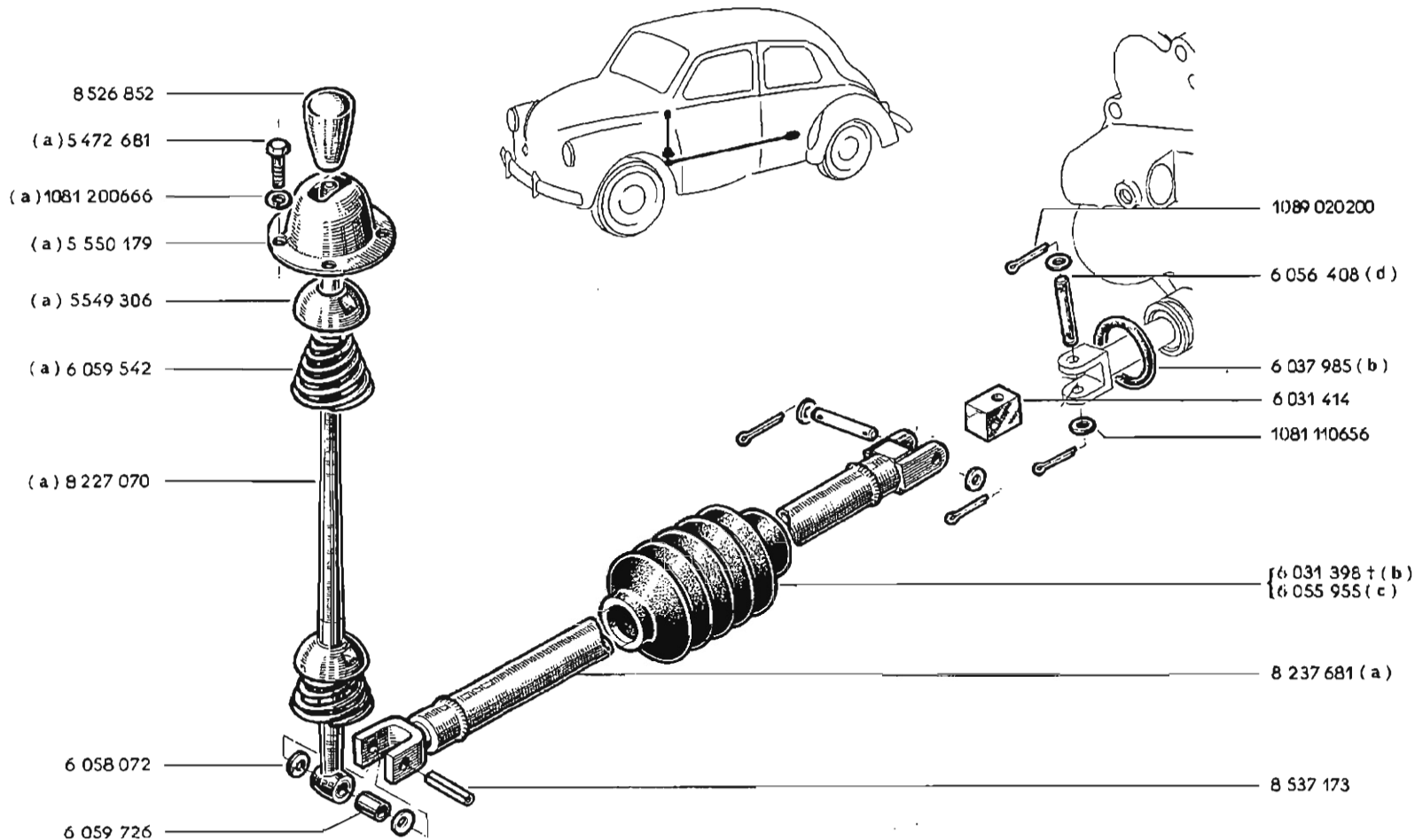

XXXX
00000

87

08-00

	n°...	⇨	n°...	↙	↘	!!!
(a)					87	
(b)	841461 VEH		896938			
(c)	896939 VEH		...			
(d)						175

!!!

175

1081 110658 -1-



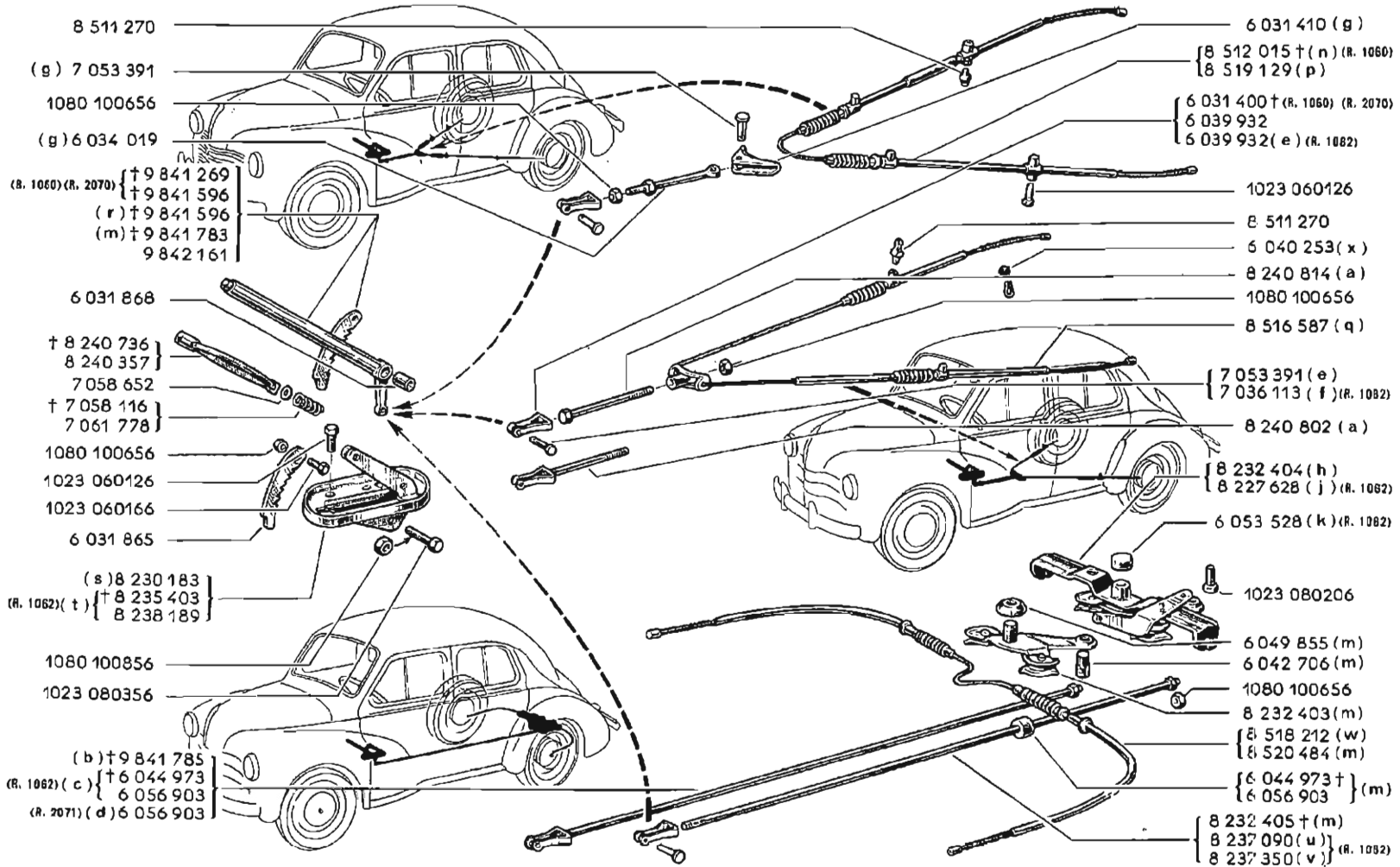

XXXX 00000	
15	08-00
16	08-00
32	08-00
47	08-00
82	08-00
63	08-00

XXXX 00000		!!!	
n°...	n°...		
(a)	138840 VEH R 1060 ... 1 VEH R 1062 194782 10687 VEH R 2070 ... 1 VEH R 2071 4240	47	
(b)	194783 VEH R 1062 846992 4241 VEH R 2071 ...	47	256
(c)	194783 VEH ...	47	
(d)	4241 VEH ...		
(e)	1 VEH R 1082 846992		
(f)	846993 VEH ...		
(g)	1 VEH R 1060 90604 1 VEH R 1062 9542	15	
(h)	194783 VEHR 1062MOT916908 4241 VEH R 2071 ...	47	110
(j)	916909 VEH ...		
(k)	489909 VEH ...		
(m)	194783 VEH R 1062 ... 4241 VEH R 2071 ...	47	
(n)	1 VEH 300		
(p)	301 VEH R 1060 90604 1 VEH R 2070 9542	15	206
(q)	90605 VEH R 1060 ... 1 VEH R 1062 32644 34445 VEH R 1062 34507 9552 VEH R 2070 ... 1 VEH R 2071 1470	15 16	23
(r)	1 VEH R 1062 194782 1 VEH R 2071 4240	47	
(s)	R 1060 R 2070 R 2071 1 VEH R 1062 532892	32	
(t)	532893 VEH ...	32	
(u)	194783 VEH 864992	47	
(v)	846993 VEH ...		231
(w)	R 1060 32645 VEH R 1062 34444 34508 VEH R 1062 194782 R 2070 1477 VEH R 2071 4240	18 47 62	
(x)	90605 VEH R 1060 ... 1 VEH R 1062 192504 9552 VEH R 2070 ... 1 VEH R 2071 4240	63	15

!!!	
23	8240802 -1- 1080 100656 -2-
110	6053528 -1-
206	6039932 -1- 7053391 -1- 6034019 -1- 1080 100656 -1- 6031410 -1- 7053391 -1-
231	06-00
256	8237350 -1-



58.71

A P.R. 685

(v) 8 510 569
 (R. 1062) (w) 8 546 159
 7 055 628
 8 539 755

(R. 1062 SERVICE) { (a) † 9 844 033
 (b) † 9 844 032
 (23)

(R. 1062 SERVICE) † 9 844 035
 (e)

(c) { † 9 844 011
 † 9 844 026
 (d) † 9 844 029
 (15)

(c) 8 535 810
 (f) 8 543 994
 (1)

† 6 033 897
 6 065 247

6 031 511
 1080 160856
 8 241 707
 (13)

8 515 901
 (9)
 (7)

(12)
 (22)
 (6)

(8)
 (10)
 (21)

1023 060256
 (11)

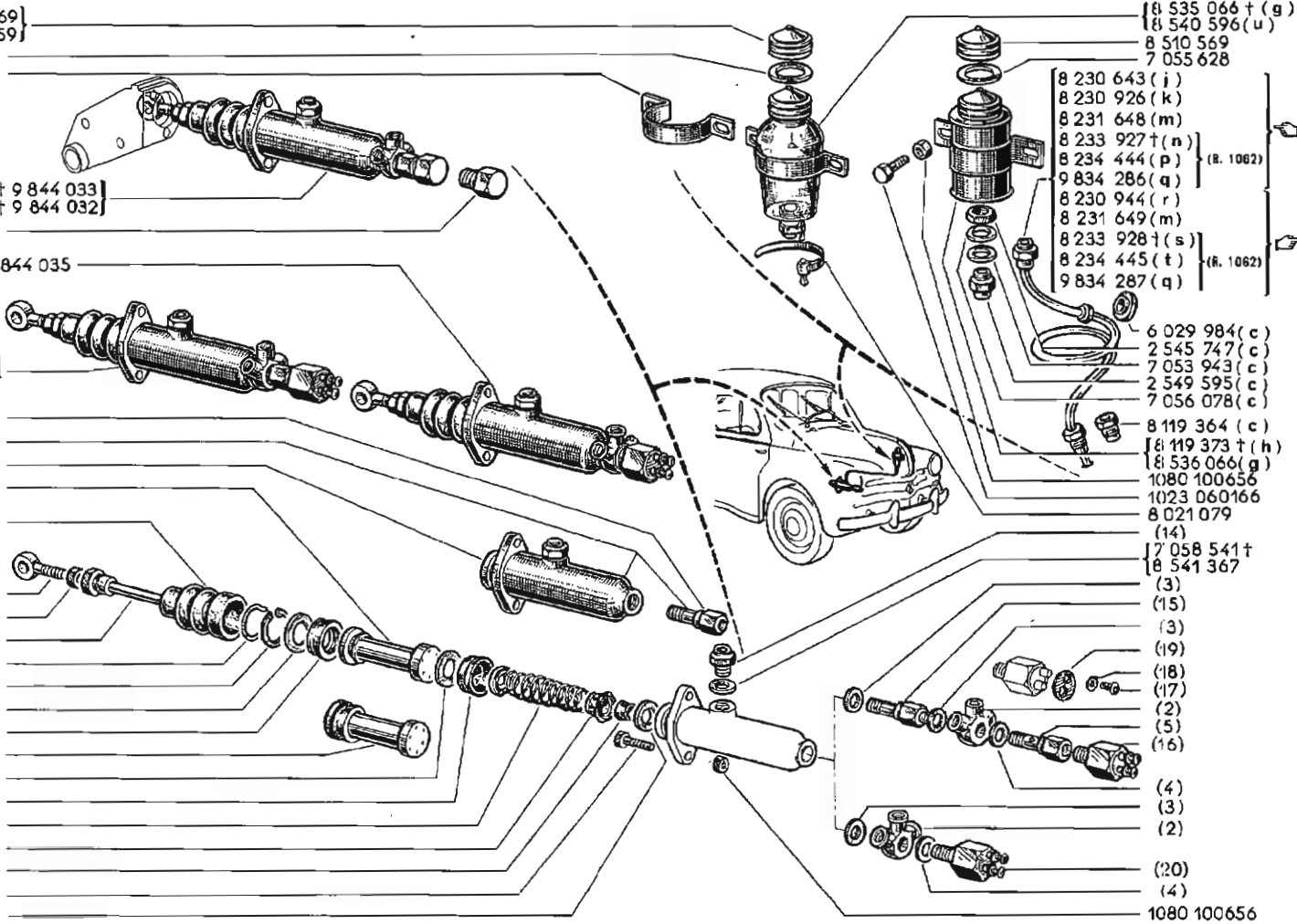

58.71

A P.R. 685

{ 8 535 066 † (g)
 8 540 596 (u)
 8 510 569
 7 055 628

8 230 643 (j)
 8 230 926 (k)
 8 231 648 (m)
 8 233 927 † (n)
 8 234 444 (p) (R. 1062)
 9 834 286 (q)
 8 230 944 (r)
 8 231 649 (m)
 8 233 928 † (s)
 8 234 445 (t) (R. 1062)
 9 834 287 (q)

6 029 984 (c)
 2 545 747 (c)
 7 053 943 (c)
 2 549 595 (c)
 7 056 078 (c)

8 119 364 (c)
 { 8 119 373 † (h)
 8 535 066 (g)
 1080 100656
 1023 060166
 8 021 079
 (14)

{ 7 058 541 †
 8 541 367

(3)
 (15)
 (3)

(19)
 (18)
 (17)

(2)
 (5)
 (16)

(4)
 (3)
 (2)

(20)
 (4)
 1080 100656

	9844033	9844032	9844011	9844026	9844029	9844035	8535810	8543994
(1)	5529593 †	5537988 †	5525669	5529593 †	5537988 †	5537988 †		
(2)	5527436	5526766	5526019	5527436	5526766	6051555		
(3)	7058542	7059611	7058619	7058542	7059611	7053943	7053943	
(4)	7058542	7058619	7058619	7058542	7058619	7053944		
(5)	5527441	5530202	5527441	5527441	5530202			
(6)	5529592	5529592	5525699	5529592	5529592	5529592	5529592	5529592
(7)	5529590 †	5529590 †	5525666	5529590 †	5529590 †	5529590 †		
	5546003	5546003		5546003	5546003	5546003	5546003	5546003
(8)	8241105 †	8241105 †	8240276	8241105 †	8241105 †	8241105 †	8541610	8541610
	6044063	6044063		6044063	6044063	6044063		
(9)	7059450	7059450	7058539	7059450	7059450	7059450	7059450	7059450
(10)	9844027 †	9844027 †	8513189	9844027 †	9844027 †	9844027 †	8542836	8541827
	8542836	8542836		8542836	8542836	8542836		
(11)	6038617	6038617	7058935	6038617	6038617	6038617	6038617	8544109
(12)	8543225 †	8543225 †		8543225 †	8543225 †	8543225 †	8542837 †	8543225 †
	8545895	8545895		8545895	8545895	8545895	8543225 †	8545895
							8545895	
(13)			6034055					8541828
(14)	6034000 †	6043029 †	6034000 †	6034000 †	6043029 †	6043029 †		
	6043029 †	8541368	6043029 †	6043029 †	8541368	8541368		
	8541368		8541368	8541368				
(15)							8542880	
(16)			8231505	8231505	8231505			
(17)			1070 040062	1070 040062	1070 040062	1070 040062		
(18)			1081 300456	1081 300456	1081 300456	1081 300456		
(19)			6037336	6037336	6037336	6037336		
(20)						8234665		
(21)			6033895					
(22)			7058538					
(23)	6048312	6048312						

XXXX 00000	
3	08-00
4	08-00
17	08-00
64	08-00
65	08-00
92	08-00
93	08-00

	XXXX 00000	XXXX 00000	!!!
(m) R.1062			85 3 17
R.2071	4241 VEH		
(n)	257497 VEH	385646	17
(p)	257497 VEH 385801 VEH	385646 385932	17
(q)	385647 VEH 385933 VEH	385800 ...	
(r) R.1060 R.2070 R.1062	1 VEH	251339	4 64
R.2071	1 VEH	4240	
(s)	257497 VEH	385646	
(t)	257497 VEH 385801 VEH	386646 385932	
(u) R.1060 R.2070 R.2071 R.1062 AFFAIRES R.1062 SPORT	924875 VEH 924723 VEH	92 93
(v) R.1060 R.2070 R.2071 R.1062 AFFAIRES R.1062 SPORT	1 VEH 1 VEH	924874 924722	92 93
(w) AFFAIRES SPORT	924875 VEH 924723 VEH	92 93



XXXX 00000	
3	👁️ < 08-00
4	👁️ < 08-00
18	👁️ < 08-00
64	👁️ < 08-00
92	👁️ < 08-00
93	👁️ < 08-00

	n°...	n°...	⚡	⚡	!!!
(a)	1 VEH	252105	3	18	
(b)	252106 VEH	542581	18	3	
(c)	R.1060 R.2070 R.1062 R.2071	1 VEH 1 VEH 252105 4240	4	3	
(d)	R.1062 R.2071	252106 VEH 4241 VEH	3	4	
(e)	R.1062 R.2071	252106 VEH 4241 VEH	3	4	
(f)	R.1062 R.2071	252106 VEH 4241 VEH	3	4	
(g)	R.1062 R.1062 AFFAIRES R.1062 SPORT R.1060 R.2070 R.2071	385647 VEH 385933 VEH 385933 VEH R.1060 R.2070 R.2071	385800 924674 924722	92 93	
(h)	R.1060 R.2070 R.2071 R.1062 R.1062	1 VEH 385801 VEH 385646 385932			
(j)	R.1060 R.2070	1 VEH 1 VEH	8830 1408		
(k)	R.1060 R.1062 R.2070 R.2071	8831 VEH 1 VEH 1408 VEH 1 VEH	251339 4 64	3	



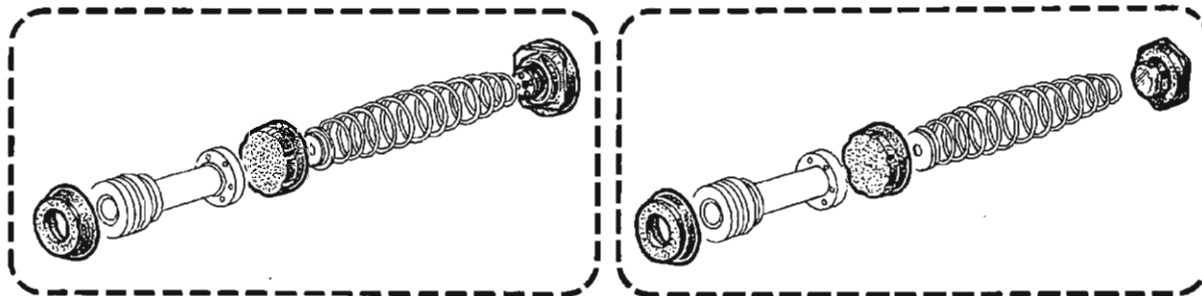

(b)(R. 1062) 8 543 970

(b)(R. 1082) 8 543 993

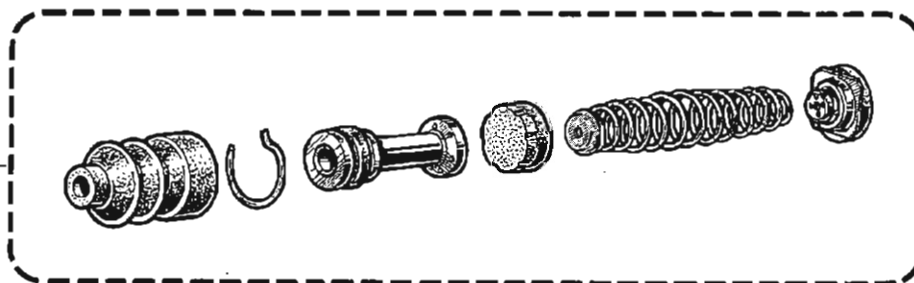

8 541 491 { (R. 1080) (R. 2070) (R. 2071) (R. 1062) (a)

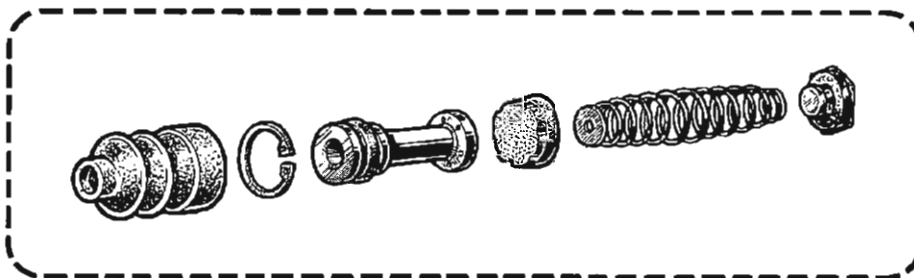

8 541 490 { (R. 1080) (R. 2070) (R. 2071) (R. 1062) (a)

(a) VEH n° 1 ⇨ VEH n° 863714
(b) VEH n° 863715 ⇨ VEH n° ...

(e)(R. 1062) 8 543 916

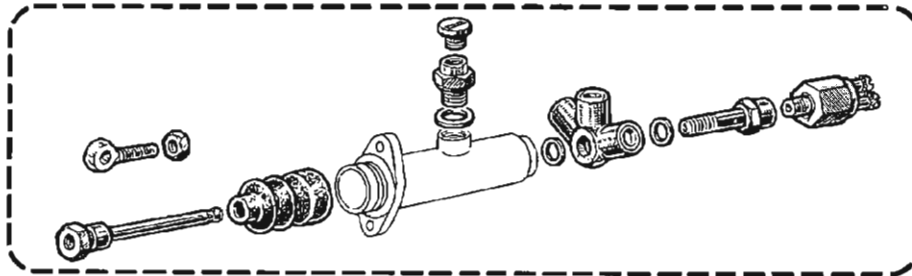
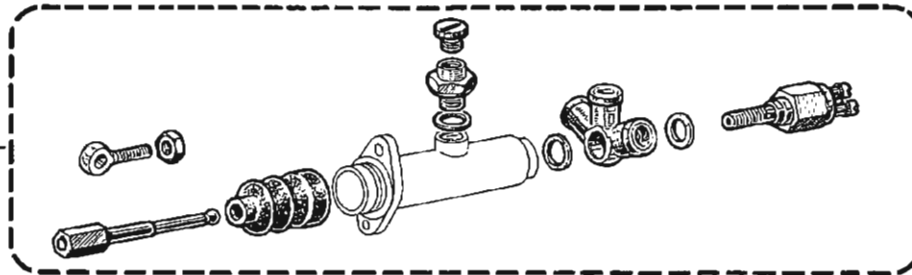

8 541 620 { (R. 1060)(R. 2070)
(R. 1052)(a)
(R. 2071)(b)

{ (c)(R. 1062)
(d)(R. 2071) } 8 542 881

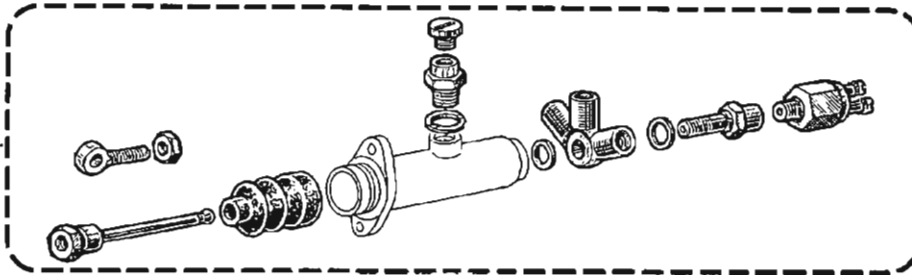

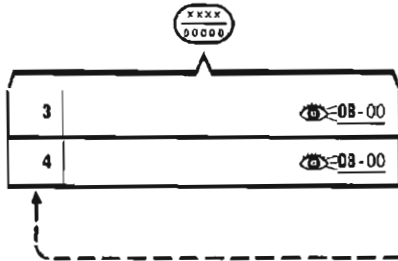

	n°...	n°...	!!!
(a)	1 VEH	252105	4 3
(b)	1 VEH	4240	
(c)	252106 VEH	542581	
(d)	4241 VEH	...	
(e)	542582 VEH	863714	

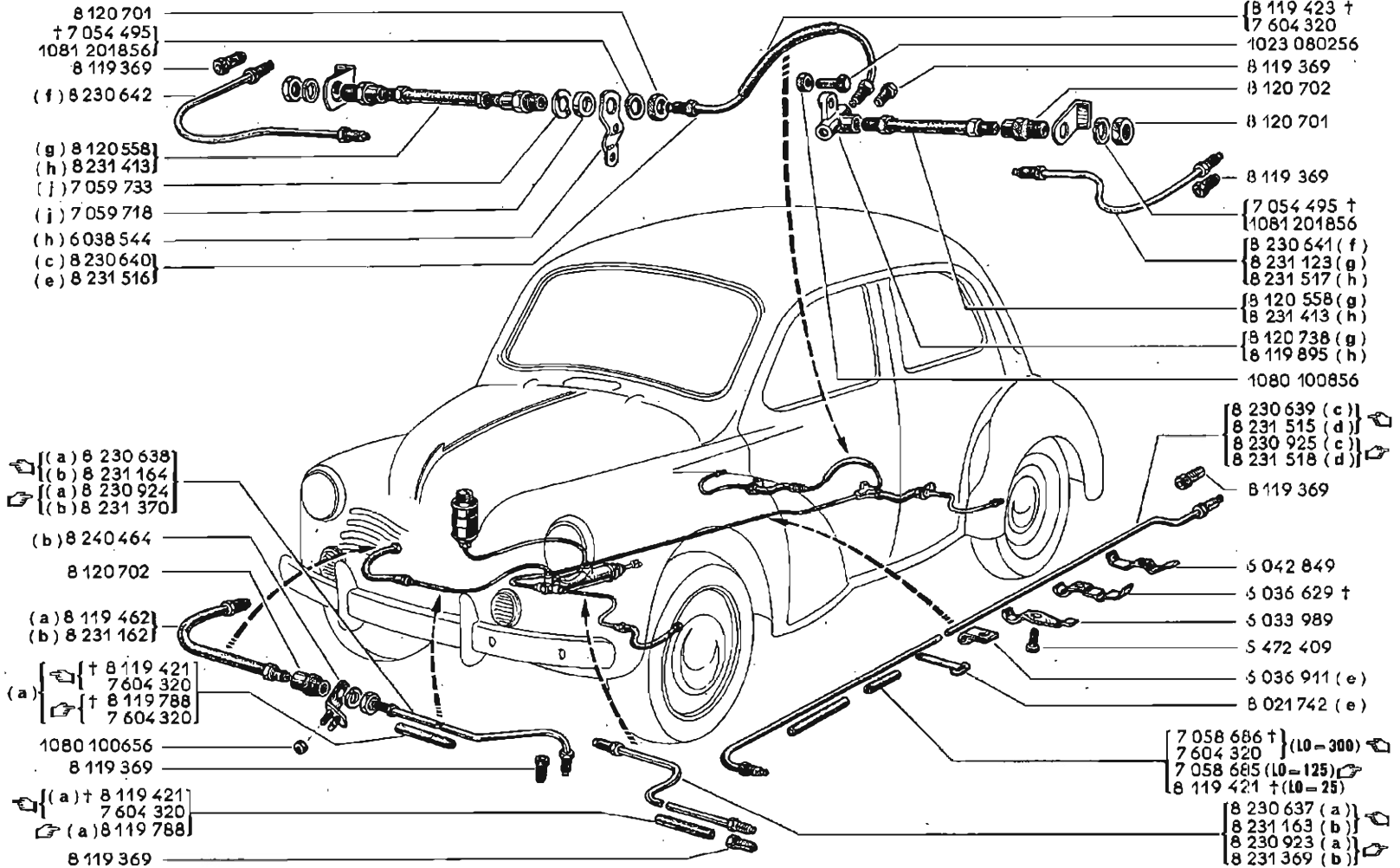

XXXX
00000

19	08-00
67	08-00
80	08-00

	n°...	☐	n°...	⚡	⚡	!!!
(a) R.1060	1 VEH		51276	19	67	
R.2070	1 VEH		6374		80	
(b) R.1080	51277 VEH		...	67	19	
R.2070	6375 VEH		...	80		
(c) R.1080	1 VEH		89689			
R.2070	1 VEH		9513			
(d) R.1060	89690 VEH		...			111
R.2070						111
(e) R.1060	89690 VEH		...			
R.2070	9514 VEH		...			
(f) R.1060	1 VEH		52273			
R.2070	1 VEH		6473			
(g) R.1060	52274 VEH		89689			
R.2070	6474 VEH		9513			
(h) R.1080	89690 VEH		...			
R.2070	9514 VEH		...			
(j) R.1060	111938 VEH		...			
R.2070	10149 VEH		...			



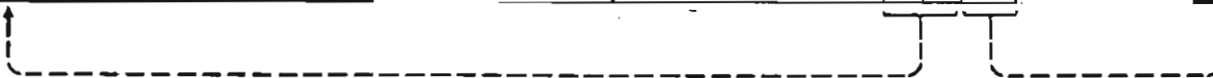

!!!

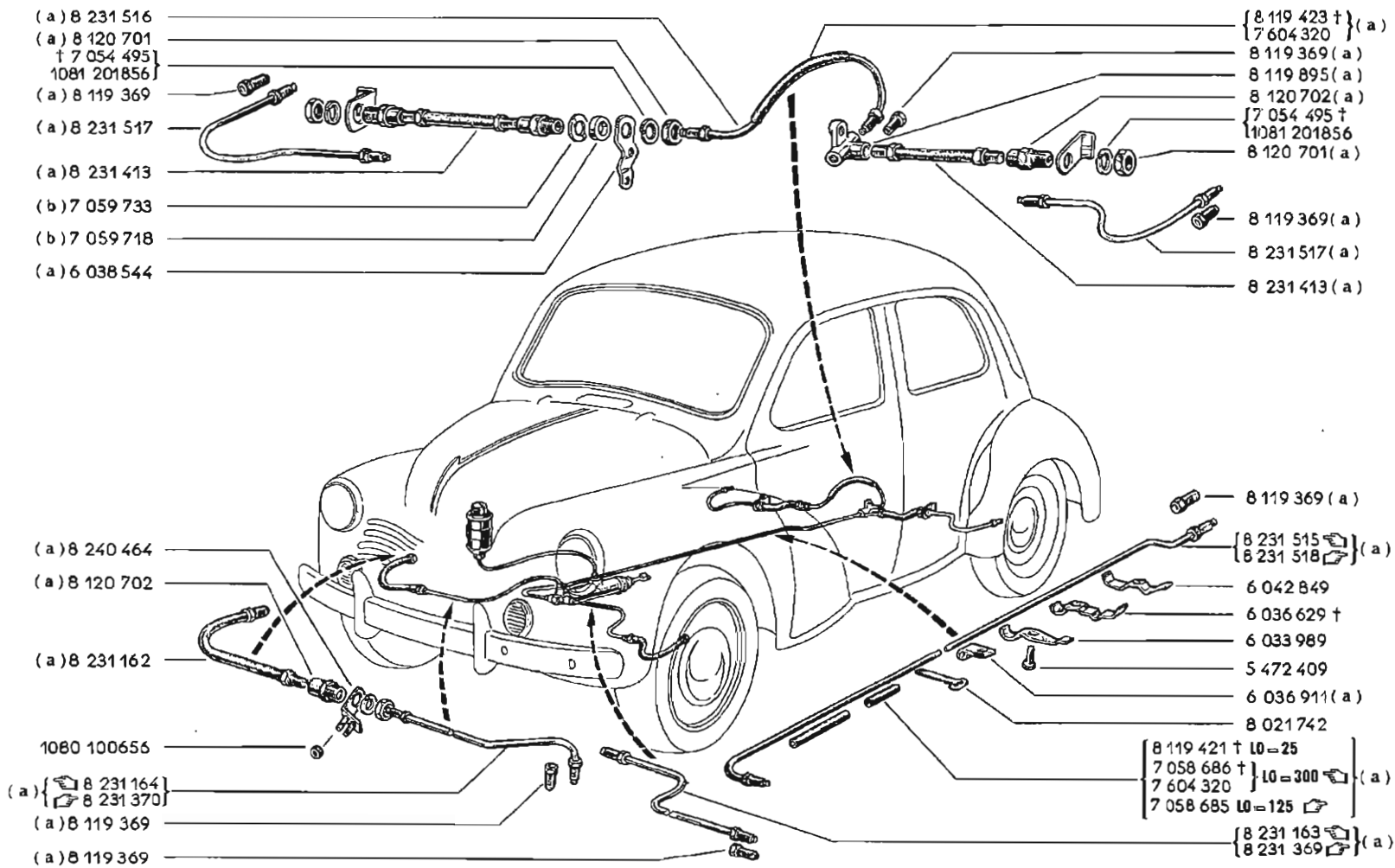
111		6036911 -f- 8021742 -f-
-----	--	----------------------------









XXXX
00000

1	 08-00
2	 08-00
3	 08-00
4	 08-00

XXXX
00000

	n°...	⇨	n°...				
(a) { R.1062 R.2071				4	3		
(b) { R.1062 R.2071	1 VEH		69929	2	1		
	1 VEH		2524				



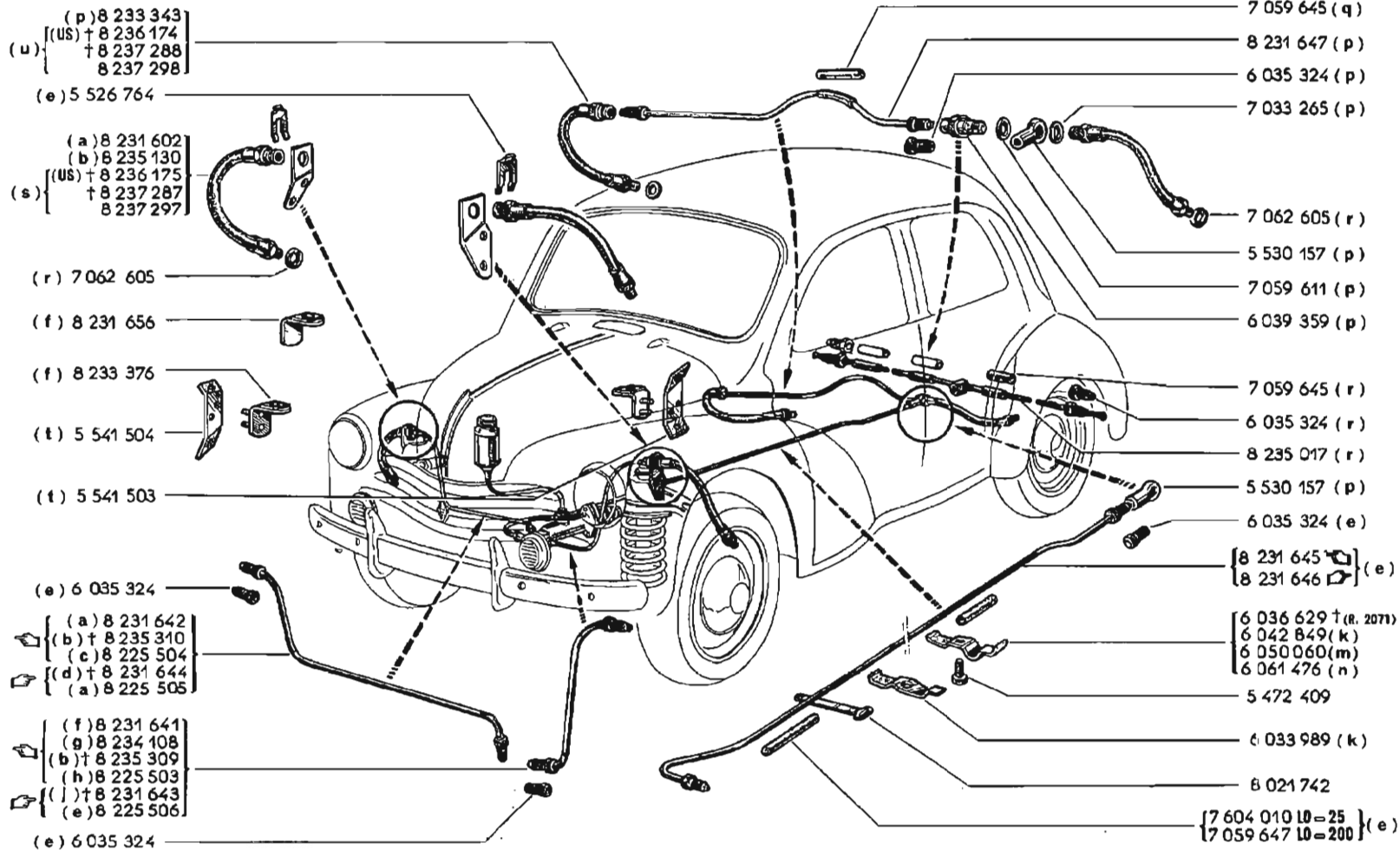

XXXX
00000

3	08-00
4	08-00
9	08-00
29	08-00
34	08-00
35	08-00

	n°...	n°...	XXX 0000	!!!
(a) R.1062	252106 VEH	484678	3	4
R.2071			29	
(b) R.1062	484679 VEH	634187	35	34
(c) R.1062			29	
(d) R.1062	252106 VEH	634187	35	34
(e) R.1062			3	4
R.2071				
(f) R.1062	252106 VEH	354452	3	4
(g) R.1062	354453 VEH	484678	9	29
R.2071				
(h) R.1062	484679 VEH	...	29	
(j) R.1062			3	4
(k) R.1062	252106 VEH	283715		
R.2071				
(m) R.1062	283716 VEH	734970		
(n) R.1062	734971 VEH	...		
(p) R.1062	252106 VEH	634187	3	4
R.2071			35	34
(q) R.1062			3	4
R.2071			35	34
(r) R.1062	634188 VEH	...	34	35
(s) R.1062	634188 VEH	...	34	35
(t) R.1062	252106 VEH	352452		288
(u) R.1062	634188 VEH	...	34	35
				280

!!!

288	+	8237297
290	+	8237288

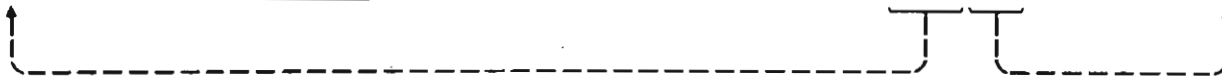

62.01

A P.R. 685

(R. 1060) (R. 2070) 8 511 124

† 8 506 779
8 543 716

(161) 8 516 164

(R. 1060, R. 1062 US) 8 516 605

(R. 1060, R. 1062 ↓) 8 516 604

(a) 5523 976
(b) }
(c) }
(d) } 5529 274

8 516 289
8 516 208

† 8 516 288
8 543 712

8 543 712

8 516 287

8 543 713

8 537 732

(a) { R 1060 CAR n° 1 ⇨ CAR n° 80265
{ R 2070 CAR n° 1 ⇨ CAR n° 9339
(b) { R 1060 CAR n° 1 ⇨ CAR n° 5633
{ R 2070 CAR n° 1 ⇨ CAR n° 64

(c) { R 1060 CAR n° 80266 ⇨ CAR n° ...
{ R 2070 CAR n° 9340 ⇨ CAR n° ...
(d) { R 1060 CAR n° 5634 ⇨ CAR n° ...
{ R 2070 CAR n° 65 ⇨ CAR n° ...

C19) 100-00
C20)

161 06-00

62.01

A P.R. 685

8 512 863

8 512 870

8 506 761

8 512 865

8 511 095

8 512 765

{ 8 512 867 †
{ 8 537 729

(R. 1060)
(R. 2070)

8 512 794

8 512 868

1081 300556

{ 7 058 416 †
{ 1072 850129

8 544 381

8 516 210

8 516 209

8 516 262

8 516 263

8 516 145 †

8 510 581

{ 8 511 491 (C18)
{ 8 028 017 ↓ (C20)

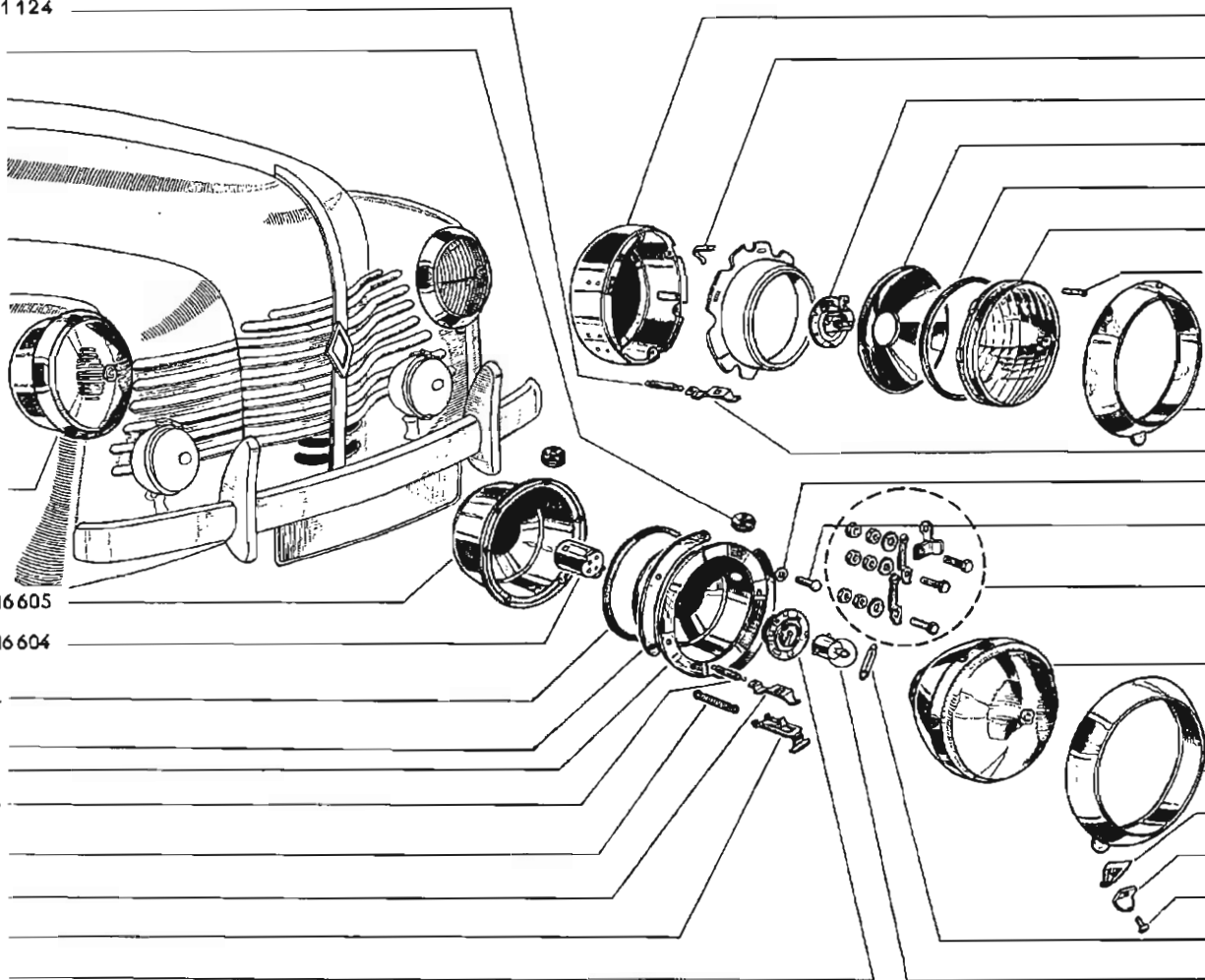

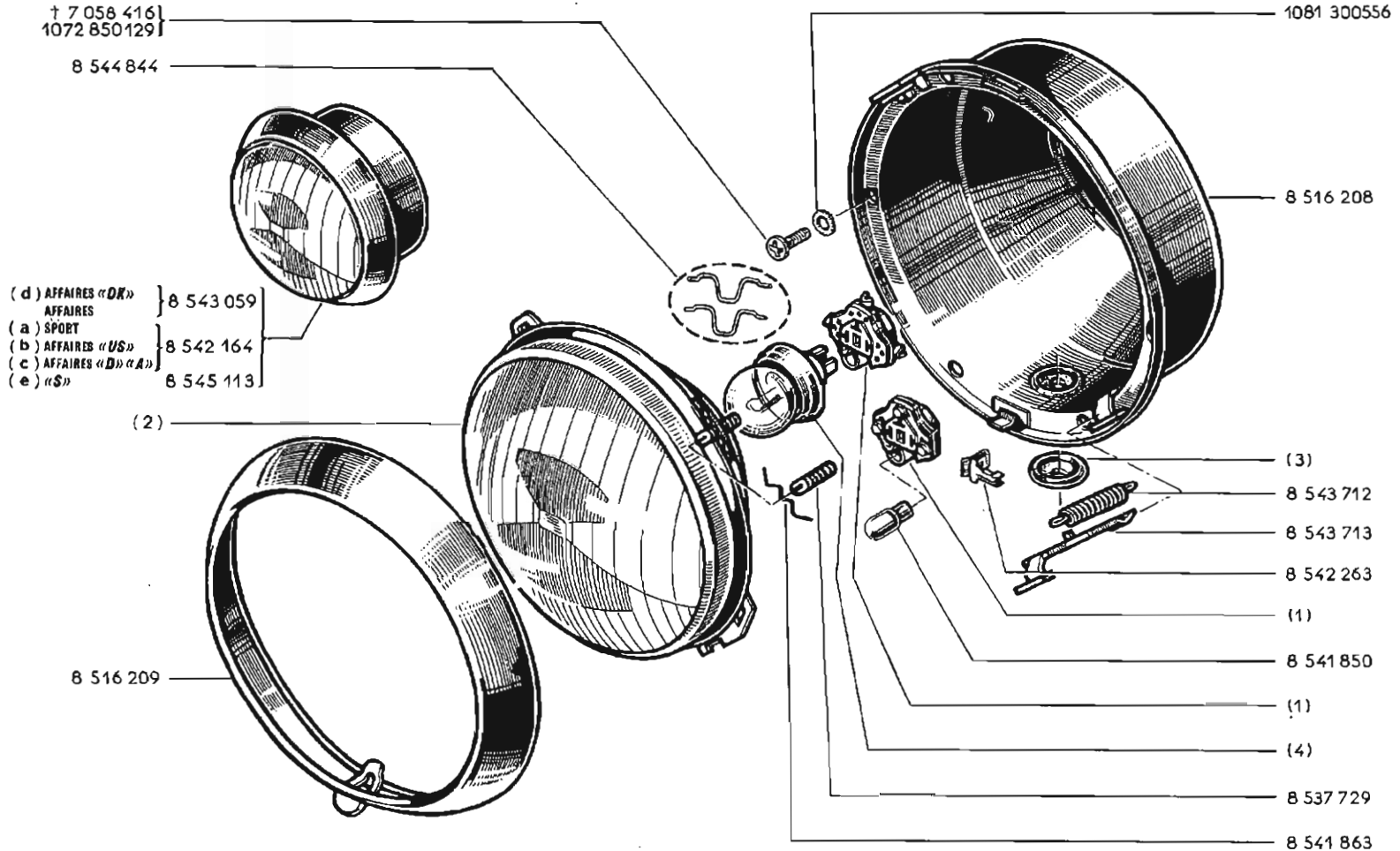

	8543059	8542164	8543113
(1)	8543102	8542398	8542398
(2)	8542165 †	8542165 †	—
	8544904	8544904	8544904
(3)	8506779 †	8506779 †	—
	8543716	8543716	8543716
(4)	8541539	8541539	—
	8541844 ⚓	8541844 ⚓	8541844

- (a) VEH n° 869051 ⇔ VEH n° 880289
- (b) VEH n° 869016 ⇔ VEH n° ...
- (c) VEH n° 880290 ⇔ VEH n° ...
- (d) VEH n° 904447 ⇔ VEH n° ...
- (e) VEH n° 904187 ⇔ VEH n° ...

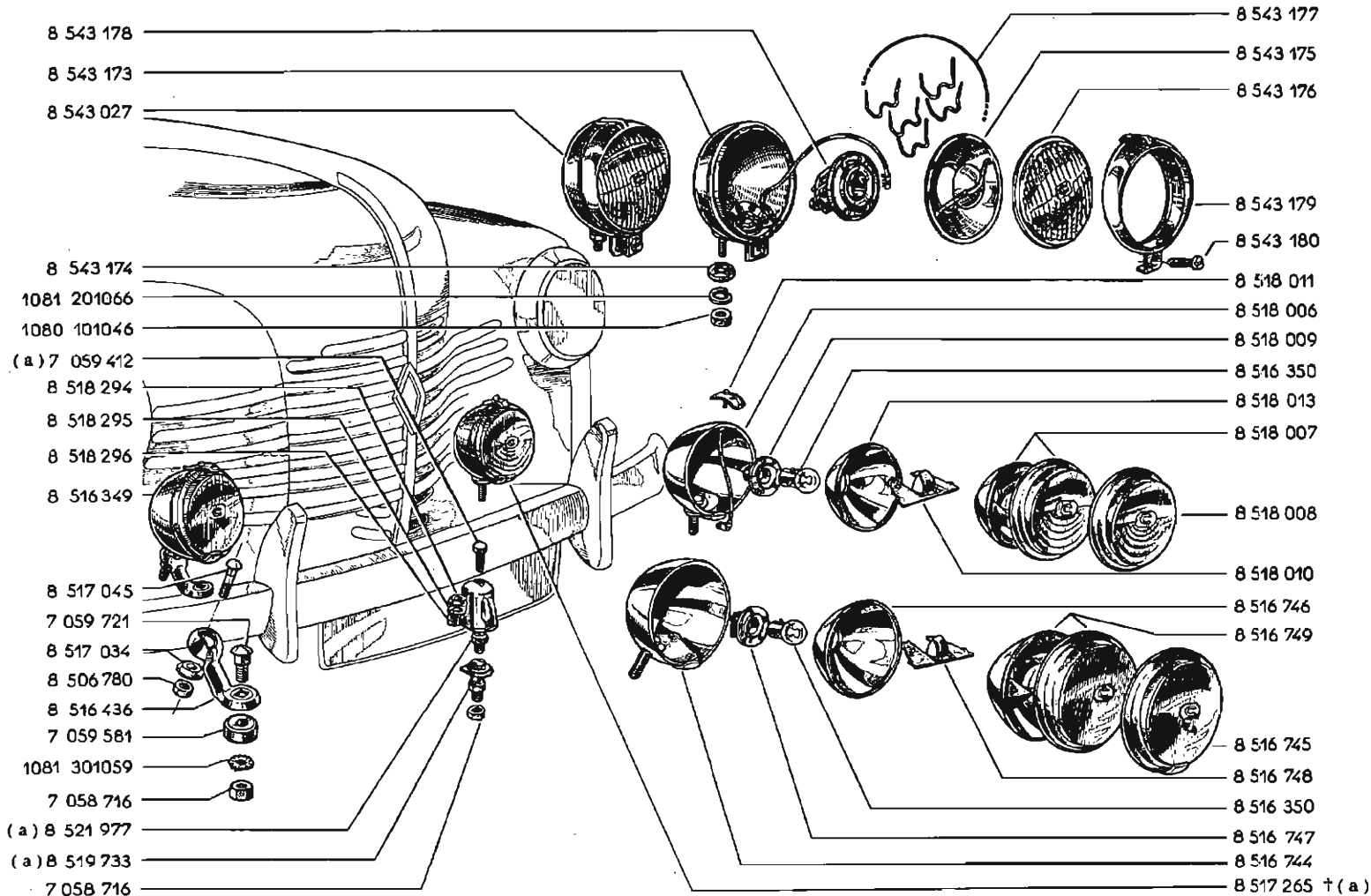

(a) { R 1060 { VEH n° 1 ⇨ VEH n° 405209
 R 1062 { VEH n° 405601 ⇨ VEH n° 406426

(R. 1082) «US» «CN» 8 535 166 }
(e) 8 028 022 }

(d) 8 021 014

8 518 460

8 544 834

8 516 069

8 544 833

8 518 461

1081 310559

1080 100550

8 516 073

8 544 748

1080 120440

8 545 120

8 544 748

1080 120440

8 544 833

8 544 834

8 545 121

8 518 462

8 517 774 (a)
8 535 671 (b) AFFAIRES

8 518 459

8 516 071

8 518 463

8 517 773 (c)
8 535 672 (b) 

8 516 075

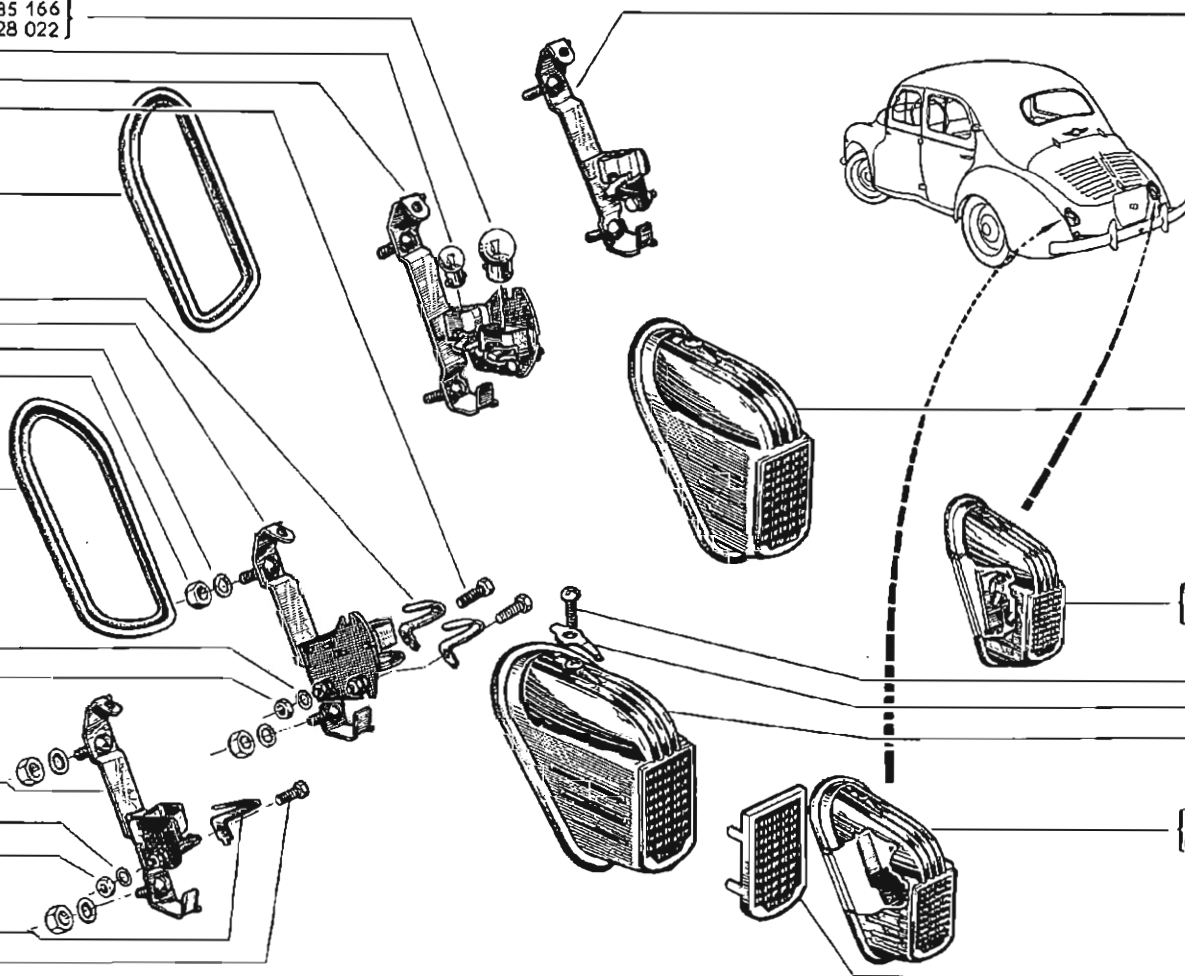

32	Ⓢ08-00
66	Ⓢ08-00

	n°...	n°...	!!!	!!!
(a) R.1060	1 VEH	64484		162
R.1062	1 VEH	532892	32	162
(b) R.1062	432707 VEH	532892	32	66
(c) R.1060	64484 VEH	...		162
R.1062 SPORT	1 VEH	532892	32	162
R.1062 AFFAIRES	1 VEH	532892	32	162
R.2070	8013 VEH	...		162
R.2071		162
(d) R.1060	64484 VEH	...		
R.1062	1 VEH	532892		
R.2071	1 VEH	532892		
R.2070	8013 VEH	...		
(e) R.1060	64484 VEH	...	32	
R.1062	1 VEH	532892		
R.2070	8013 VEH	...		
R.2071		

162	Ⓢ08-00
-----	--------



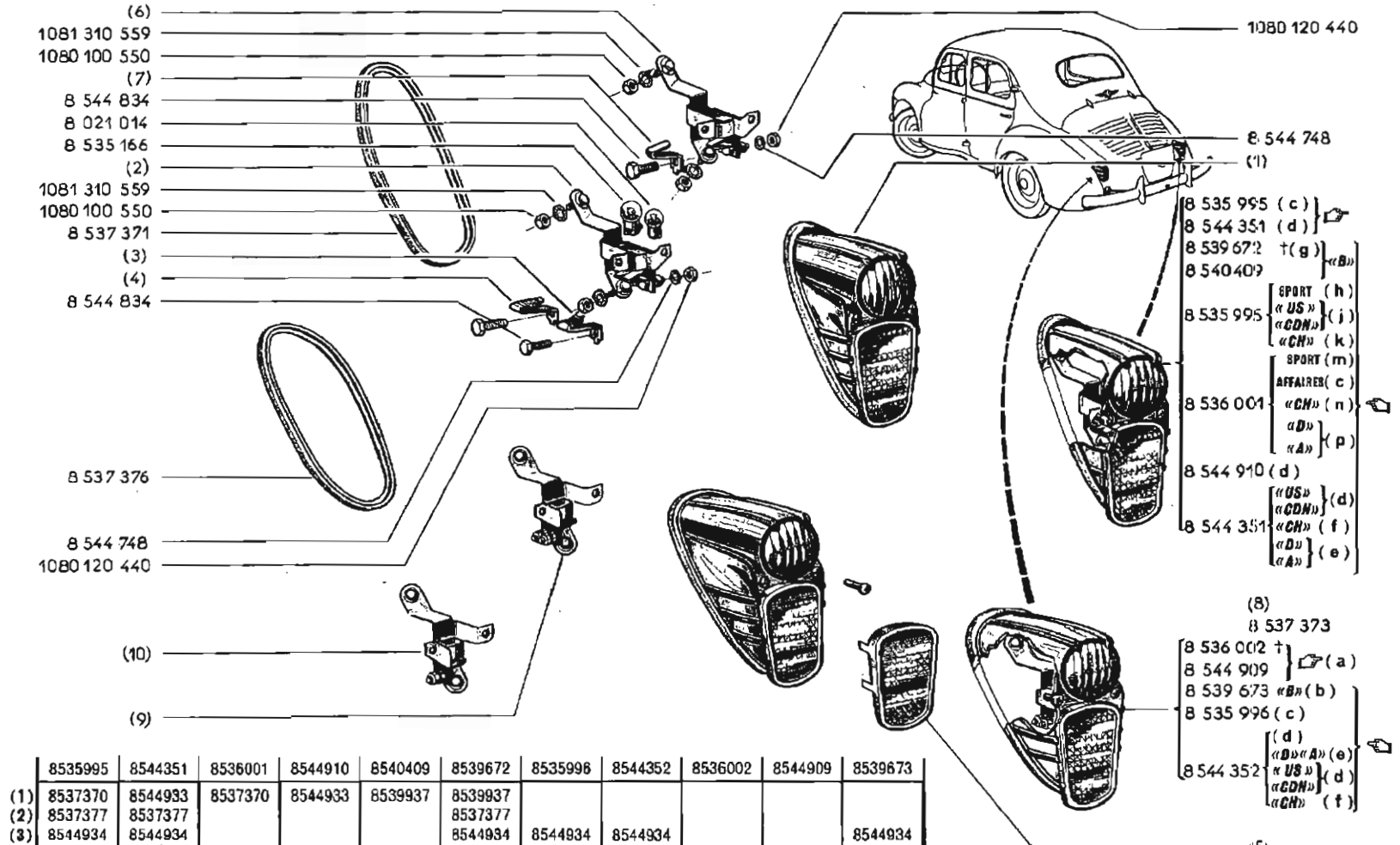

	8535995	8544351	8536001	8544910	8540409	8539672	8535996	8544352	8536002	8544909	8539673
(1)	8537370	8544933	8537370	8544933	8539937	8539937					
(2)	8537377	8537377			8539937	8537377					
(3)	8544934	8544934			8544934	8544934	8544934	8544934			8544934
(4)	8544935	8544935			8544935	8544935	8544935	8544935			8544935
(5)	8539938	8544832	8545945	8544832	8539938	8539938	8545945	8544832	8545945	8544832	8539938
(6)			8537369	8537369	8537369						
(7)			8544833	8544833	8544833						
(8)						8537375	8544936	8544833	8544833	8544833	8539939
(9)						8537378	8537378	8537375	8544936	8544936	8539939
(10)								8537374	8537374	8537374	8537378

- 1080 120 440
- 8 544 748
- (1)
- 8 535 995 (c)
- 8 544 351 (d)
- 8 539 672 †(g)
- 8 540 409 «B»
- 8 535 995 [SPORT (h) «US» (i) «CDN» (j) «CH» (k)]
- 8 536 001 [SPORT (m) AFFAIRE (c) «CH» (n) «D» (p) «A»]
- 8 544 910 (d)
- 8 544 351 [«US» (d) «CDN» (f) «D» (e) «A»]
- (8)
- 8 537 373
- 8 536 002 †
- 8 544 909 (a)
- 8 539 673 «B» (b)
- 8 535 996 (c)
- 8 544 352 [(d) «D» «A» (e) «US» (d) «CDN» (f) «CH»]
- (5)

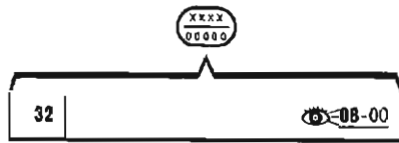

	n°...	n°...	!!!
(a)			32
(b)			207
(c)	532893 VEH	891359	32
(d)	891360 VEH	...	
(e)	880290 VEH	...	
(f)	894653 VEH	...	
(g)	532893 VEH	734970	207
(h)	532893 VEH	734970	32
(j)	532893 VEH	891359	
(k)	822462 VEH	894652	
(m)	734971 VEH	891359	
(n)	532893 VEH	822461	
(p)	532893 VEH	880289	



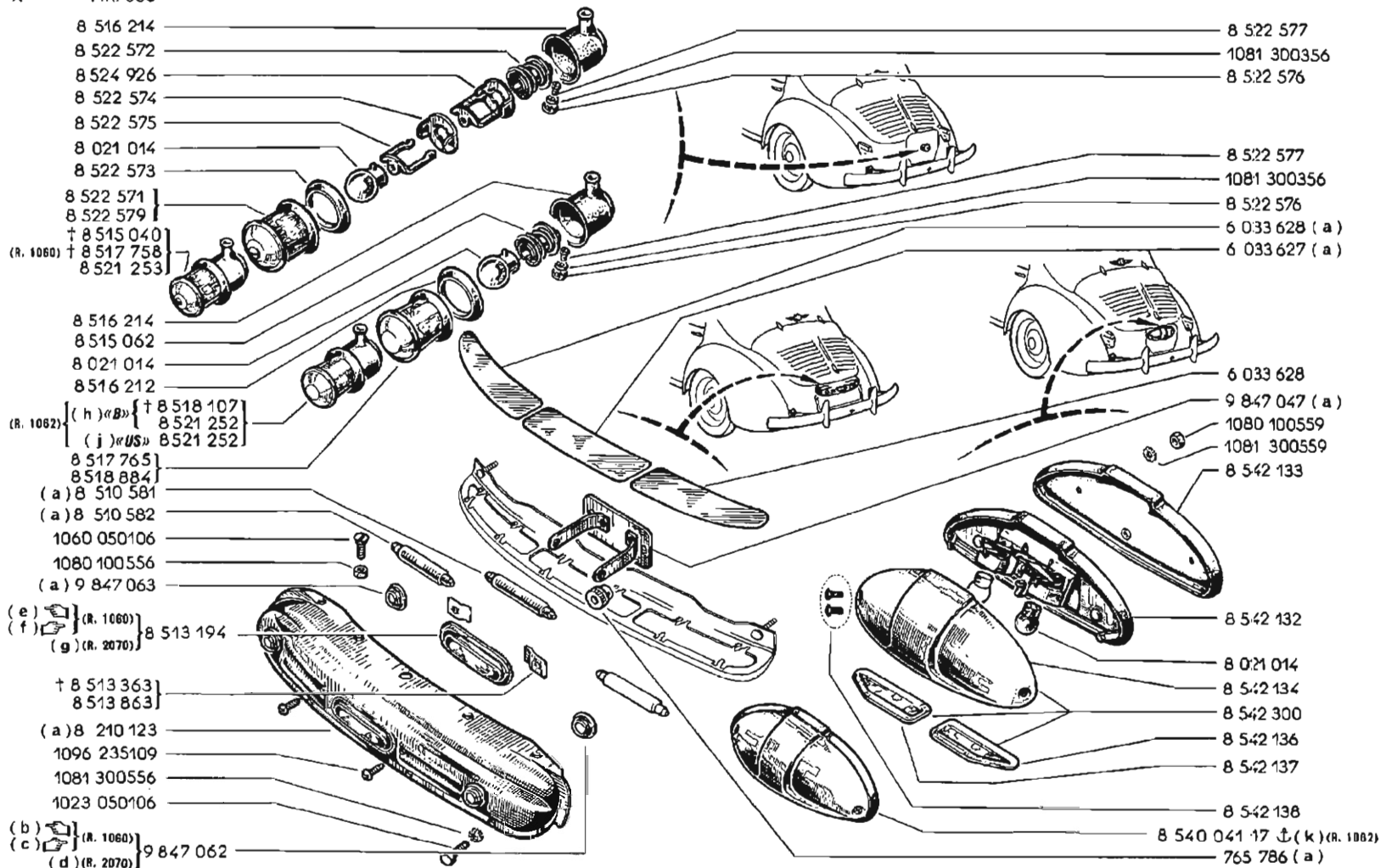

- (a) { R 1060 VEH n° 1 ⇨ VEH n° 64483
R 2070 VEH n° 1 ⇨ VEH n° 8012
- (b) CAR n° 1 ⇨ CAR n° 15189
- (c) CAR n° 1 ⇨ CAR n° 1581
- (d) CAR n° 1 ⇨ CAR n° 2146
- (e) CAR n° 15190 ⇨ VEH n° 64483

- (f) CAR n° 1582 ⇨ VEH n° 64483
- (g) CAR n° 2147 ⇨ VEH n° 8012
- (h) VEH n° 427467 ⇨ VEH n° ...
- (j) VEH n° 88629 ⇨ VEH n° 849592
- (k) VEH n° 849593 ⇨ VEH n° ...

8 512 965

8 512 773

6 037 970

8 513 712

8 513 714

{ 8 506 238 DE=15
8 511 180 DE=11

8 539 586 L0=125

8 512 967 L0=150

8 512 633

8 511 389

8 513 713

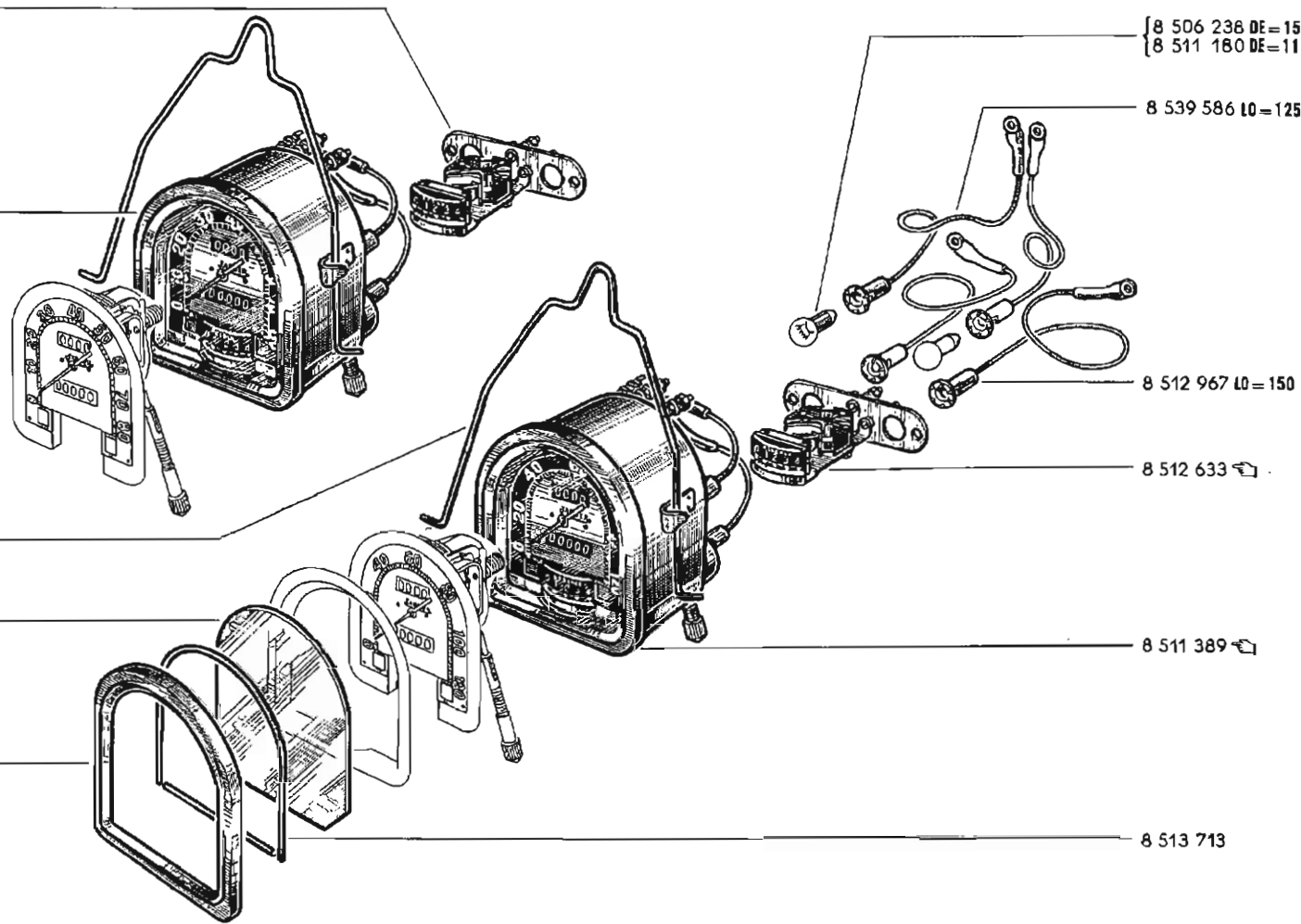

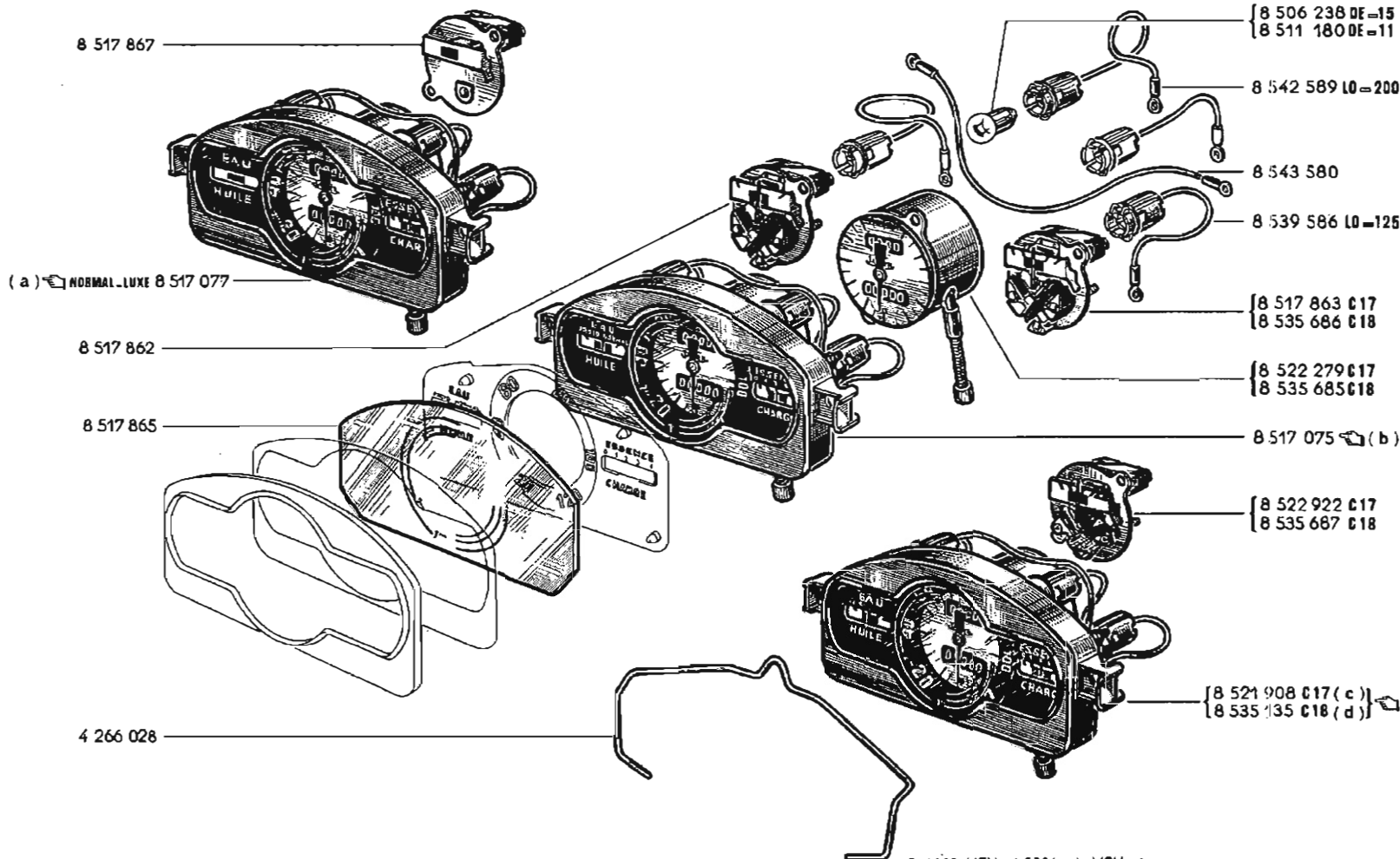

C17] 100-00
C18]

- (a) { R 1062 VEH n° 3531 ⇨ VEH n° ...
R 2071 VEH n° 166 ⇨ VEH n° ...
- (b) VEH n° 5101 ⇨ VEH n° 283715
- (c) { VEH n° 283716 ⇨ VEH n° 405209
VEH n° 405601 ⇨ VEH n° 406426
- (d) { VEH n° 405210 ⇨ VEH n° 405600
VEH n° 406427 ⇨ VEH n° 414002

DE-15 8 506 238 }
DE-11 8 511 180 }

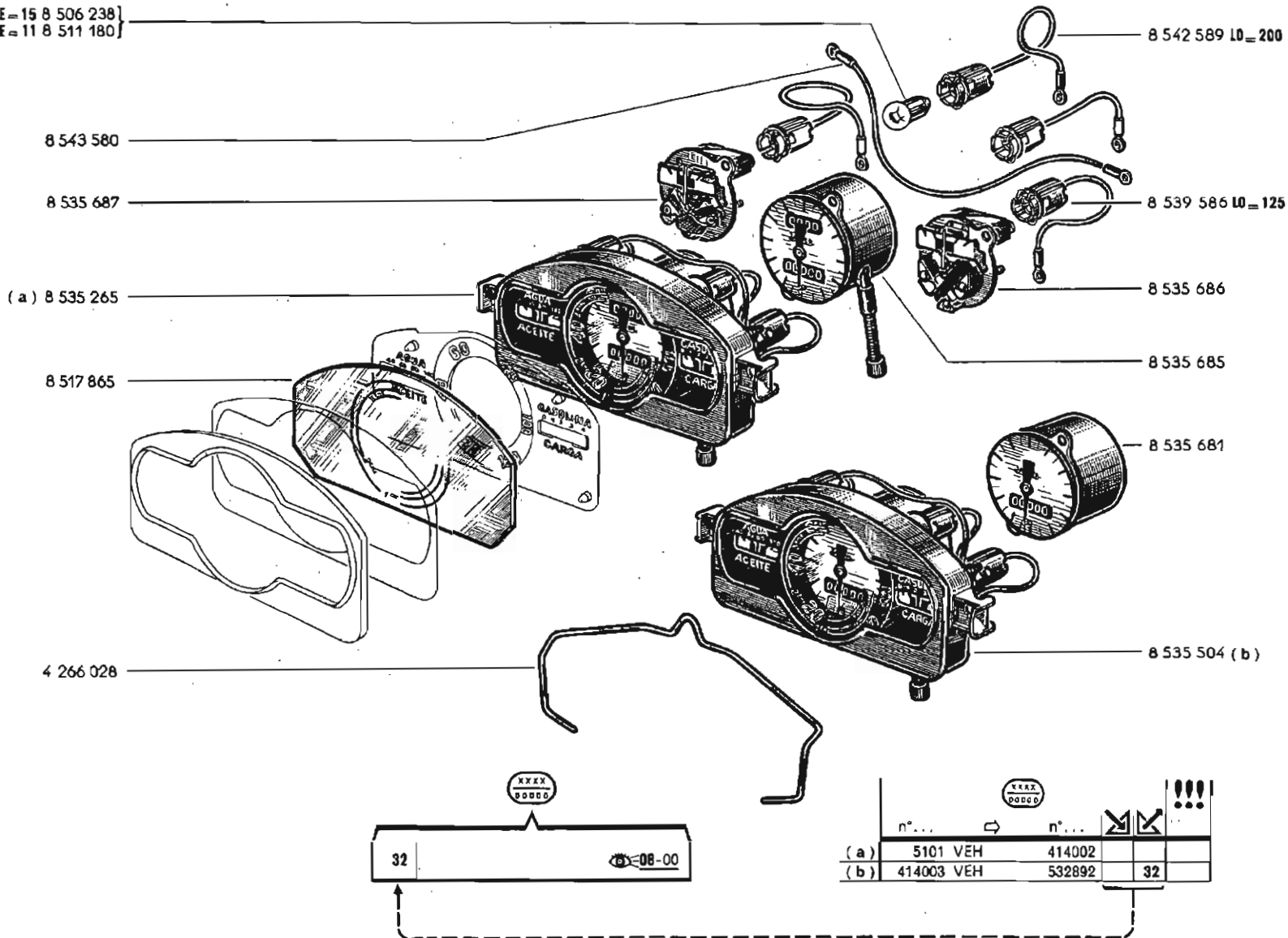

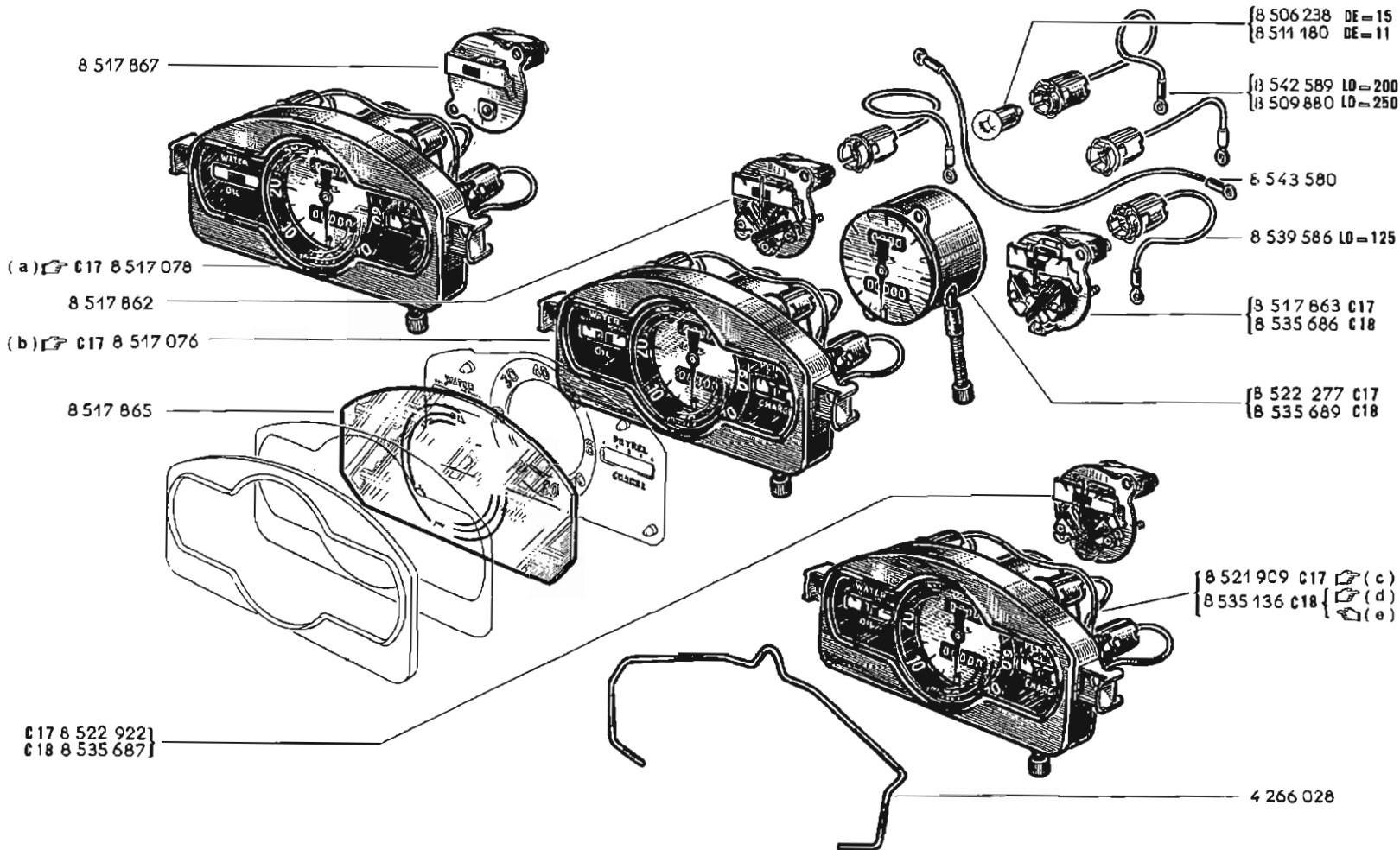

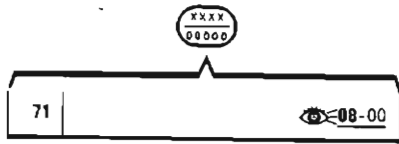

	n°...	⇨	n°...	↖	↗	!!!
(a)	3531 VEH R 1062 ... 166 VEH R 2071 ...				71	
(b)	5101 VEH		283715			
(c)	283716 VEH 405601 VEH		405209 406426			
(d)	405210 VEH 406427 VEH		405600 414002			
(e)	406427 VEH		414002			

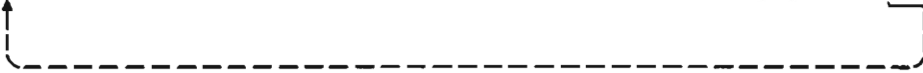

DE=15 8 506 238)
DE=11 8 511 180)

8 543 580

8 535 687

(a) C18 8 535 502

8 517 865

4 266 028

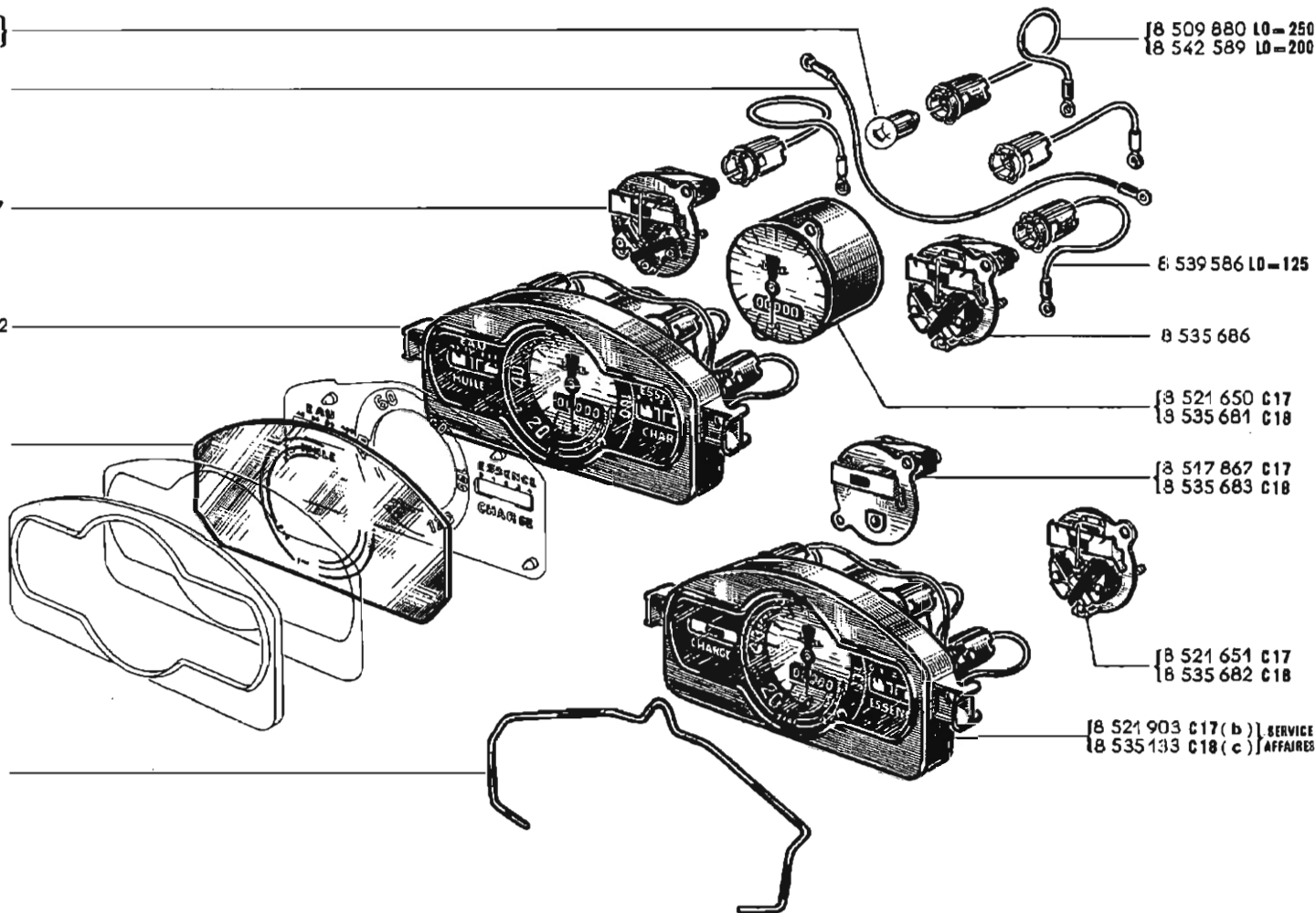

C17) 100-00
C18)

XXXX
00000

32

08-00

	n°...	n°...	!!!
(a)	414003 VEH	532892	32
(b)	1 VEH	405209	
	405601 VEH	406426	
(c)	405210 VEH	405600	
	406427 VEH	532892	32



DE=15 8 506 238
QE=11 8 511 180

{ 8 542 589 10=200
8 509 880 10=250

8 535 687

(a) 8 535 503

8 517 865

C17 8 517 867
C18 8 535 683

4 266 028

8 543 580

8 539 586 10=125

8 535 686

{ 8 524 992 C17
8 535 684 C18

{ 8 521 651 C17
8 535 682 C18

{ 8 523 634 C17 (b)
8 535 134 C18 (c) } AFFAIRES

C17) 100-00
C18)

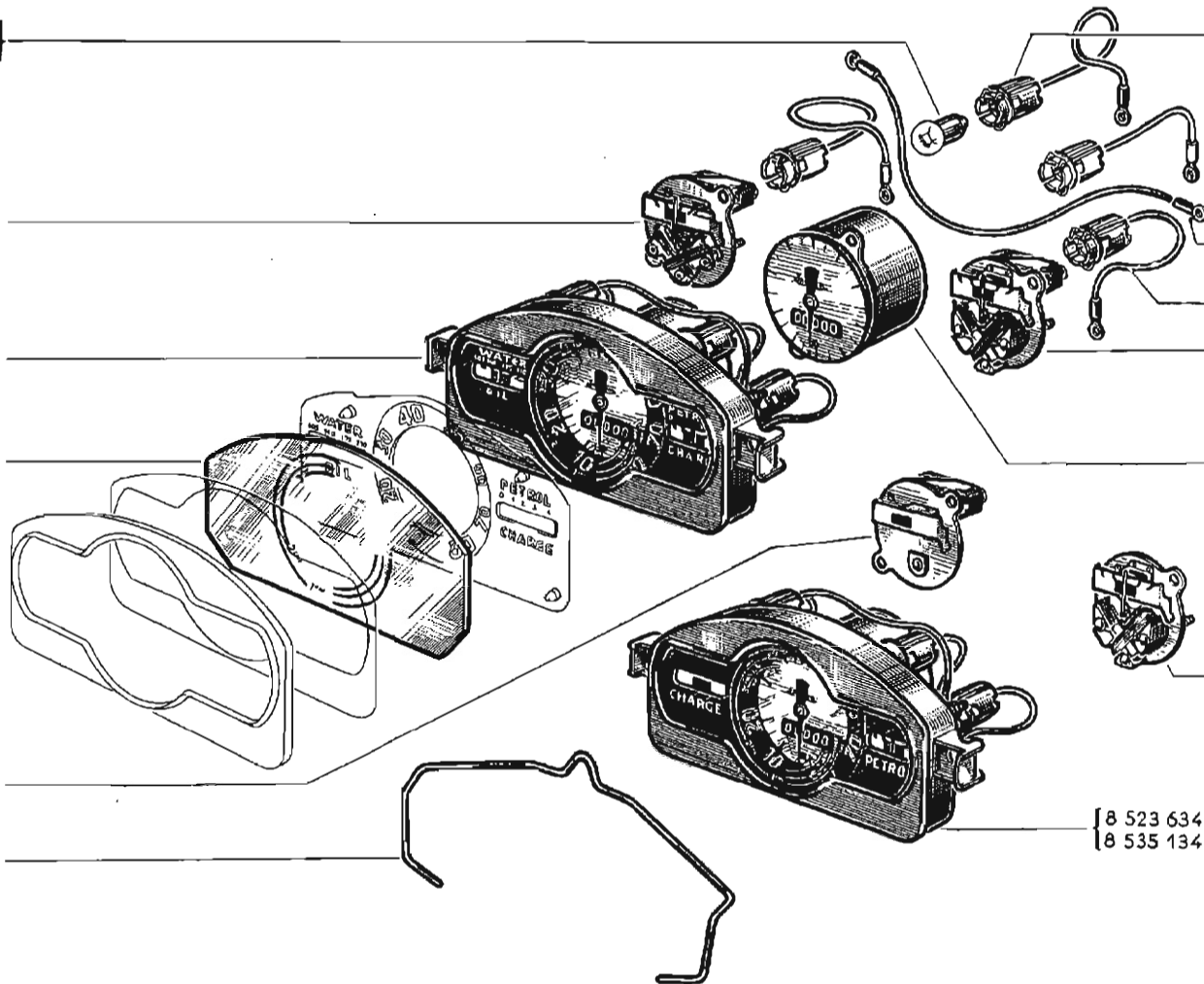

XXXX
00000

32 | 08-00

	n°...	⇨	n°...	↖	↗	!!!
(a)	414003 VEH		532892		32	
(b)	1 VEH		405209			
	405601 VEH		406426			
(c)	405210 VEH		405600			
	406427 VEH		532892		32	

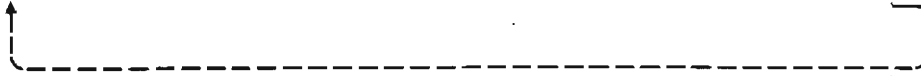

L0=125 8 539 586

- (e) 8 541 444
- (a) 8 536 471
- (c) «DK» 8 544 232
- (d) «CH» 8 544 559
- «GS» { (b) 8 537 764
- (e) 8 541 450
- (a) 8 537 149
- (e) 8 541 449

- 8 537 323
- 8 541 973
- 8 537 325
- 8 537 320

- 8 537 321
- 8 537 611

- 8 541 872
- 8 537 319
- 8 537 320

- 8 537 321
- 8 537 611

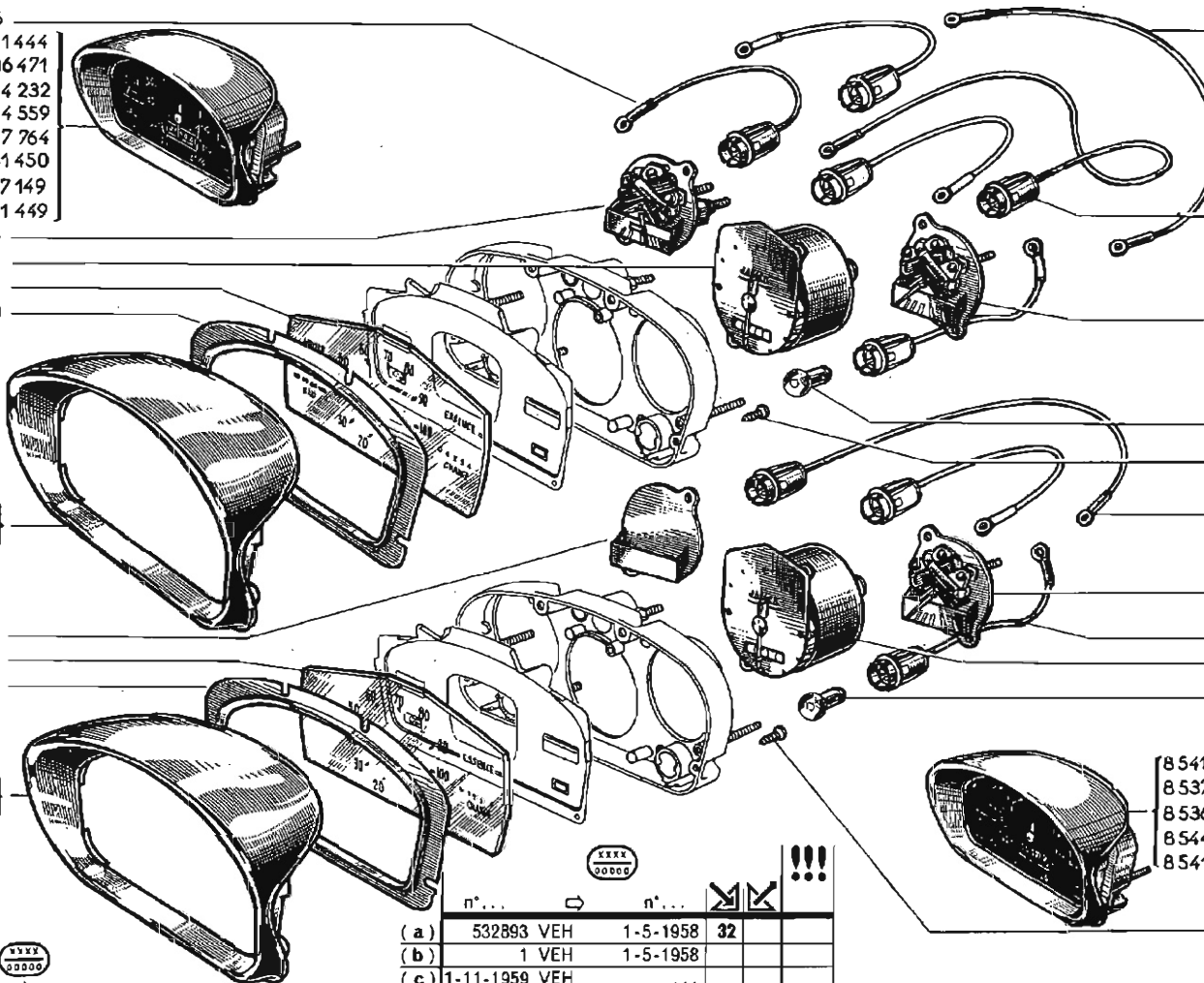

- 8 543 580 L0=170
- 8 545 049 L0=80

- 8 545 048
- 8 541 975 «GS» (e)
- 8 541 974 { «DK»
- (e)

- 8 537 316 (a)
- 8 537 864 «GS» (b)
- 8 545 047 «CH»
- 8 506 238 DE=15
- 8 511 180 DE=11
- 8 544 813

8 542 589 L0=200

- 8 541 974 { «DK»
- (e)
- 8 537 316 (a)
- 8 539 586 L0=125
- 8 541 973
- 8 506 238 DE=14
- 8 511 180 DE=11

- 8 541 443 (e)
- 8 537 143 (a)
- 8 536 469 (a)
- 8 544 231 «DK»
- 8 541 442 (e)

SERVICE
AFFAIRES

8 544 813

n°...	⇨	n°...	↗	↘	!!!
(a)	532893 VEH	1-5-1958	32		
(b)	1 VEH	1-5-1958			
(c)	1-11-1959 VEH	...			
(d)	894652 VEH	...			
(e)	1-6-1958 VEH	...			

LO=125 8 539 586

- (b) 8 541 447
- (a) 8 537 046
- 8 543 184
- 8 545 060
- (a) 8 536 472
- (d) 8 541 445

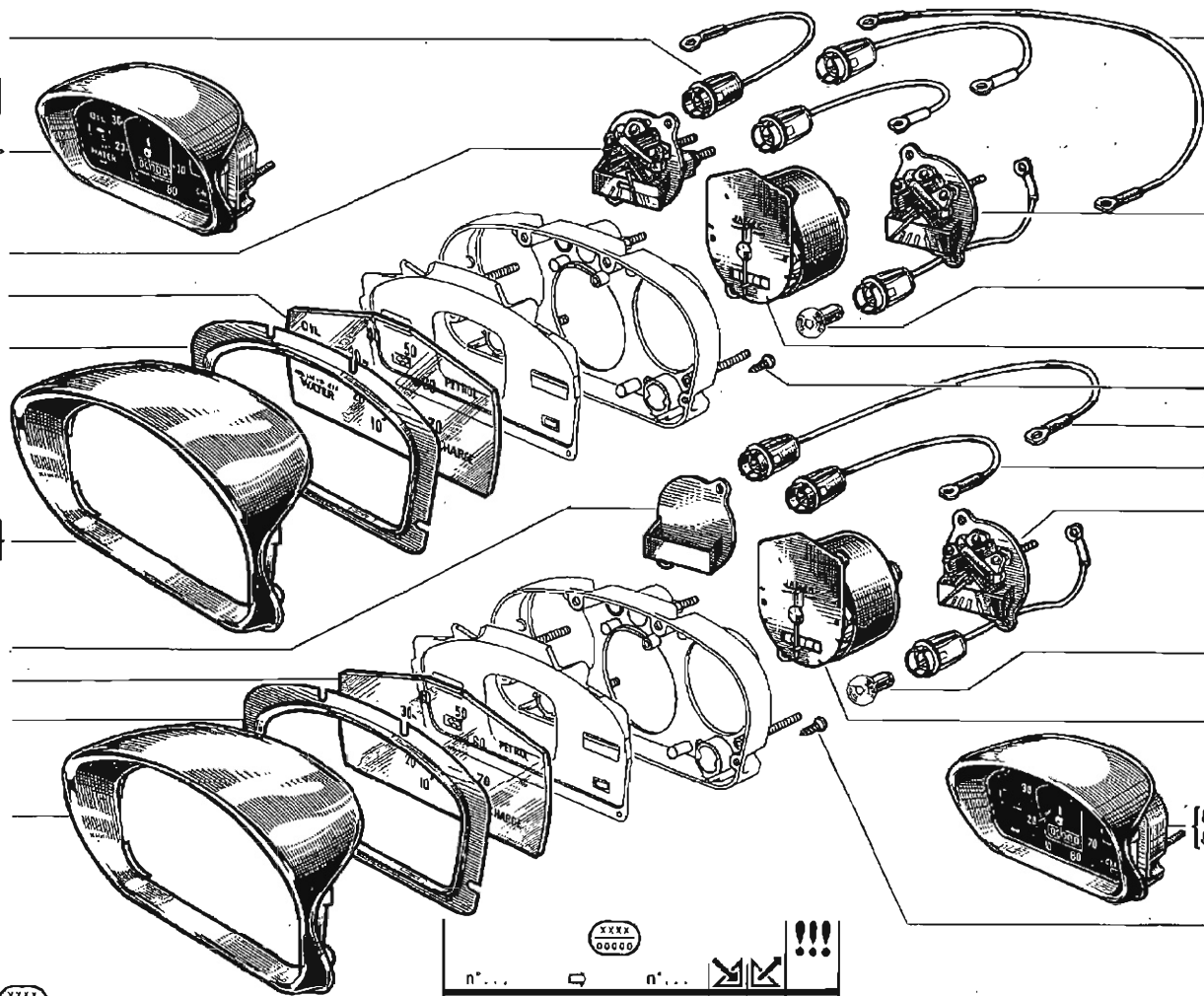

8 543 580 LO=17

(1)

8 506 238 DE=15
8 511 180 DE=11

8 537 323

8 537 612

8 537 608

8 537 320

8 544 813

8 542 589 LO=200

8 539 586 LO=125

8 537 316

8 537 321

8 537 611

8 506 238 DE=15
8 511 180 DE=11

8 541 872

8 537 610

8 537 608

8 537 320

8 537 611

8 541 443 (d)
8 536 470 (a) AFFAIRES

8 544 813

32 XXXX
0000 00-00

	n°...		n°...	⚡	⚡	!!!
(a)	532893 VEH		1-5-1958	32		
(b)	1-6-1958 VEH		856040			
(c)	856041 VEH		...			
(d)	1-6-1958 VEH		...			

	8546060	8541447 8543184 8541445	8537046 8536472
(1)	8546052	8541974	8537316

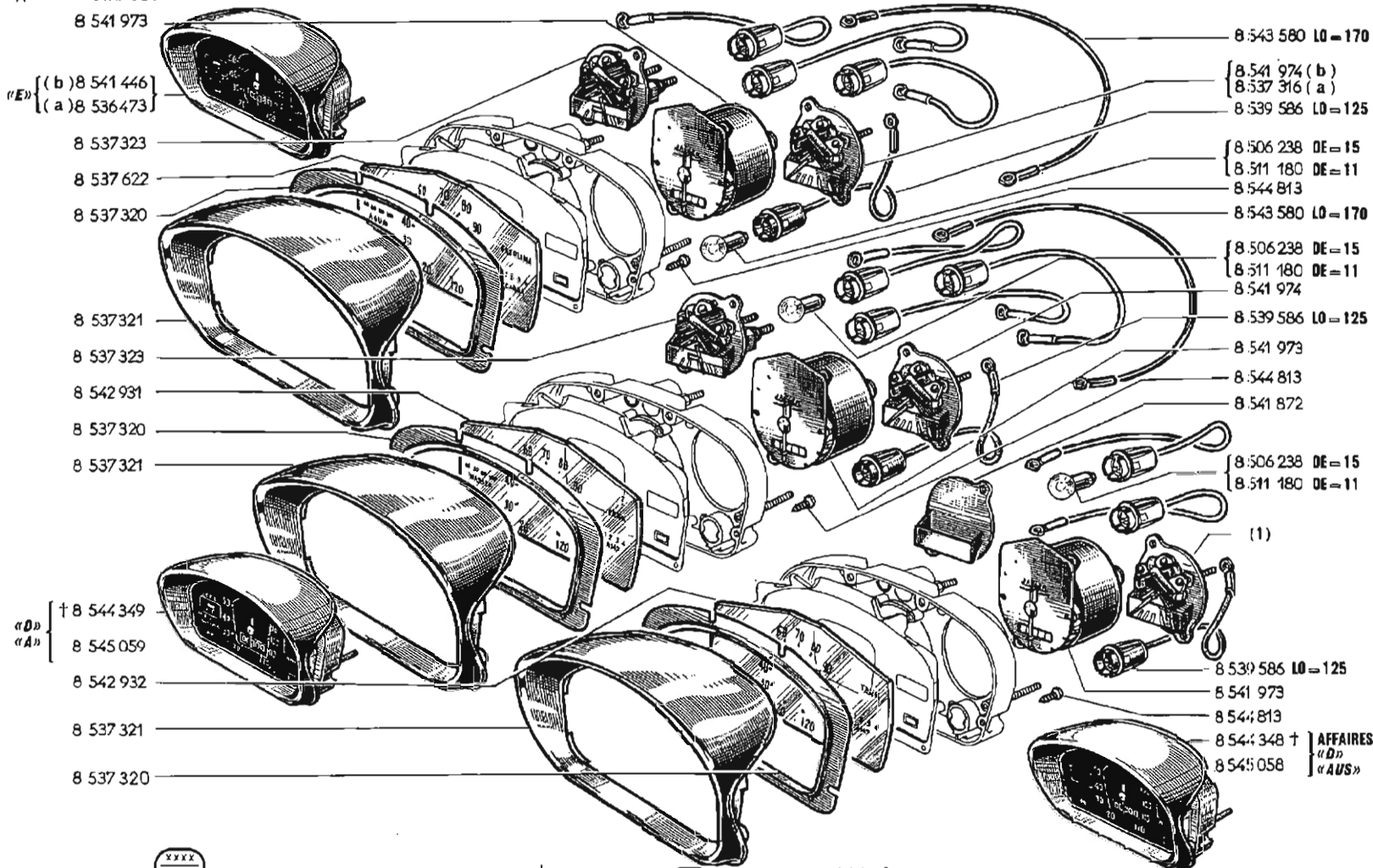

- 8 541 973
- «E» { (b) 8 541 446
- (a) 8 536 473 }
- 8 537 323
- 8 537 622
- 8 537 320
- 8 537 321
- 8 537 323
- 8 542 931
- 8 537 320
- 8 537 321
- «D» { † 8 544 349
- «A» { 8 545 059
- 8 542 932
- 8 537 321
- 8 537 320

- 8 543 580 LO = 170
- { 8 541 974 (b)
- 8 537 316 (a)
- 8 539 586 LO = 125
- { 8 506 238 DE = 15
- 8 511 180 DE = 11
- 8 544 813
- 8 543 580 LO = 170
- { 8 506 238 DE = 15
- 8 511 180 DE = 11
- 8 541 974
- 8 539 586 LO = 125
- 8 541 973
- 8 544 813
- 8 541 872
- { 8 506 238 DE = 15
- 8 511 180 DE = 11
- (1)
- 8 539 586 LO = 125
- 8 541 973
- 8 544 813
- 8 544 348 †
- 8 545 058

«AUS»

XXXX
00000

32

08-00



	n°...	⇨	n°...	MX	!!!
(a)	532893 VEH		1-5-1958	32	
(b)	1-6-1958 VEH		...		

8544349	8545059
8544348	8545058
(1) 8541974	8545047

A P.R. 685

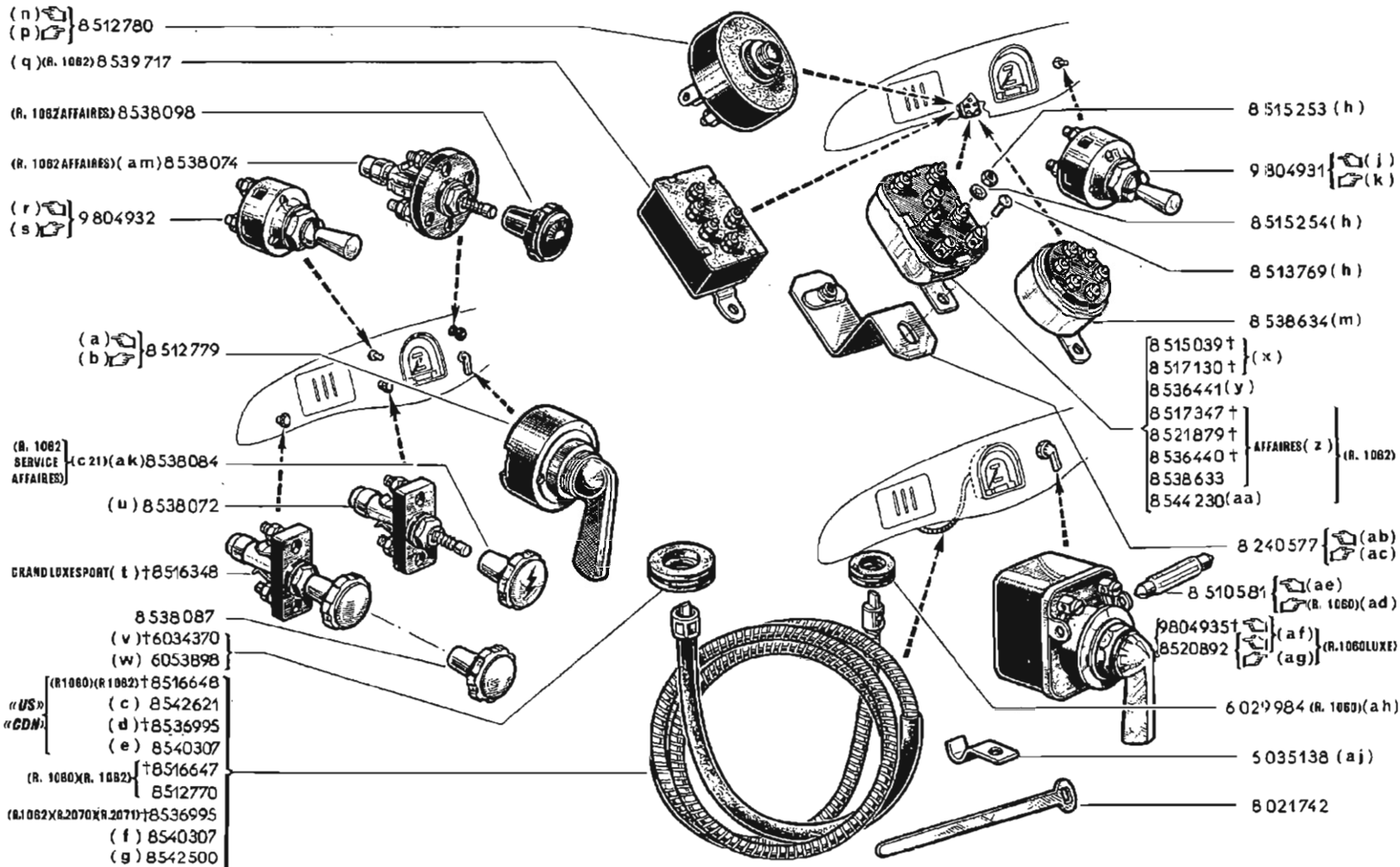
A P.R. 685



	n°... 	n°... 	
(a) R.1060 NORMAL	3835 VEH	74349	
R.1060 LUXE	3835 VEH	33703	
R.2070	448 VEH	8820	
(b) R.1060 NORMAL	34 VEH	74349	
R.1060 LUXE	34 VEH	3730	
(c) R.1060			
R.1062	1 VEH	532892	32
(d) R.1062	532893 VEH	...	32
(e) R.1062	532893 VEH	812763	32
(f) R.1062	1 VEH	812763	
(g) R.1062	812764 VEH	...	
(h) R.1060	64484 VEH	...	
R.1062			
R.2071			
R.2070	8013 VEH	...	
(j) R.1060	1 VEH	3834	
R.2070	1 VEH	447	
(k) R.1060	1 VEH	33	
(m) R.1062 AFFAIRES			
R.2070	8013 VEH	...	
R.2071			
R.1060	64484 VEH	...	
(n) R.1080	3835 VEH	64483	
R.2070	448 VEH	8012	
(p) R.1080	34 VEH	64483	
(q)			
"US"	1 VEH	...	
"D"	840300 VEH	880289	
"A"	880290 VEH	...	
"CH"	880290 VEH	...	
"CH"	894652 VEH	...	
(r) R.1060 NORMAL	3835 VEH	74349	
R.1060 LUXE	3835 VEH	64483	
R.2070	448 VEH	8820	
(s) R.1060 NORMAL	34 VEH	74349	
R.1060 LUXE	34 VEH	64483	
(t) R.1060			
R.1062	1 VEH	405209	
	405601 VEH	406426	



32



	n°...	n°...	!!!
(u) R.1060 NORMAL			
R.1062 NORMAL			
R.1060 LUXE	1 VEH	7816	
R.2070			
R.2071			
R.1062 SERVICE	405210 VEH	405600	
R.1062 AFFAIRES	406427 VEH	532892	32
(v) R.1060	101 VEH	400	
(w) R.1060	101 VEH	400	
R.1062			
R.2070			
R.2071			
(x) R.1060	64484 VEH	...	
(y) R.1060	64484 VEH	...	
R.1062 «US»	1 VEH	840299	
R.1062 AFFAIRES	1 VEH	299119	
R.2070	8013 VEH	...	
R.2071	8013 VEH	...	
(z)	299120 VEH	...	
(aa) «DK»	1-11-1959 VEH	...	
(ab) R.1060	64484 VEH	123258	
R.2070	8013 VEH	10610	
(ac) R.2070	8013 VEH	75	
(ad)	34 VEH	...	
(ae) R.1060	3835 VEH	...	
R.1062 «GH»	1 VEH	894651	
R.1062	894652 VEH	...	
R.2071	448 VEH	...	
R.2070			
(af)	33704 VEH	64483	
(ag)	3731 VEH	64483	
(ah)	1 VEH	100	
(aj) R.1060	1501 VEH	...	
R.1062			
R.2071			
R.2070	121 VEH	...	
(ak)	405210 VEH	405600	
	406427 VEH	532892	32
(am)	1 VEH	405209	
	405801 VEH	406426	



XXXX
06000

32 08-00

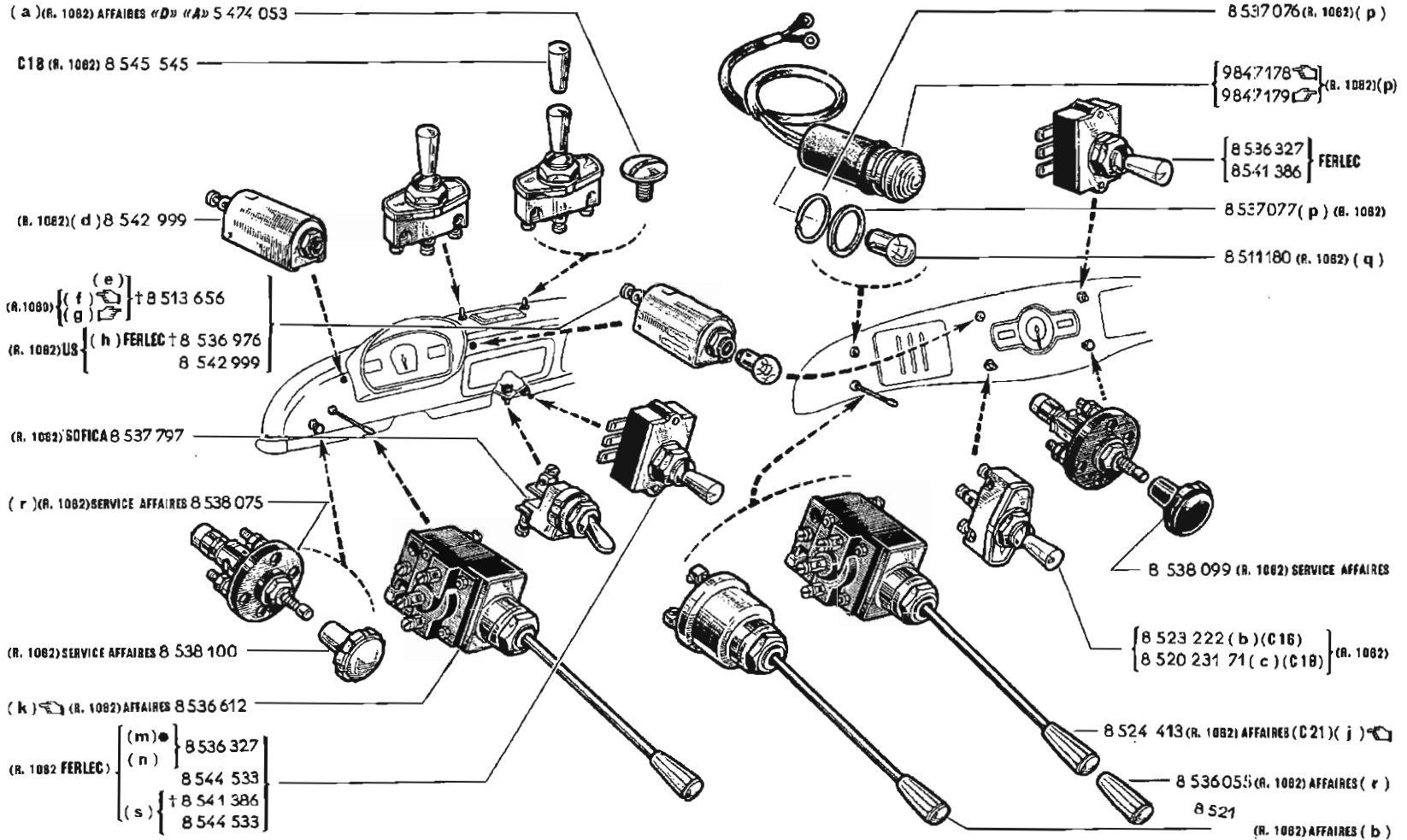



	n°...	n°...	!!!
(a)	840861 VEH	...	
(b) AFFAIRES	1 VEH	405209	
	405601 VEH	406426	
(c) AFFAIRES	405210 VEH	405600	
AFFAIRES	406427 VEH	...	
«DK»	1-11-1959 VEH	...	
(d) «D»	840861 VEH	...	
«A»	840861 VEH	...	
«CH»	869016 VEH	894651	
«CDN» «US»	894652 VEH	...	
(e) R.1062 FERLEC			
R.1060 LUXE			
R.1060 «CDN» «US»			
R.1062 LUXE			
R.1062 «CDN» «US»			
R.2070	5564 VEH	8825	
(f)	40967 VEH	61870	
(g)	3835 VEH	61870	
(h)			212
(j)	405210 VEH	405600	32
	406427 VEH	532892	32
(k)	532893 VEH	...	32
(m)	1 VEH	841460	
(n)	1 VEH	784407	
(p)	504214 VEH	532892	32
(q) FERLEC			212
«D»	840861 VEH	...	
«A»	840861 VEH	...	
«CH»	869016 VEH	894651	
(r)	405210 VEH	405600	
	406427 VEH	...	
(s)	784408 VEH	841460	

32  

212  



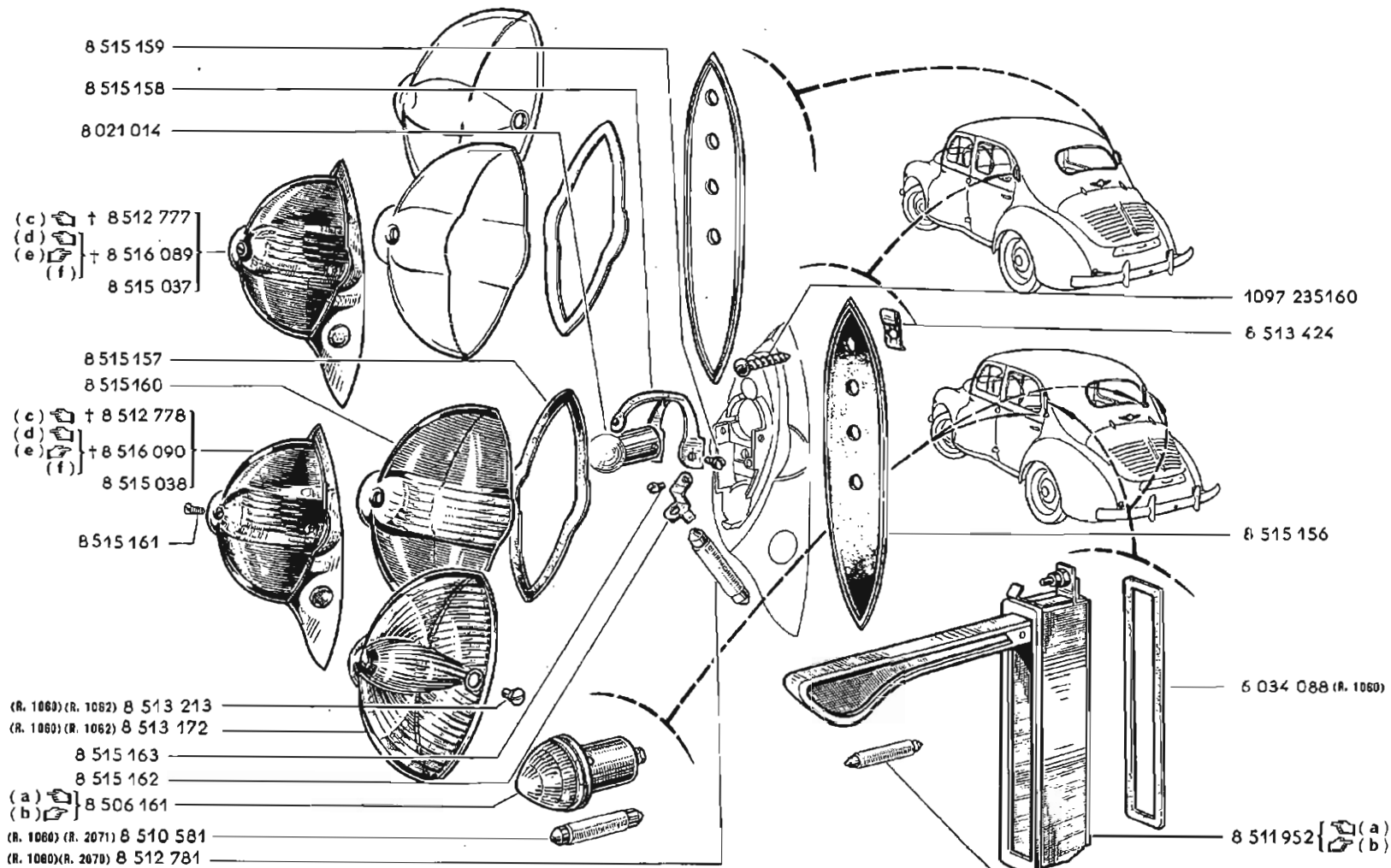

- (a) { R 1060 CAR n° 1 ⇨ CAR n° 3834
R 2070 CAR n° 1 ⇨ CAR n° 447
- (b) R 1060 CAR n° 1 ⇨ CAR n° 33
- (c) { R 1060 CAR n° 3835 ⇨ CAR n° ...
R 1062

- (d) R 1060 CAR n° 3835 ⇨ CAR n° ...
- (e) R 1060 CAR n° 34 ⇨ CAR n° ...
- (f) { R 1062 VEH n° 1 ⇨ VEH n° 59914
R 2070 CAR n° 448 ⇨ CAR n° ...
R 2071 VEH n° 1 ⇨ VEH n° 2270

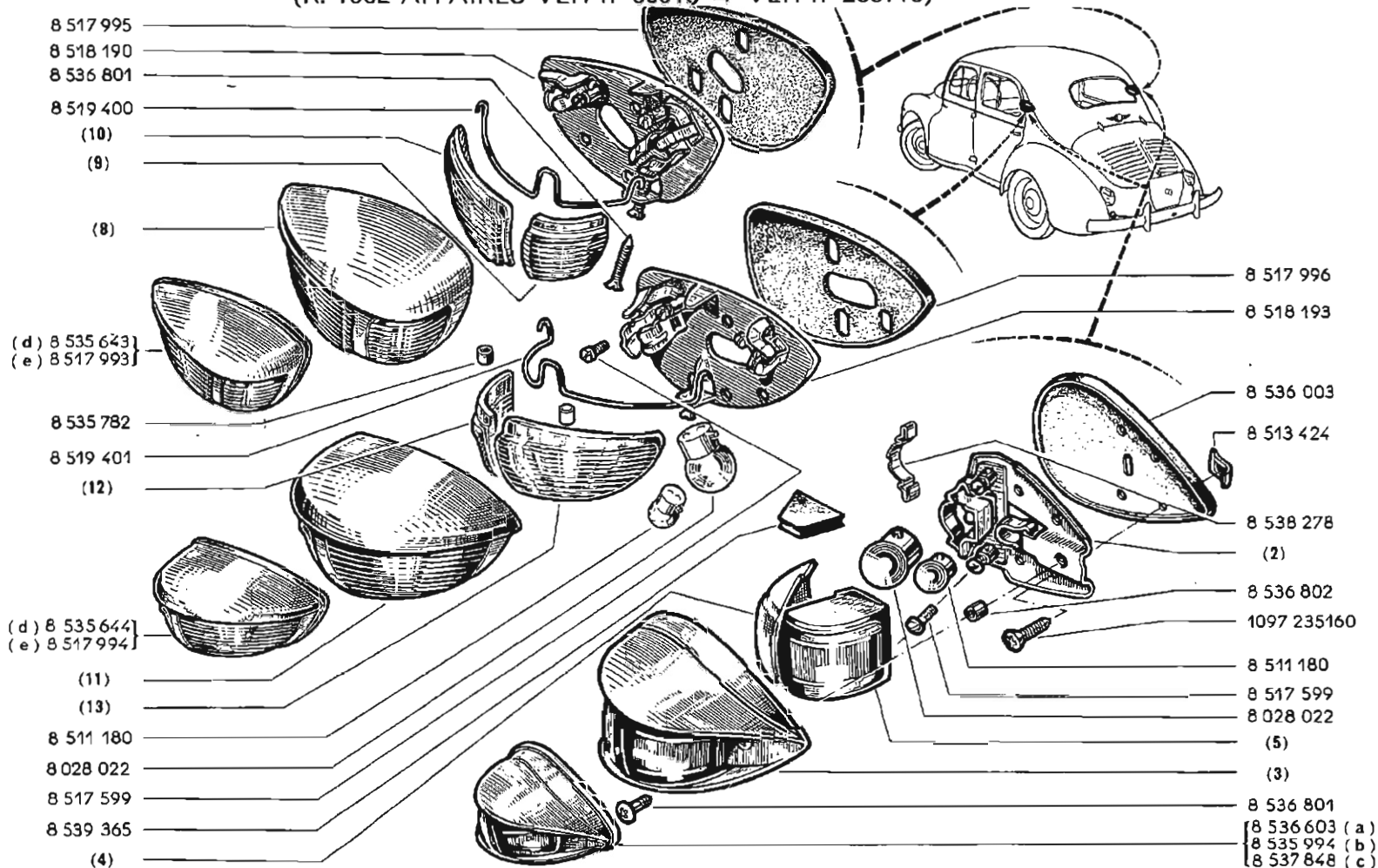

	8537848	8536603	8535994
(2)	8536794	8536803	8536794
(3)	8536805	8536805	8536795
(4)	8536808	8536808	8536797
(5)	8536809	8536809	8536799

	8535643	8517993
(8)	8519392	8518195
(9)	8519396	8518923
(10)	8519398	8518925

	8535644	8517994
(11)	8519393	8518194
(12)	8519397	8518924
(13)	8519399	8518926

(a) R 1062 «B» VEH n° 486556 ⇨ VEH n° 1-4-1957
 (b) R 1062 «S» VEH n° 473556 ⇨ VEH n° 602244
 (c) R 1062 «S» VEH n° 602245 ⇨ VEH n° 1-4-1957

(d) { R 1062 «B» VEH n° 1 ⇨ VEH n° 486555
 R 2071 «B» VEH n° 1 ⇨ VEH n° 486555
 (e) { R 1062 SPORT VEH n° 59915 ⇨ VEH n° 473555
 R 1062 AFFAIRES VEH n° 59915 ⇨ VEH n° 283715
 R 2071 VEH n° 2271 ⇨ VEH n° ...

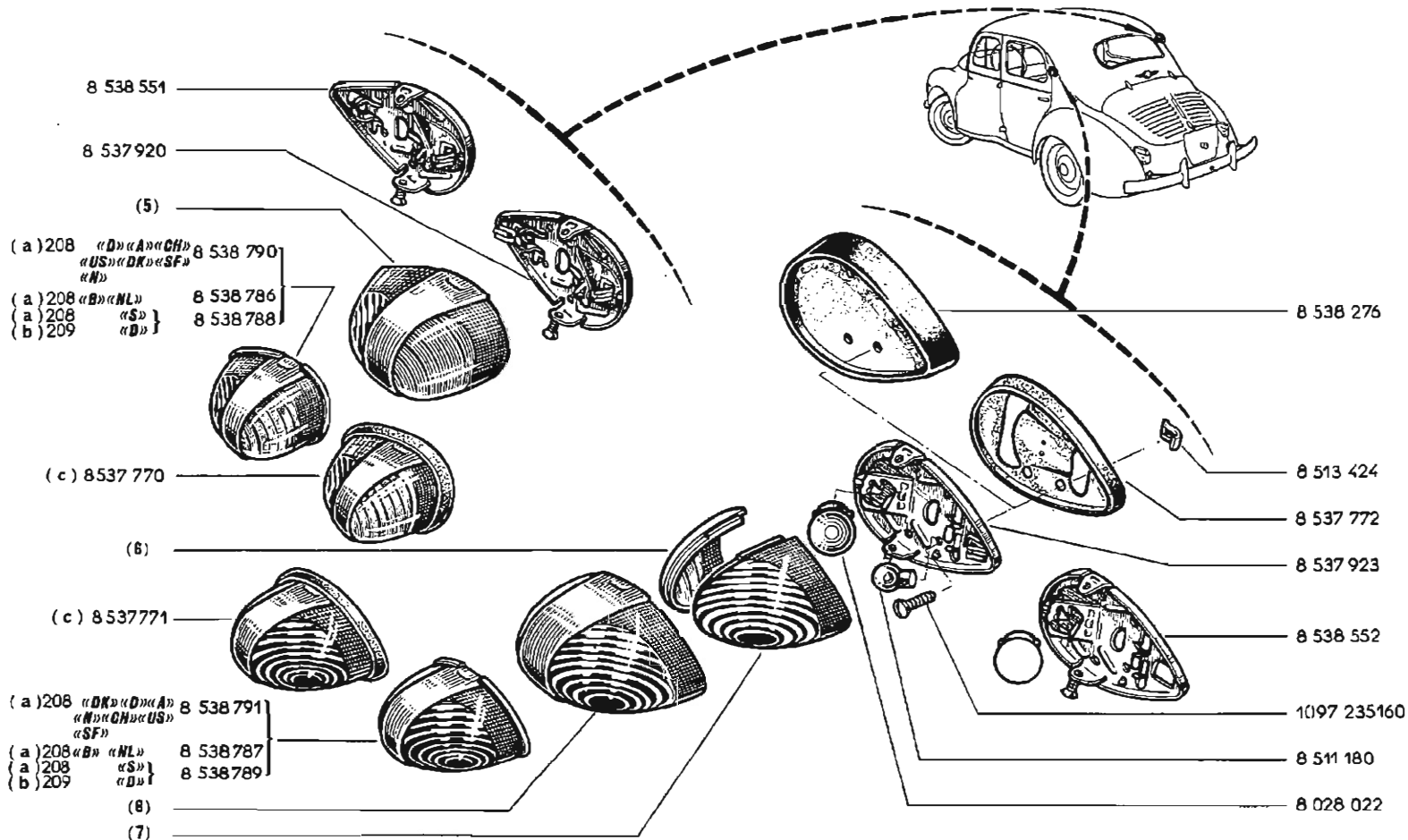

	8538788	8538786	8538790		8537770		8538789	8538787	8538791
(5)	8538555	8538555	8538553	(5)	8537922	(8)	8538556	8538556	8538554
(6)	8538609	8538609	8538608	(6)	8538606				
(7)	8538610	8538610	8538607	(7)	8538607				

(a) VEH n° 1-2-1956 ⇨ VEH n° 1-4-1957
 (b) VEH n° 1-2-1956 ⇨ VEH n° 1-4-1957
 (c) VEH n° 584748 ⇨ VEH n° 1-4-1957

208	08-00
209	08-00

PRELYO (R. 1062 «F»-«SF»-«N»-«S» 1-5-1957 ⇨ VEH n° 840860)
 (R. 1062 «A»-«D» 1-5-1957 ⇨ VEH n° 880289)
 (R. 1062 «DK»-«B»-«NL» 1-5-1957 ⇨ VEH n° ...)
 (R. 1062 «US» 1-5-1957 ⇨ VEH n° 840299)
 (R. 1062 «CH» VEH n° 1 ⇨ VEH n° 894651) (R.1062 «AUS»)

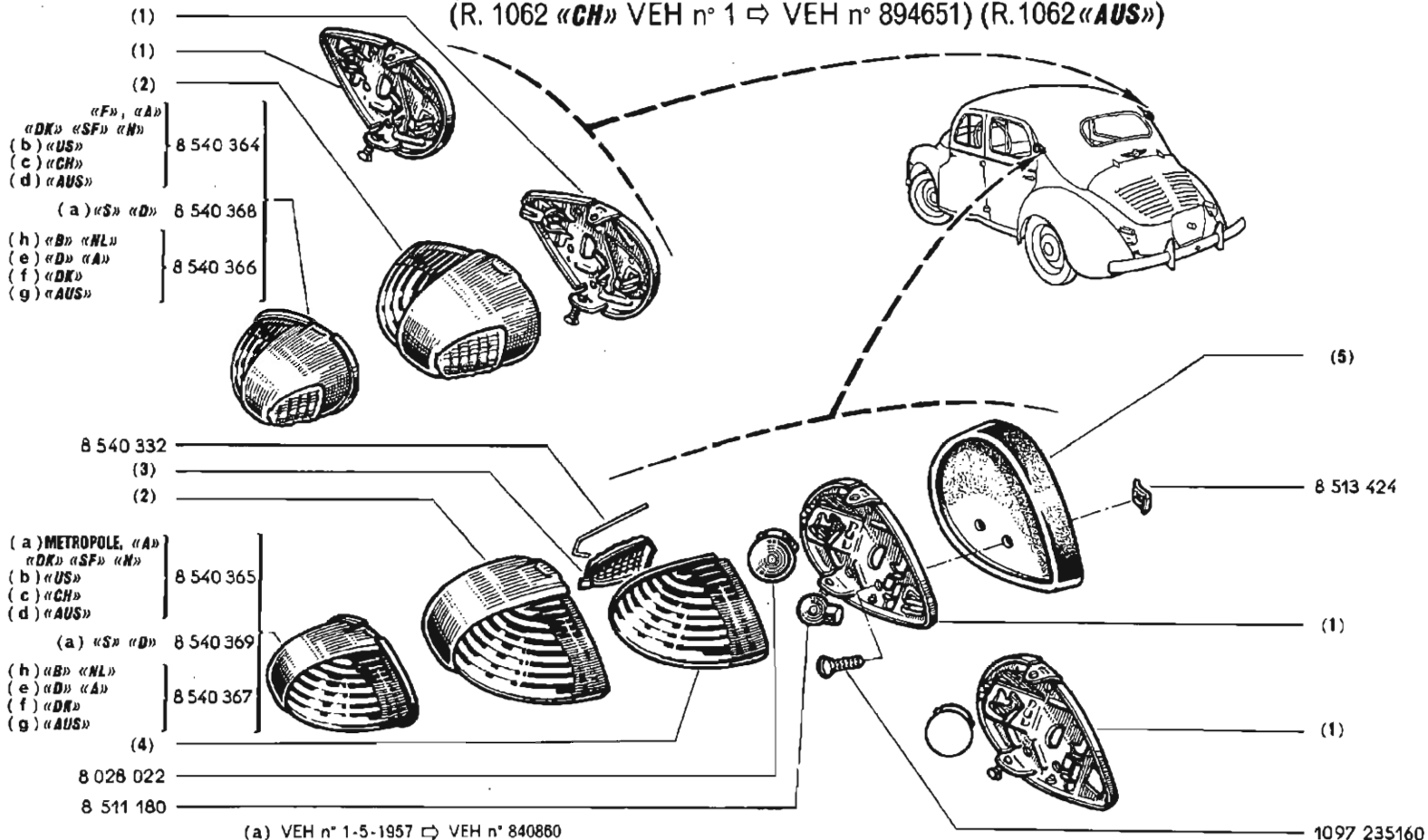

- (a) VEH n° 1-5-1957 ⇨ VEH n° 840860
- (b) VEH n° 1-5-1957 ⇨ VEH n° 840299
- (c) VEH n° 1 ⇨ VEH n° 894651
- (d) VEH n° 1 ⇨ VEH n° 836973
- (e) { SPORT VEH n° 840861 ⇨ VEH n° 880289
 AFFAIRES VEH n° 840861 ⇨ VEH n° ...
- (f) VEH n° 1-11-1959 ⇨ VEH n° ...
- (g) VEH n° 836974 ⇨ VEH n° ...
- (h) VEH n° 1-5-1957 ⇨ VEH n° ...

	8540364	8540365	8540366	8540367	8540368	8540369
(1)	8540316	8540317	8540318	8540319	8540316	8540317
(2)	8540324	8540325	8540326	8540327	8540326	8540327
(3)	8540330	8540330	8540331	8540331	8540331	8540331
(4)	8540333	8540333	8540334	8540334	8540334	8540334
(5)	8538276	8540356	8538276	8540356	8538276	8540356

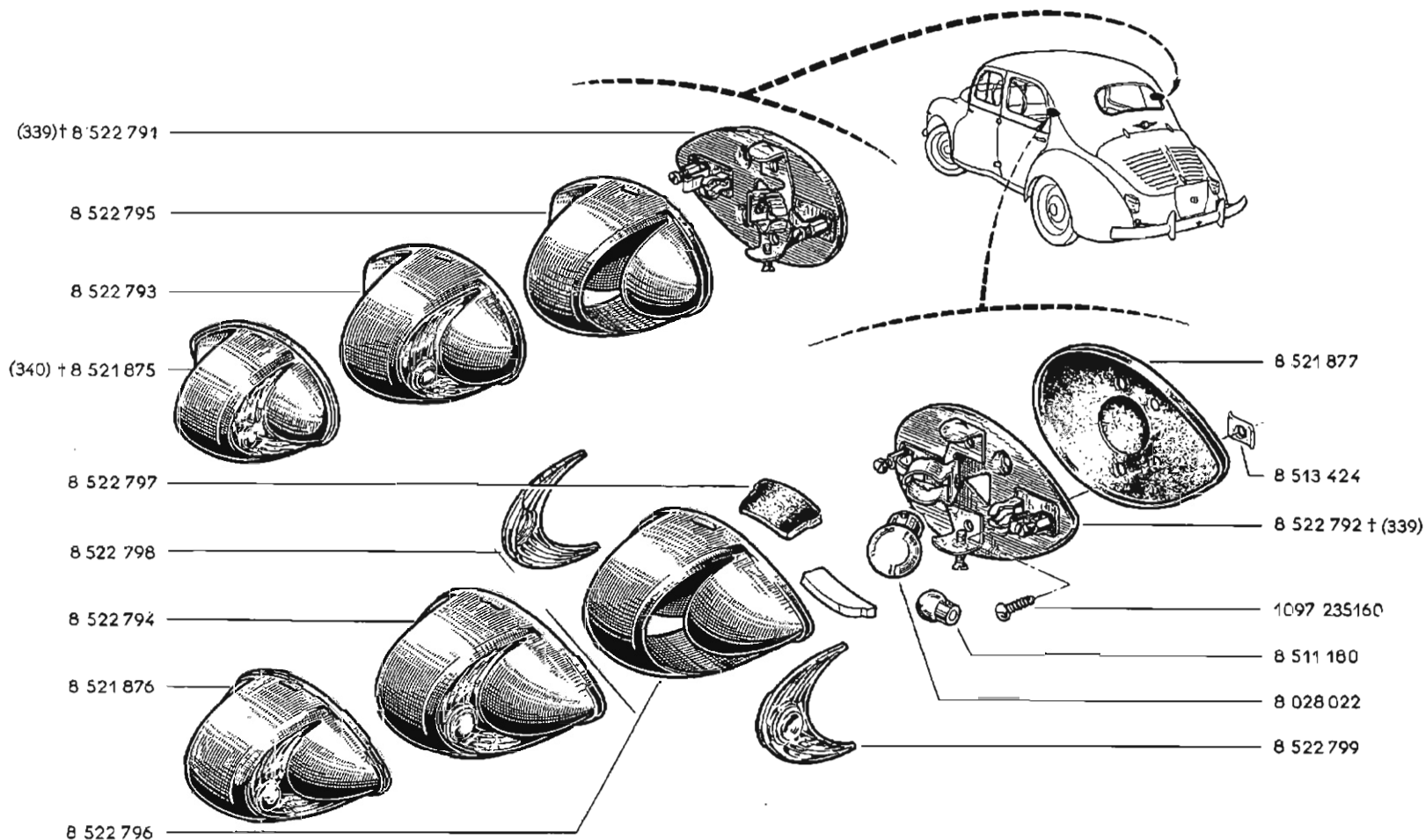

339	†	8540364 - 1 - } 8540365 - 1 - }	⊗ 62-28
340	†	8540364	⊗ 62-28

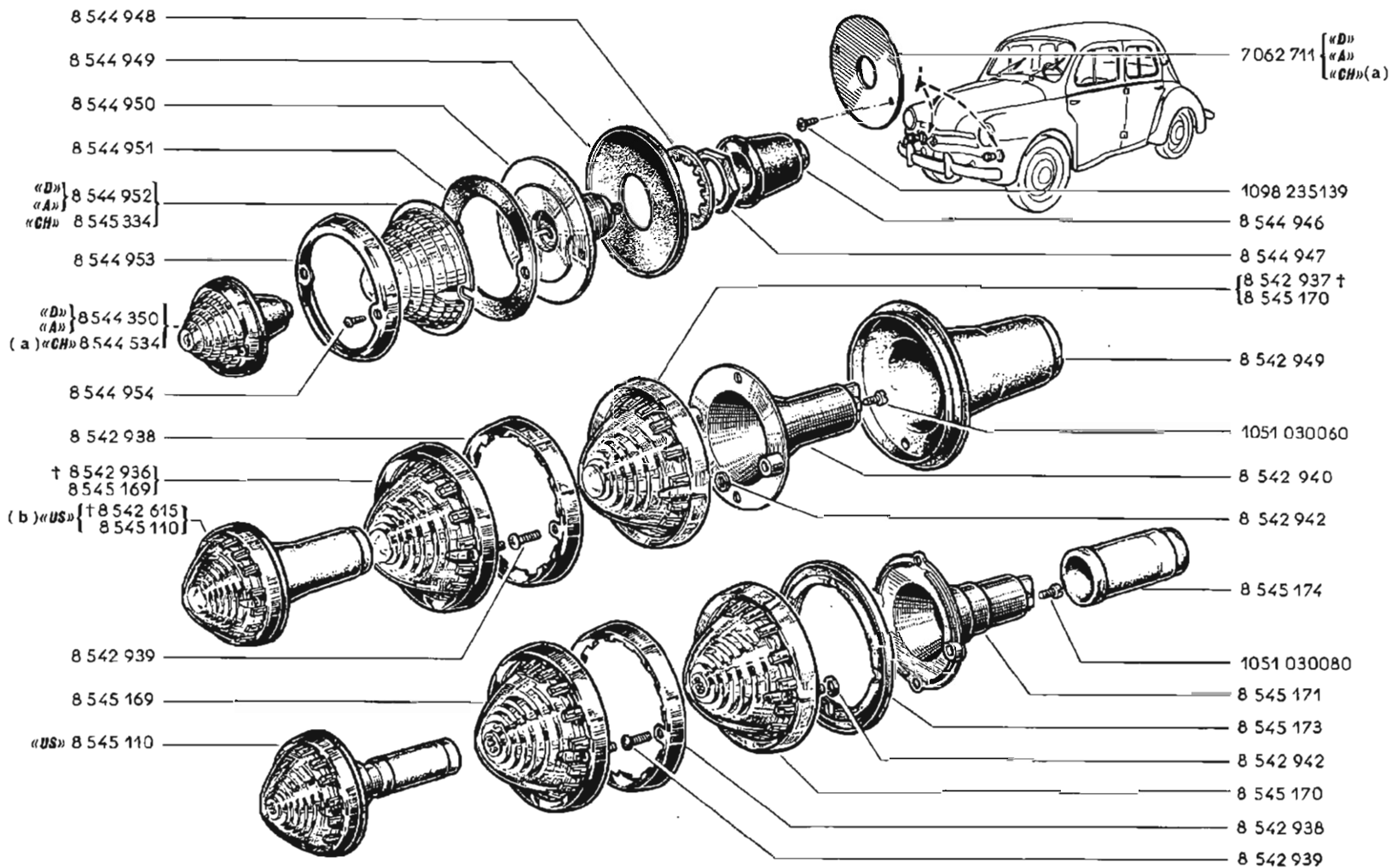

(a) VEH n° 894652 ⇔ VEH n° ...

(b) VEH n° 840300 ⇔ VEH n° ...

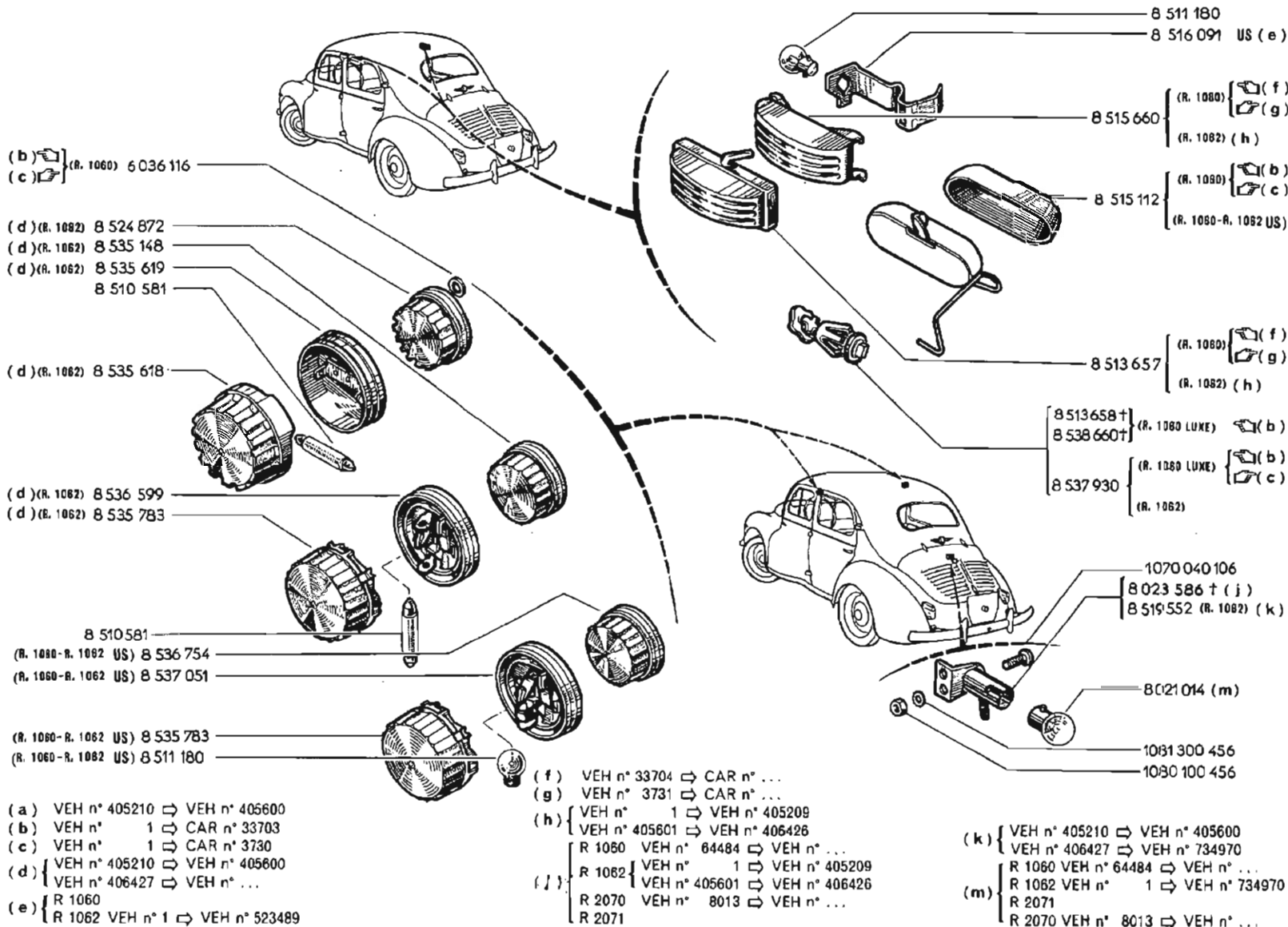

62.35

A P.R. 685

SEV

62.35

A P.R. 685

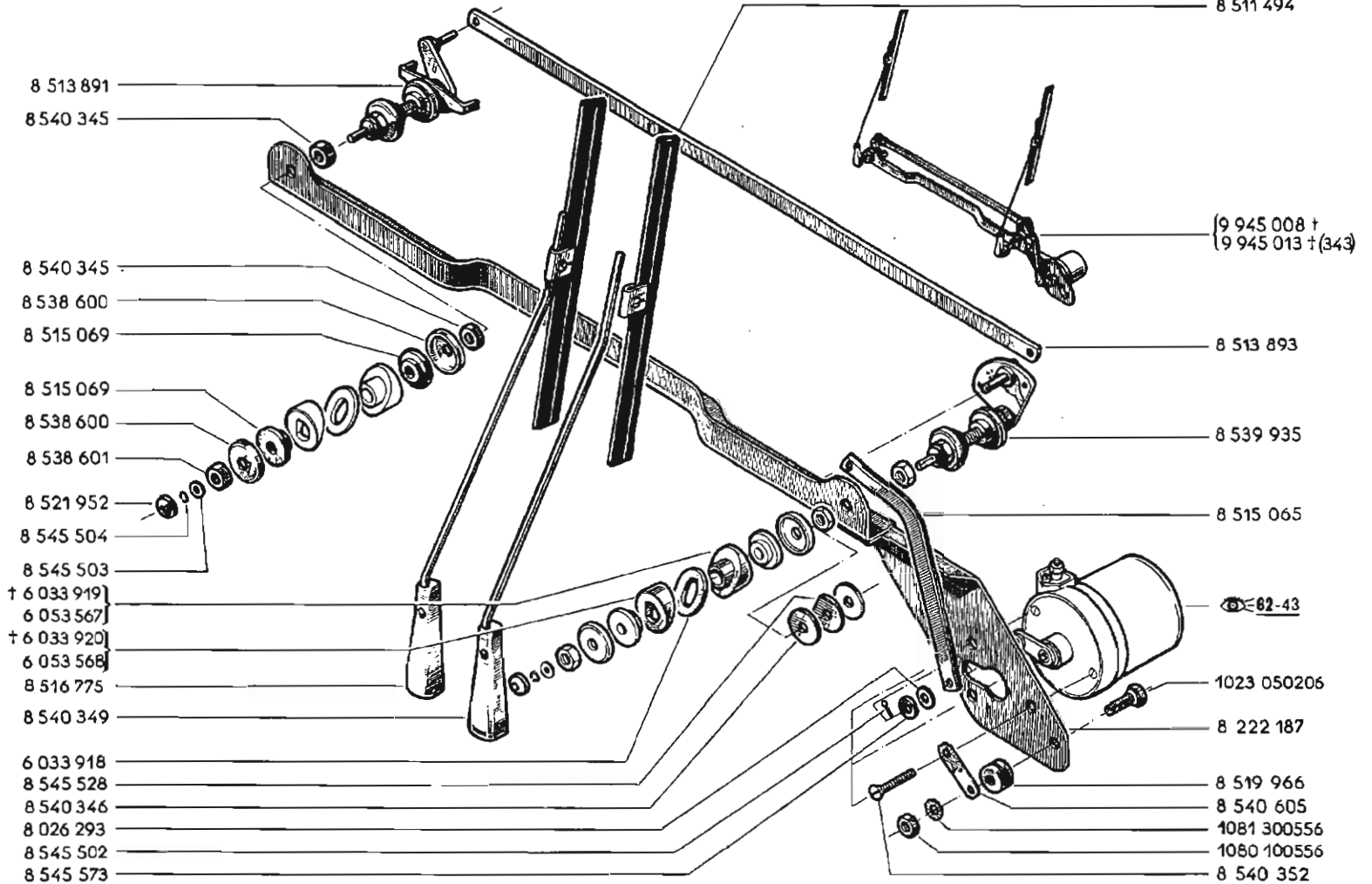

343	+	9945017	82-36
-----	---	---------	-------

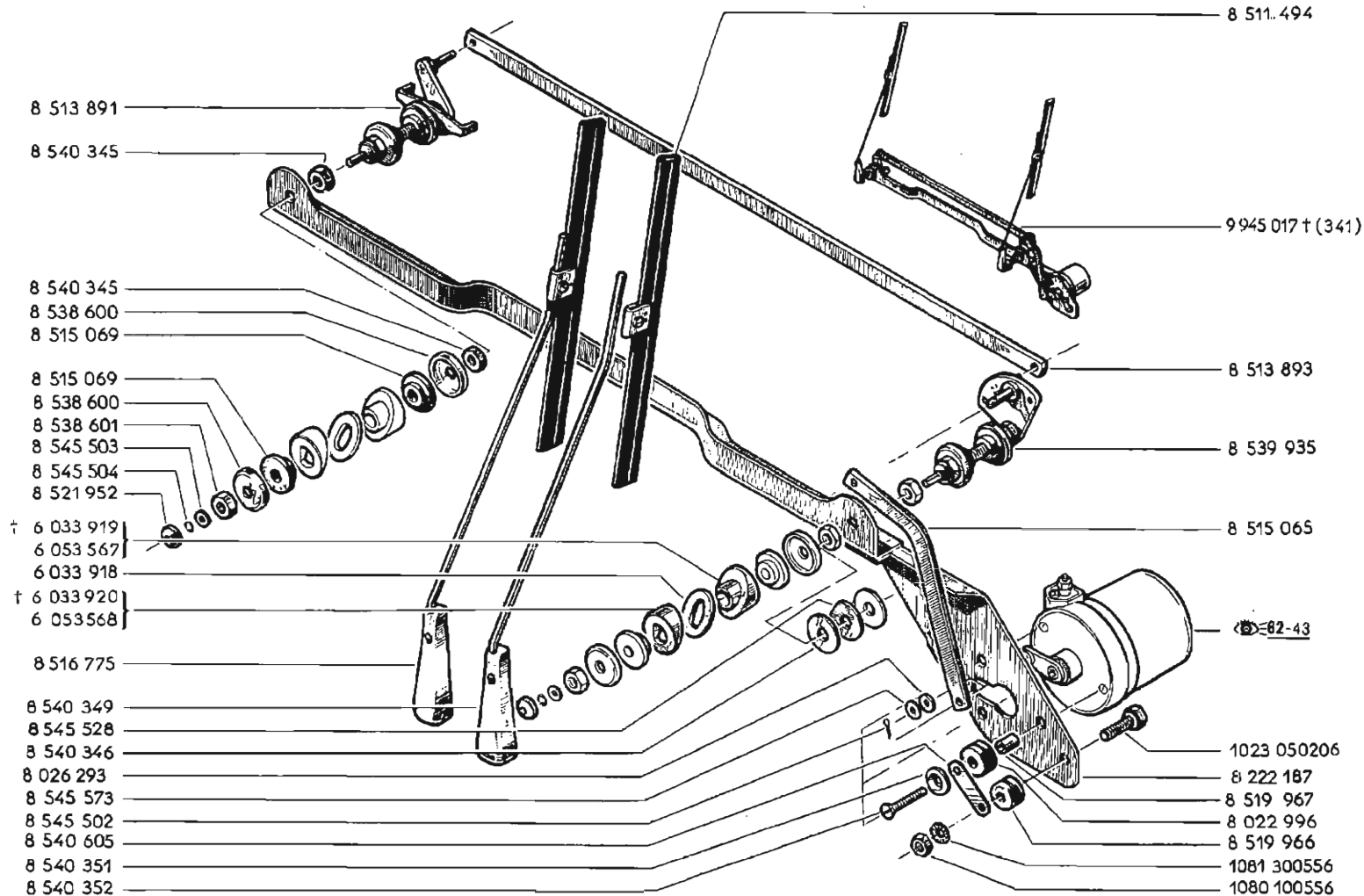

341

†

9945061

82-37

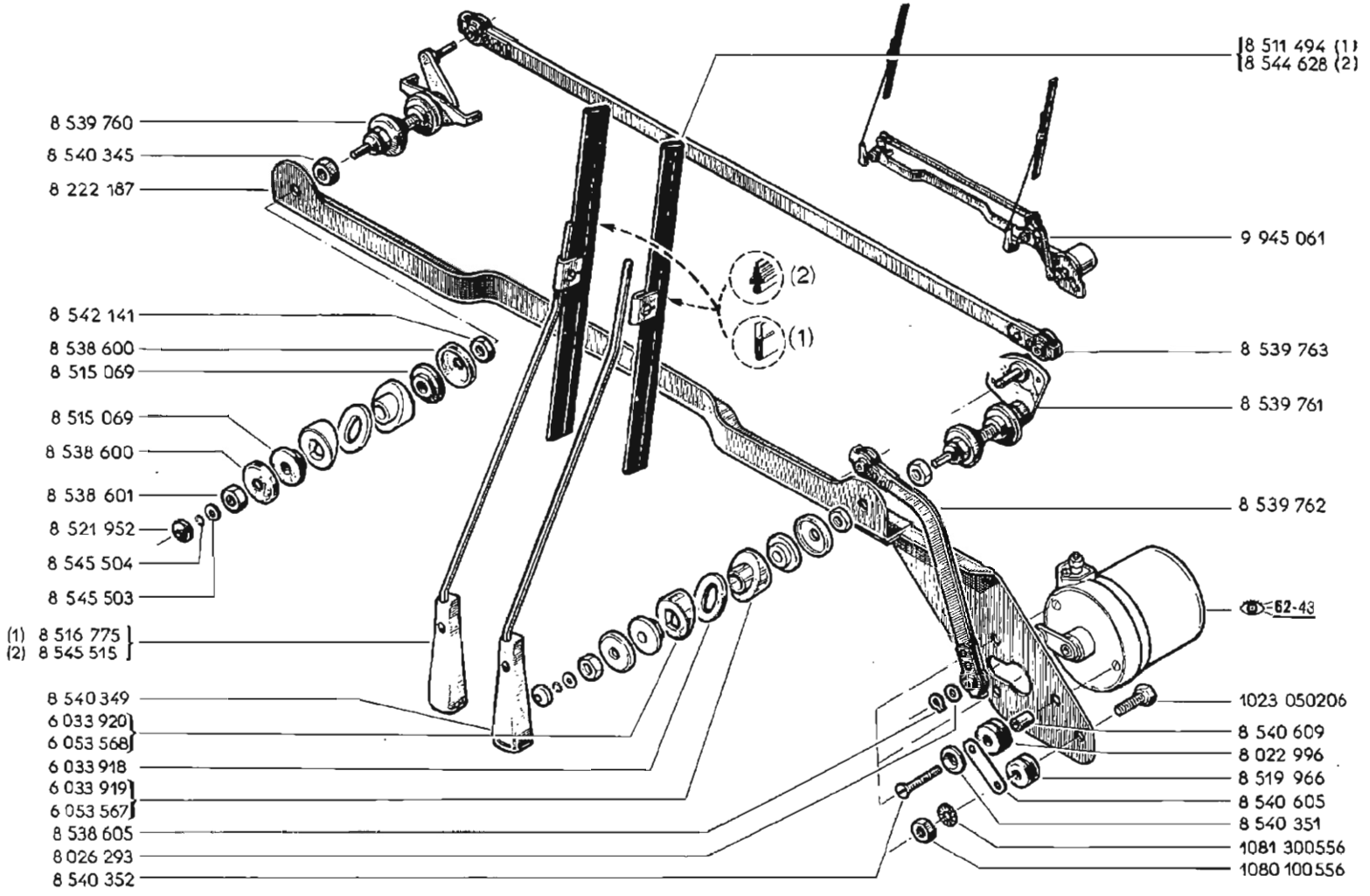

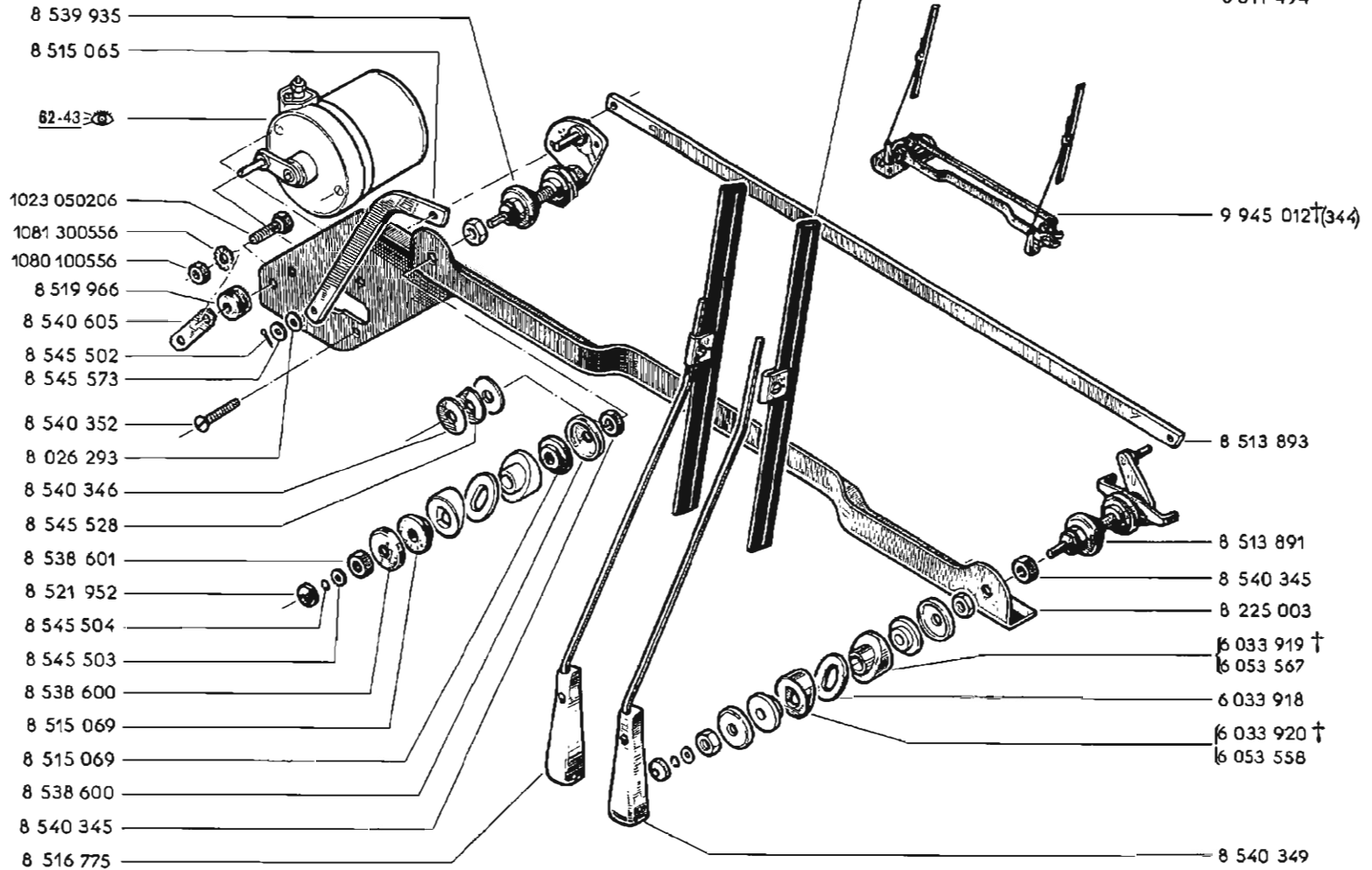

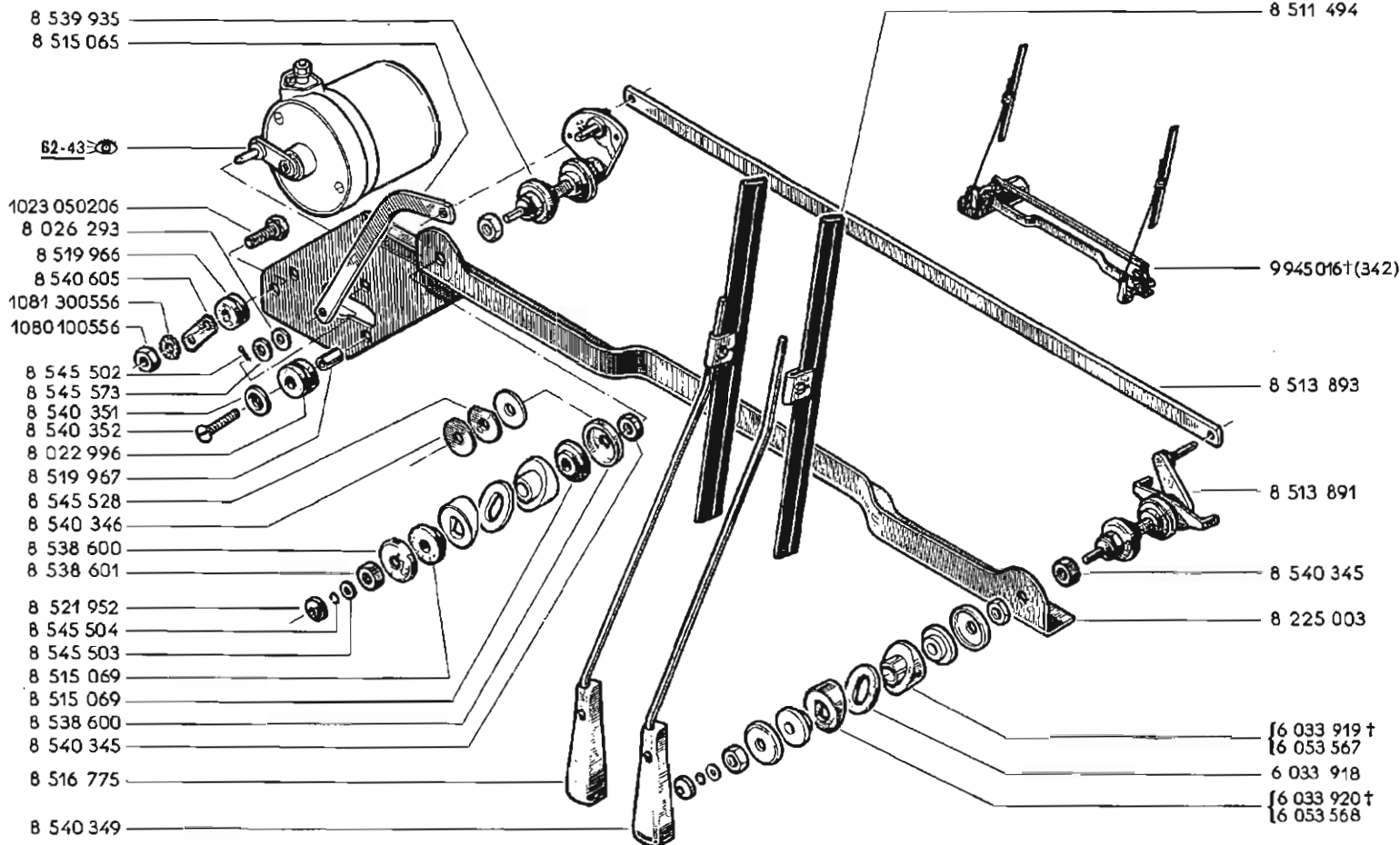

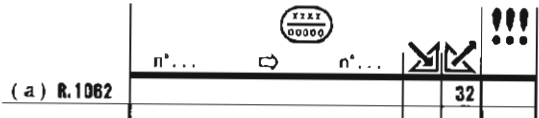
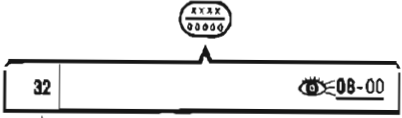
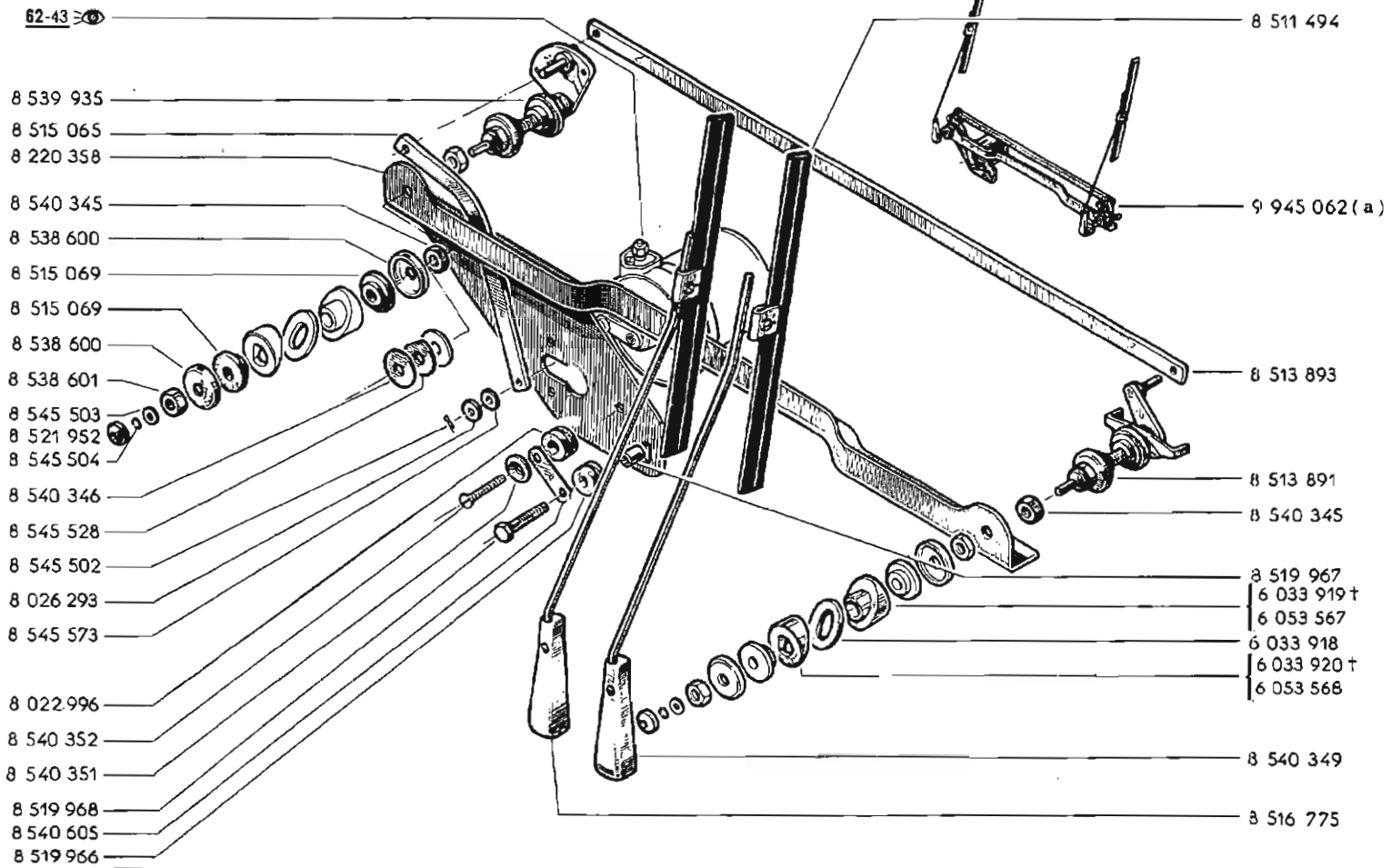

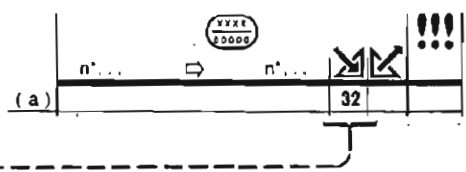
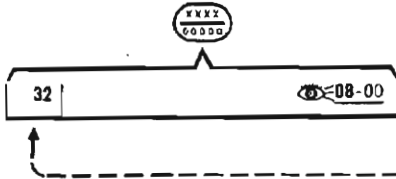
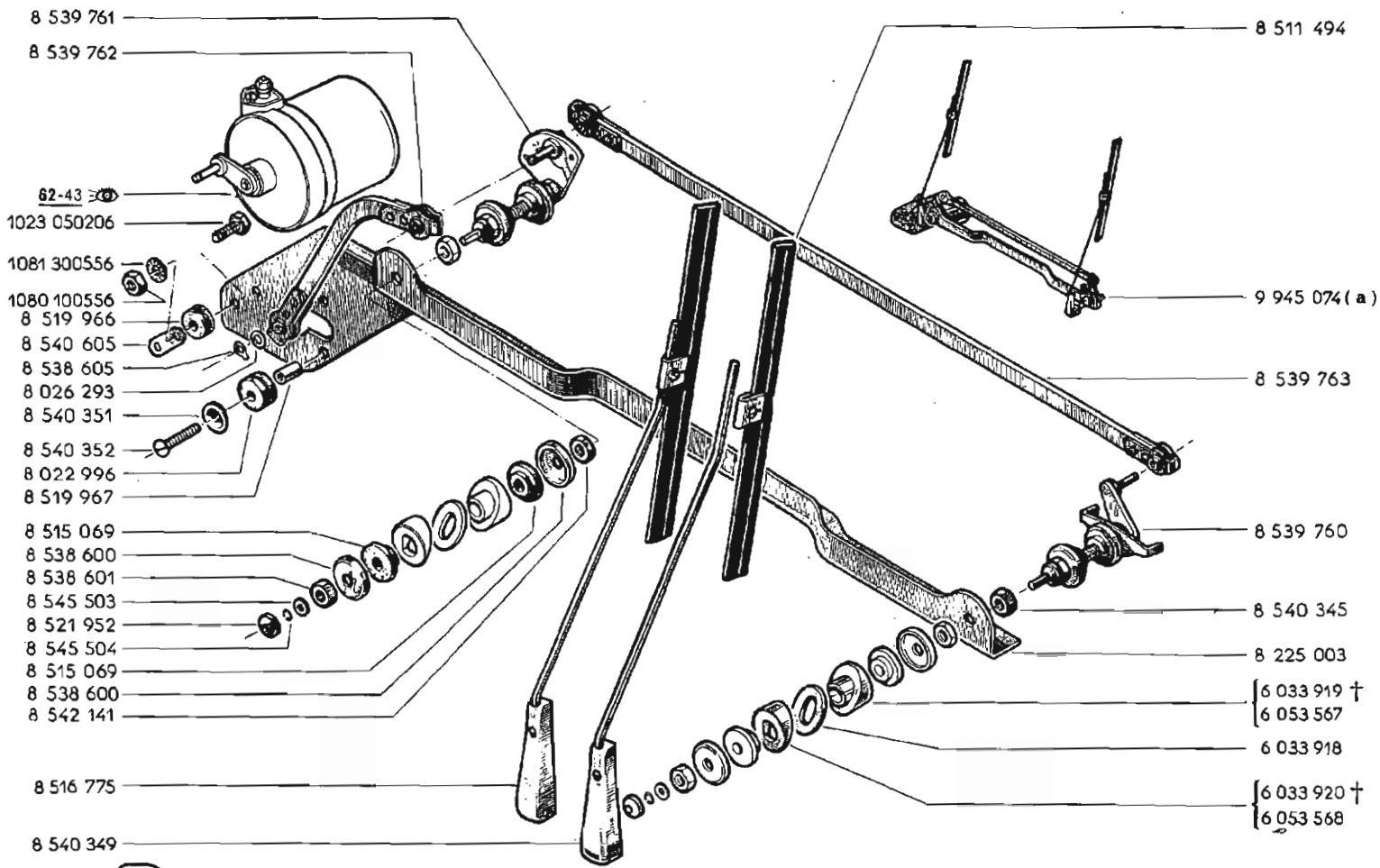

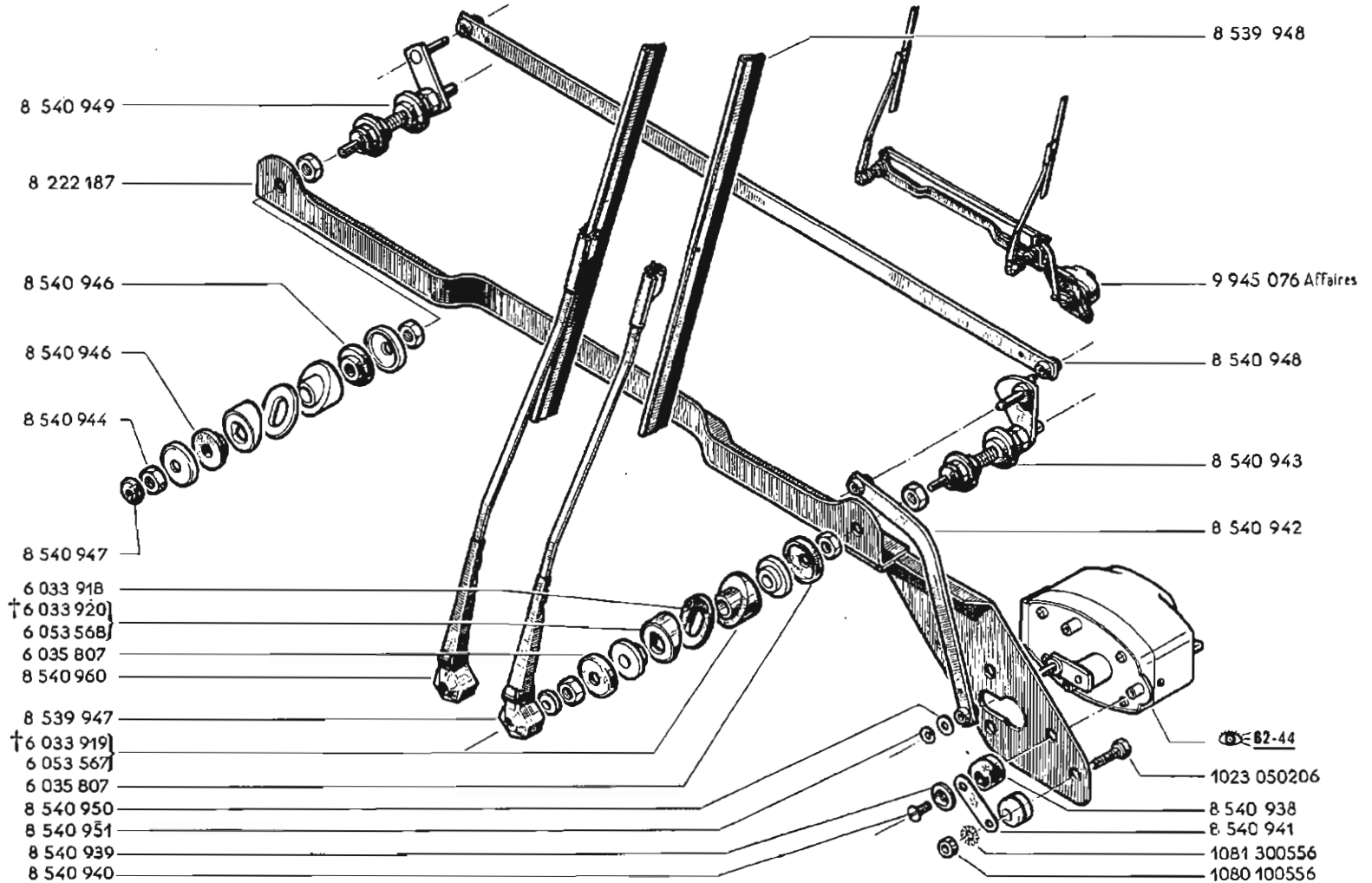

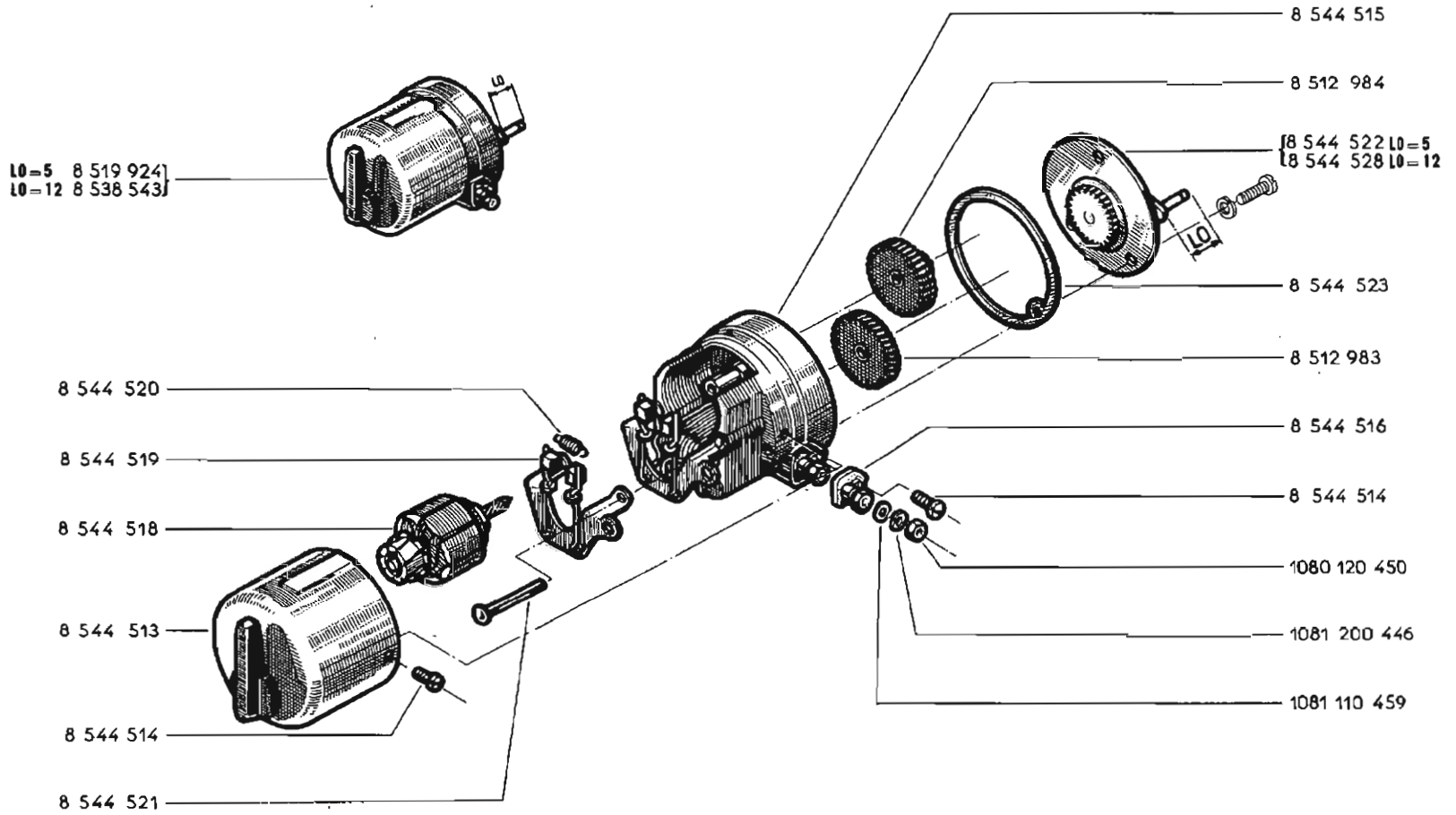

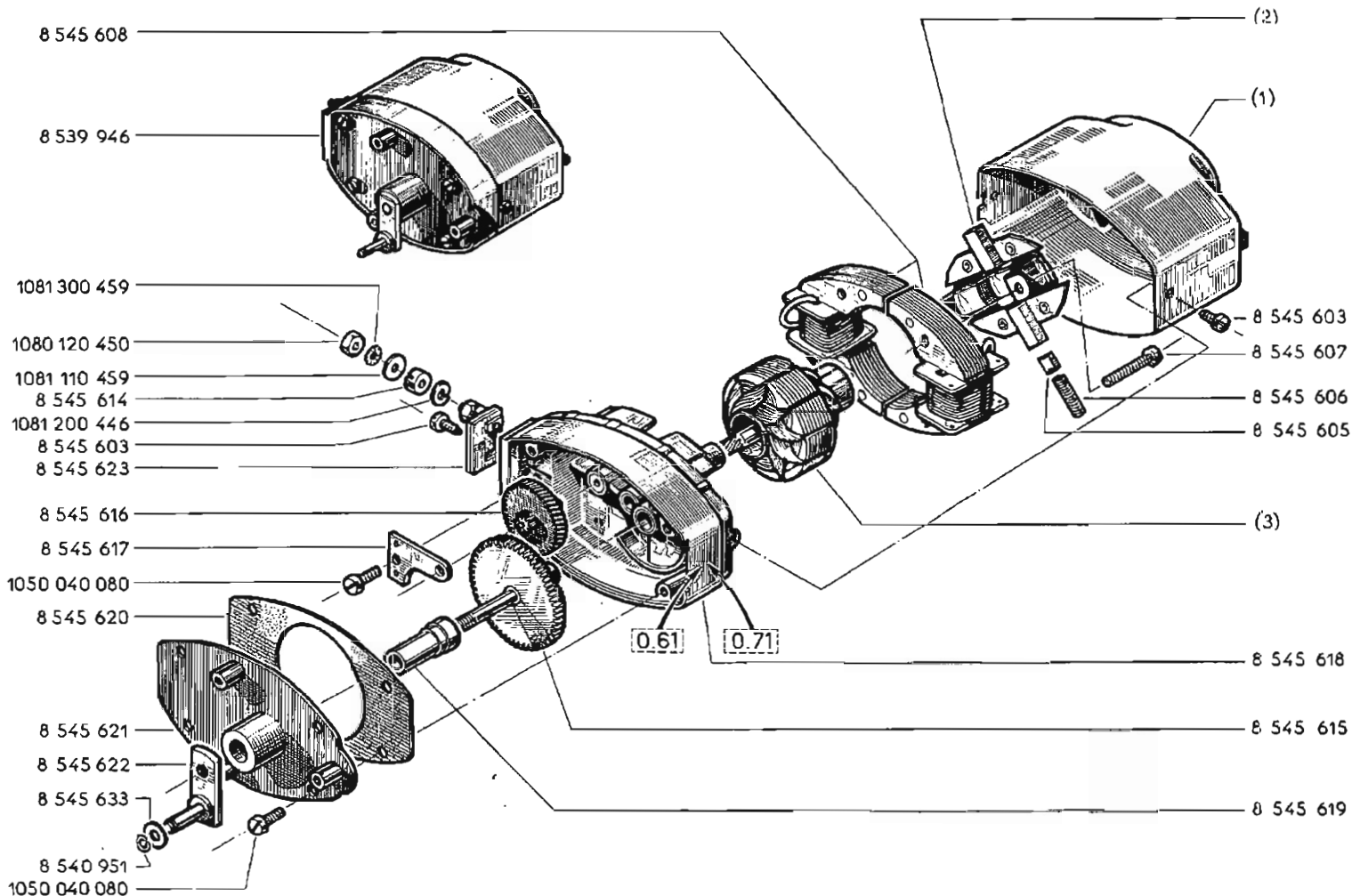

	0.61	0.71
(1)	8545705	8545602
(2)	8545632	8545604
(3)	8545631	8545609

- 1080 100 849
- 8 537 444
- 1081 300 859
- 1080 100 852

8 537 790

8 537 792

8 541 970

8 537 791

8 538 317

8 537 795

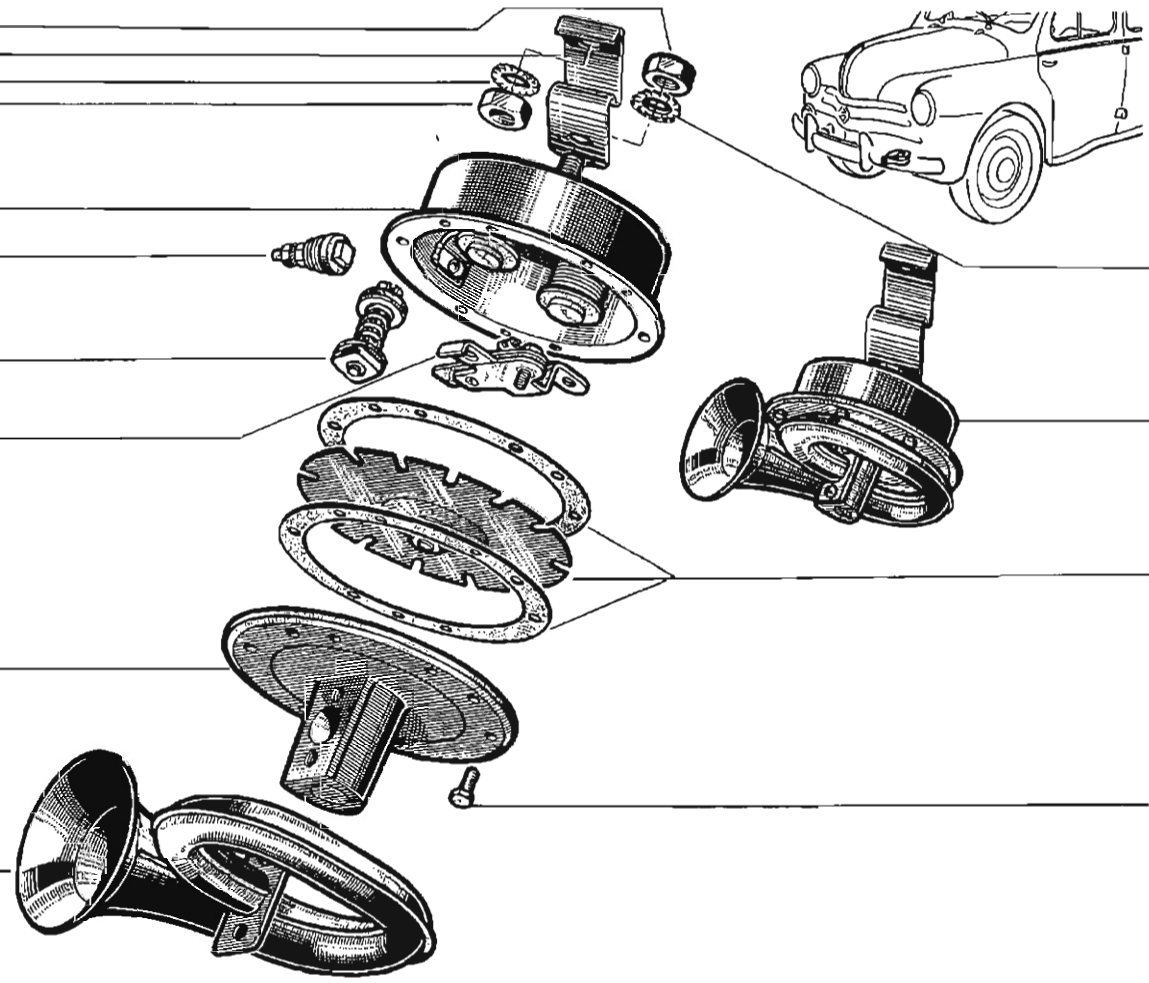

1081 300 859

8 537 660

8 537 794

8 540 274

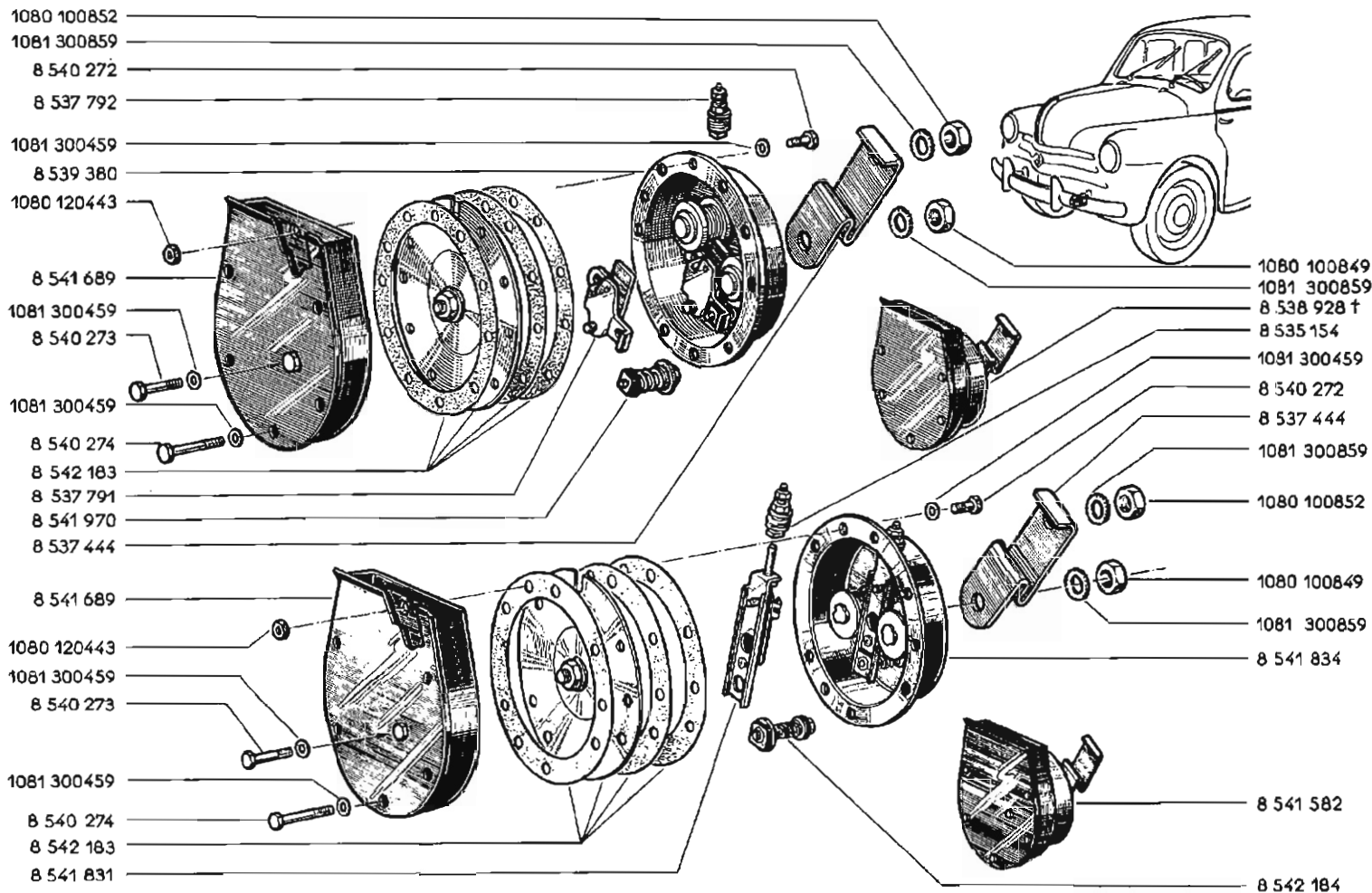

62.54

A P.R. 685

KLAXON

62.54

A P.R. 685

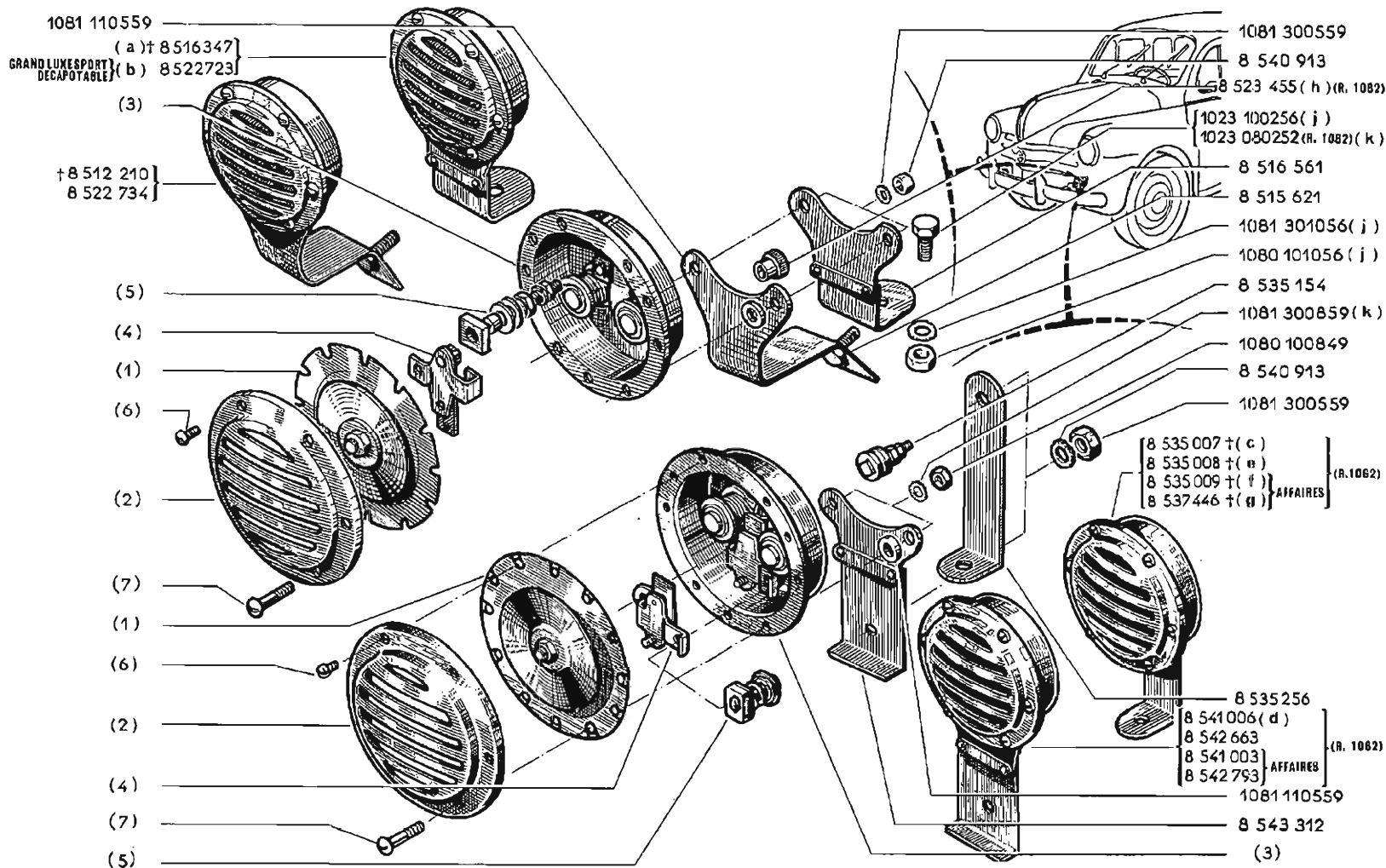

	XXXX 00000
32	08-00
81	08-00

	n°...	n°...	!!!
(a) R.1080 R.1082			
(b) R.1080 R.1082 R.1082	1 VEH 405601 VEH	405209 406426	
(c)	405210 VEH 406427 VEH	405600 ...	
(d)	406427 VEH	...	
(e)	405210 VEH 406427 VEH	405600 577929	
(f)	405210 VEH 406427 VEH	405600 577891	81
(g)	577892 VEH	...	81
(h)	1 VEH 405601 VEH	405209 406426	
(j) R.1080 R.2070 R.2071 R.1082	1 VEH	532892	32
(k)	532893 VEH	...	32



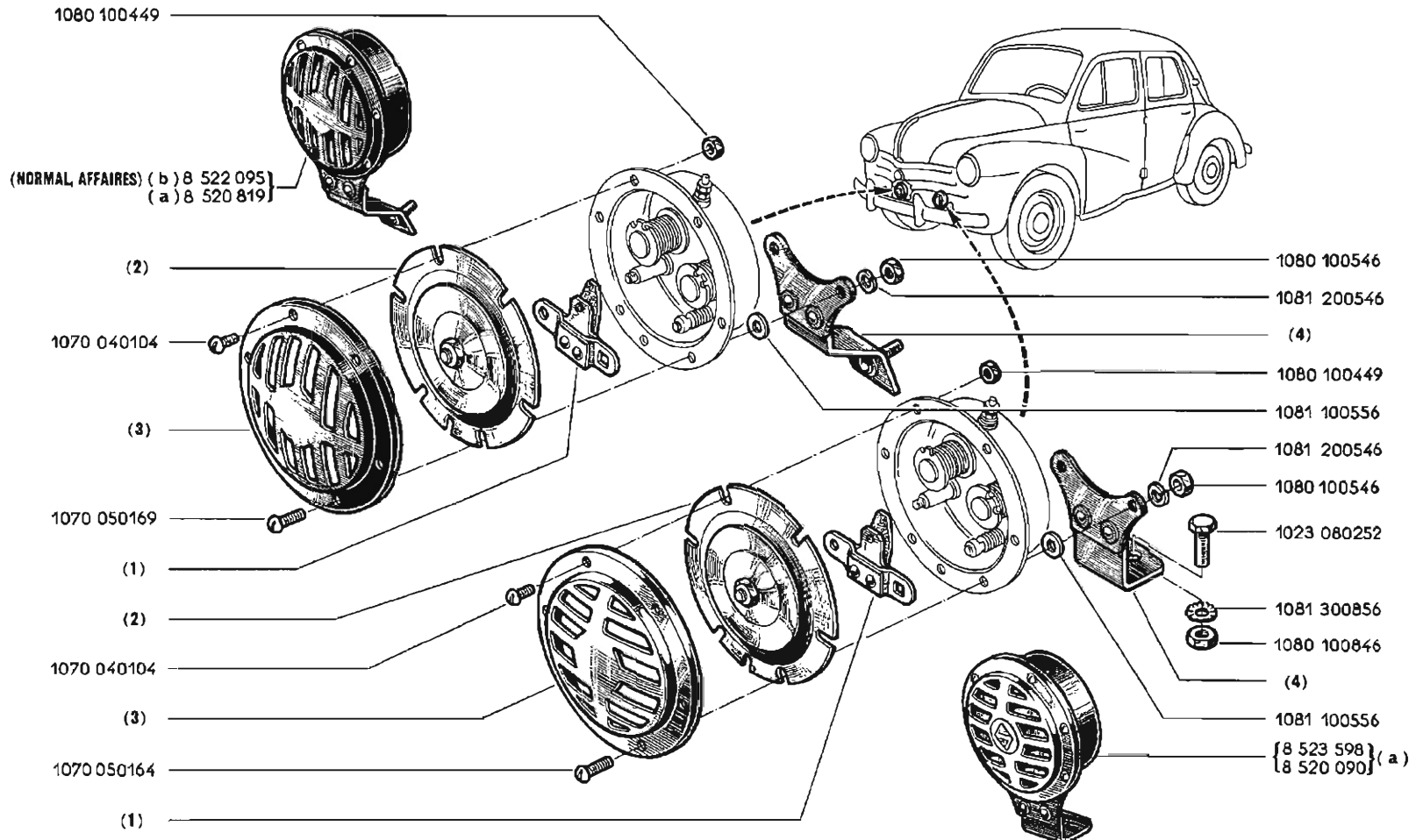

(a)	R 1060	{	VEH n°	1	⇨	VEH n° 405209
	R 1062		VEH n° 405601	⇨	VEH n° 406426	
(b)	R 1060	{	VEH n°	1	⇨	VEH n° 405209
	R 2070		VEH n° 405601	⇨	VEH n° 406426	
	R 2071					

	8522095	8520819	8523598	8520090
(1)	8524877	8521611	8524877	8521611
(2)	8524879	8521612	8524878	8521610
(3)	8524881	8545182	8524880	8545181
(4)	8524963	8523653	8524964	8523654

1080 100449

(a) 8 538 171

8 538 636

8 538 635

1070 040104

8 538 637

1023 080 252

1081 300 856

1080 100846

1070 040104

8 538 640

8 538 635

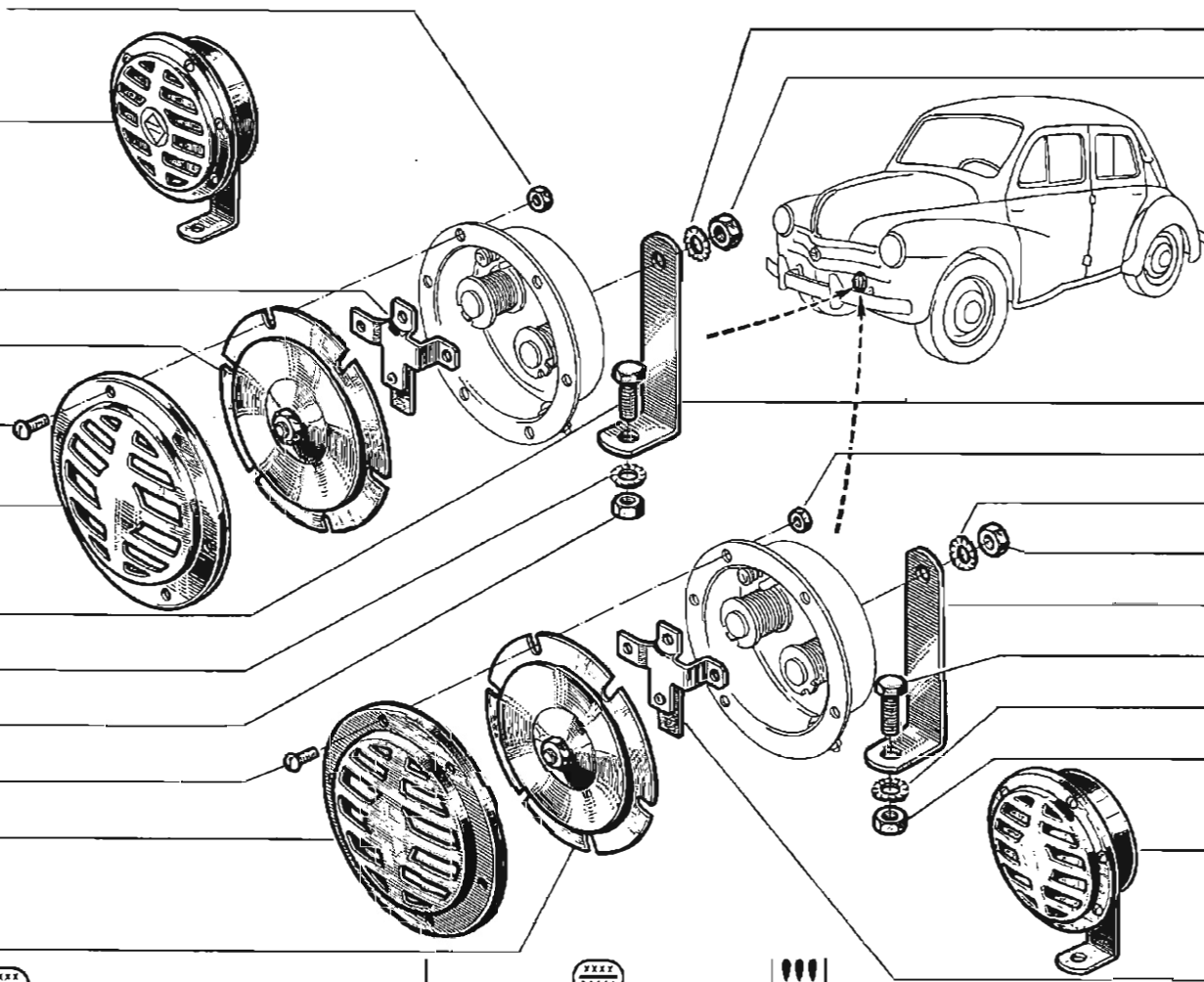

1081 300856

1080 100846

8 538182

1080100449

1081 300856

1080 100846

8 538182

1023 080252

1081 300856

1080 100846

8538172 AFFAIRES (b)

8 538636

81 08-00

	n°...	⇔	n°...	!!!
(a)	405210 VEH		405600	
(b)	577892 VEH		...	81

62.60

A P.R. 685

1081 300856

8 542 488

1023 040106

† 8 538 175
† AFFAIRES 8 538 930

8 538 636

8 538 647

8 539 434

8 542 998

FERSON (R. 1062 VEH. n° 577930 ⇔ VEH. n° ...)

62.60

A P.R. 685

1080 100852

1080 100846

1081 300856

1080 100852

1081 300856

1080 100846

1081 300856

8 542 488

1023 040106

8 542 996

8 542 482

8 542 997

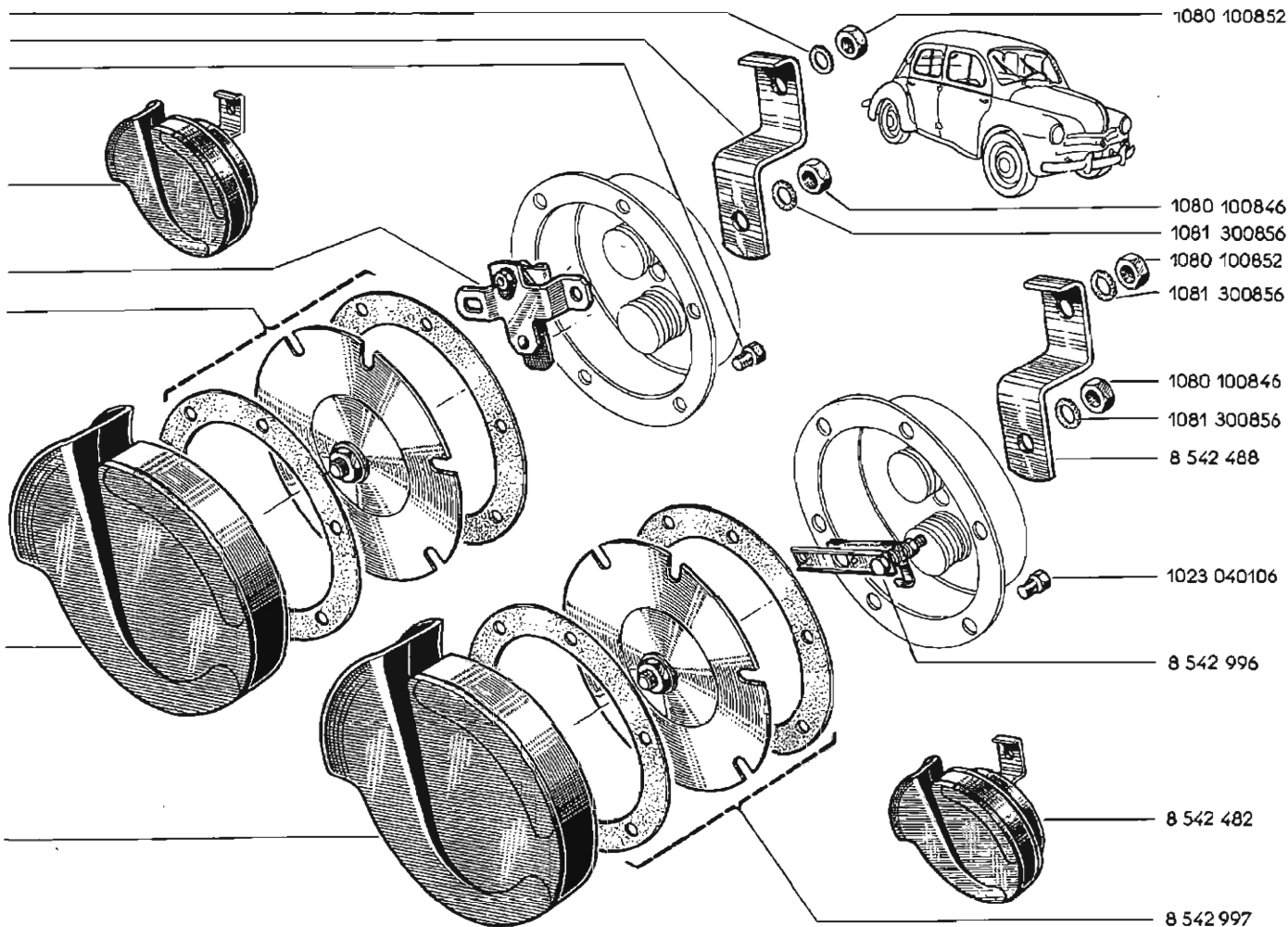

62.62

A P.R. 685

DUCELLIER

62.62

A P.R. 685

8517482
(1)
8517492
8517483

8517481
(2)
8517485
(2)
8517484
8517504

8517489

8517486
1080 100446
8516008 (a)

1080 100646
8517507
8517480
8517494

8517479

(3)

8517490
8517495
8517496
8517493
8517491

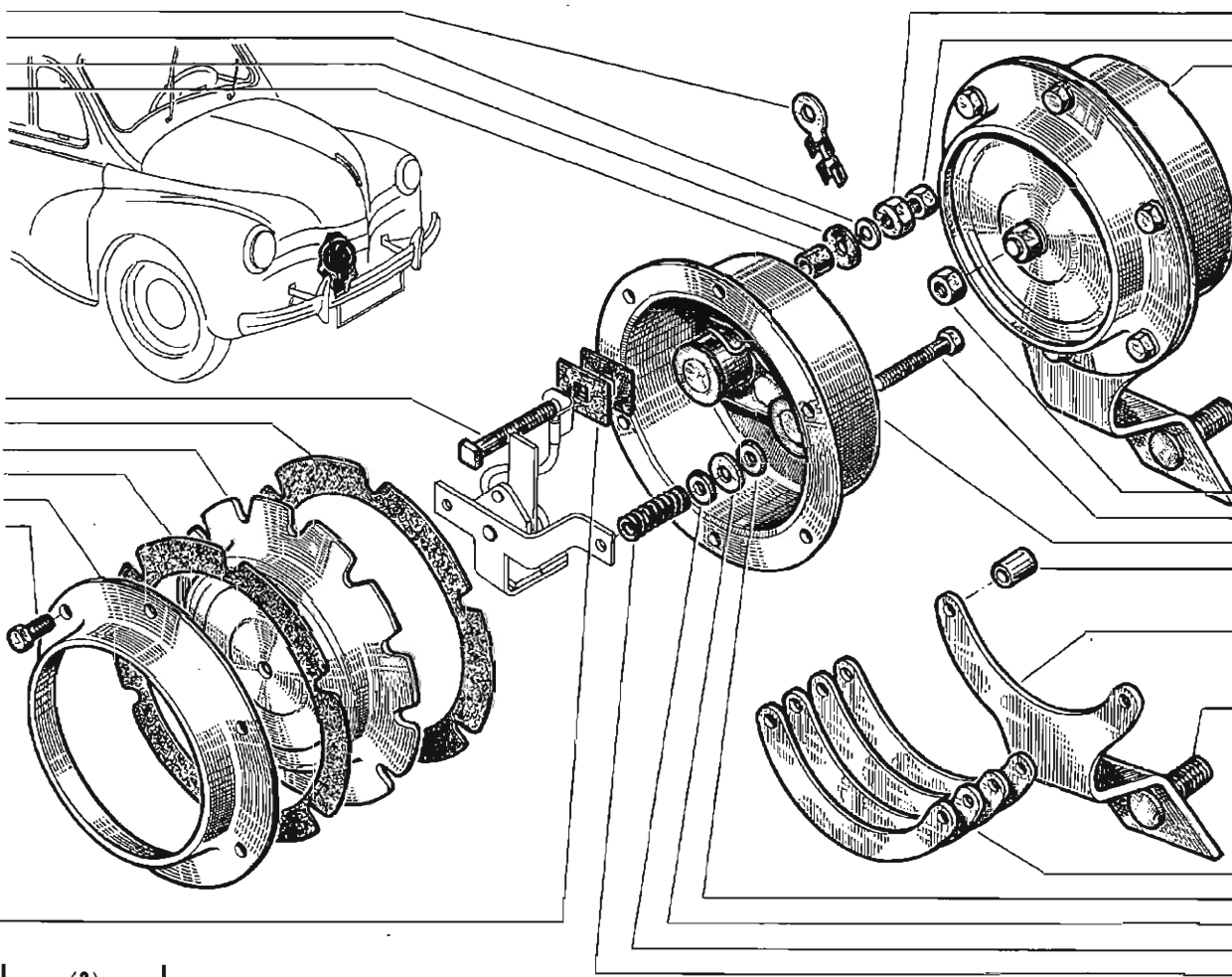

(2)	
8517499	E=0,2
8517500	E=0,25
8517501	E=0,4
8517502	E=0,15
8517503	E=0,05

(a)	
R 1060	R 1062 (AFFAIRES VEH n° 1 ⇨ VEH n° 405209, VEH n° 405601 ⇨ VEH n° 406426)
R 2070	
R 2071	

(1)	(3)
8517497 D=4,5	8517505 D=10
8517498 D=6,5	8517506 D= 6

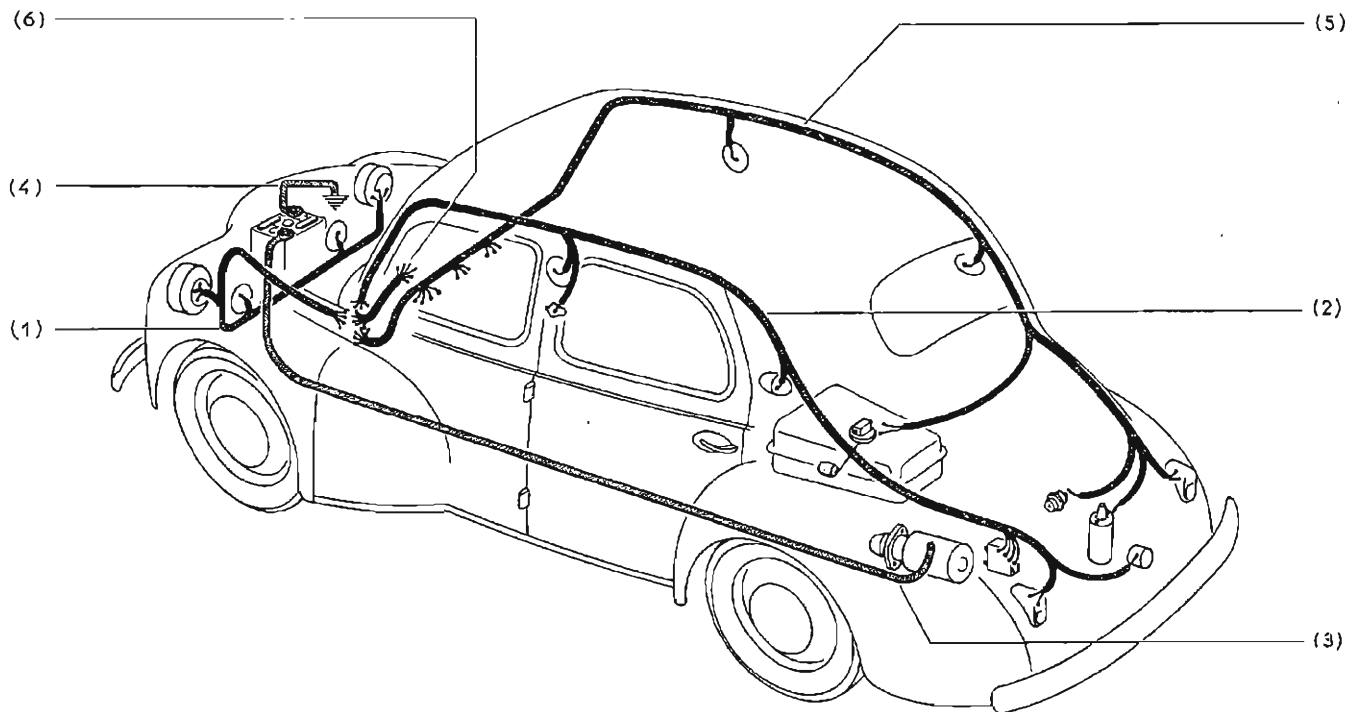

-
- 9 830 301 † (R. 1060)(R. 2070)
 - 9 830 291 † (R. 1080)
 - 9 830 290 † (R. 1080)
 - 9 830 316 † (b) NORMAL
 - 9 830 412 † (c) (R. 1062) NORMAL
 - 9 830 414 † (d)
 - 9 830 310 † (e)
 - 9 830 357 † (f) GRAND LUXE
 - 9 830 416 † (g)
 - 9 830 359 † (f)
 - 9 830 737 (h) } DÉCAPOTABLE
 - 9 830 408 (j) (R. 1062) } DÉCAPOTABLE
 - 9 830 701 † (R. 1062) SERVICE (k)
 - 9 830 736 (l) (m)
 - 9 830 738 (m)

	9830301	9830291	9830290	9830316	9830310	9830357	9830359	9830737
(1)	9830228 †	9830281 †	9830281 †	9830334 †	9830363 †	9830369 †	9830369 †	9502719
(2)	9830280 †	9830280 †						
(3)	9830232 †	9830232 †	9830232 †	9830232 †	9830232 †	9830232 †	9830232 †	9502729
(4)	9830233 †	9830233 †	9830233 †	9830233 †	9830233 †	9830233 †	9830233 †	
(5)		9830279 †	9830279 †	9830335 †				
(6)		9830278 †	9830231 †	9502734 †	9830231 †	9830370 †	9830374 †	9502728
						9830374 †		

	9830736	9830738	9830412	9830414	9830416	9830408	9830701
(1)	9502719		9502731 †	9502731 †	9502731 †	9502731 †	
(2)	9502720	9502720		9502720	9502720		
(3)	9502729	9502729	9502729	9502573 †	9502573 †	9830232 †	9502573 †
(4)				9502764 †	9502764 †	9830233 †	9502574
(5)							9502570 †
(6)	9502728	9502748 †	9502734 †		9830484 †	9830484 †	9502761

	n°...	n°...	!!!	!!!
(b) R.1060				164
R.2070				164
R.1062	1 VEH	3530	71	164
R.2071	1 VEH	165		164
(c)	3531 VEH	...		71 164
(d) R.1062 NORMAL	3531 VEH	...		71 164
R.2071	166 VEH	...		164
R.1062 LUXE	5101 VEH	...		164
R.1062 AFFAIRES	5101 VEH	...		164
(e) R.1060 LUXE				164
R.1062 LUXE	1 VEH	5100		164
R.1062 AFFAIRES	1 VEH	5100		164
(f) R.1060				164
R.1062	1 VEH	5100		164
(g) R.1062 GD LUXE	5101 VEH	...		164
R.1062 SPORT	5101 VEH	283715		164
(h) R.1060				164
R.1062	1 VEH	283715		164
(j)	5101 VEH	283715		164
(k)				164
(m) R.1060 LUXE				
R.1060 TOIT OUVRANT				
R.1062 LUXE	1 VEH	283715		
R.1062 SERVICE	1 VEH	283715		
R.1062 TOIT OUVRANT	1 VEH	283715		
R.2070				
R.2071				

71

08-00

164

08-00

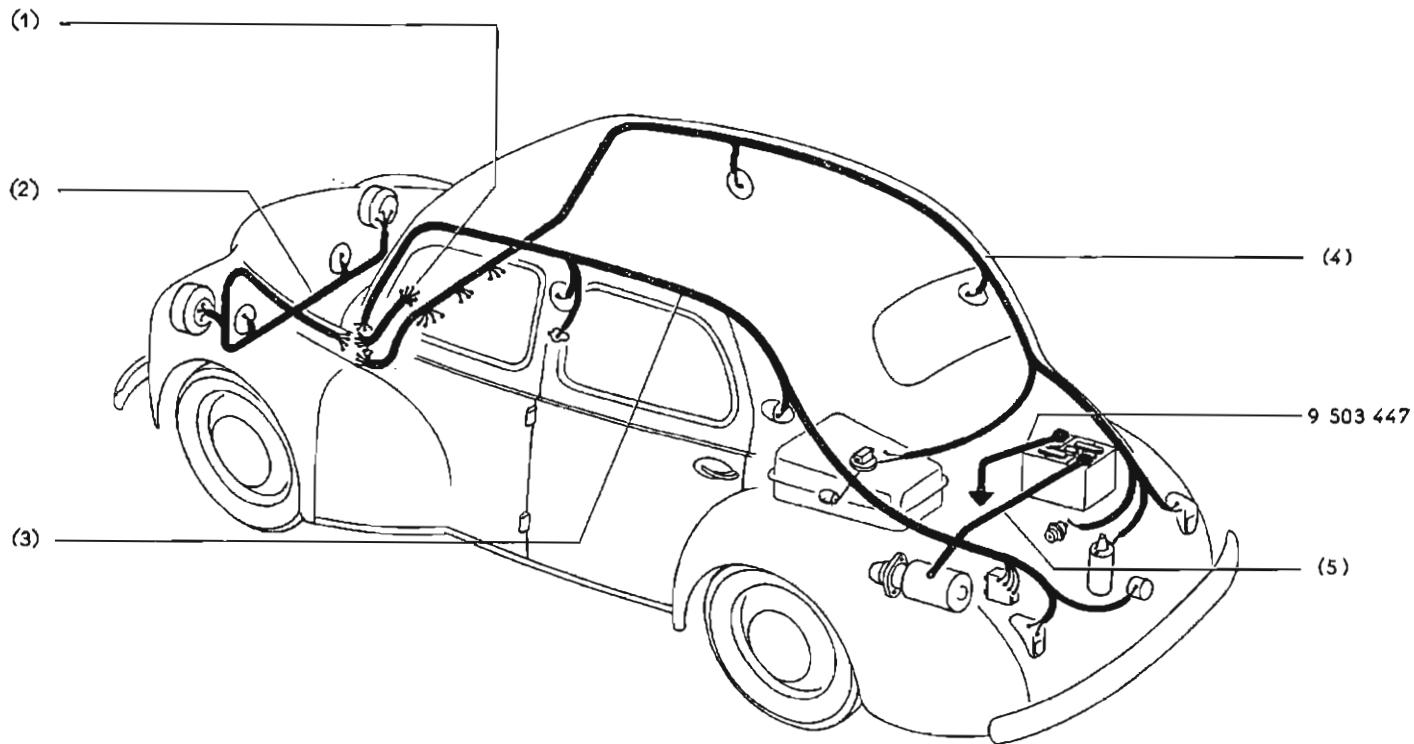

- (a) VEH n° 283716 ⇔ VEH n° 703420
- (b) VEH n° 283716 ⇔ VEH n° 869015
- (c) VEH n° 840861 ⇔ VEH n° 869015
- (d) VEH n° 1-11-1959 ⇔ VEH n° ...

- 9 830 951†
- 9 830 987†
- 9 836 043† (a)
- 9 830 989†
- 9 836 045† (a)
- 9 836 170†
- 9 836 171† SOFICA } (b)
- 9 836 389†
- 9 836 390† SOFICA } «D» «A» (c)
- 9 836 451
- 9 836 452 SOFICA } «DK» (d)

	9830989	9836045	9836170	9836171	9836451	9836452	9836389	9836390
(1)								
(2)	9503517	9503517	9503517	9503517	9504330	9504330	9504185	9504185
(3)	9503386	9503386	9503773	9503773	9504327	9504327	9503773	9503773
(4)	9503387	9503387	9503387	9503774	9504331	9504332	9504186	9504187
(5)	9503380	9503380	9503380	9503380	9503380	9503380	9503380	9503380

	9830951	9830987	9836043
(1)		9503379	9503516
(2)	9503132 + 9502748 +	9503374	9503374
(3)	9503301	9503383	9503375
(4)	9503302 +	9503384 +	
(5)	9503136 +	9503380	9503380

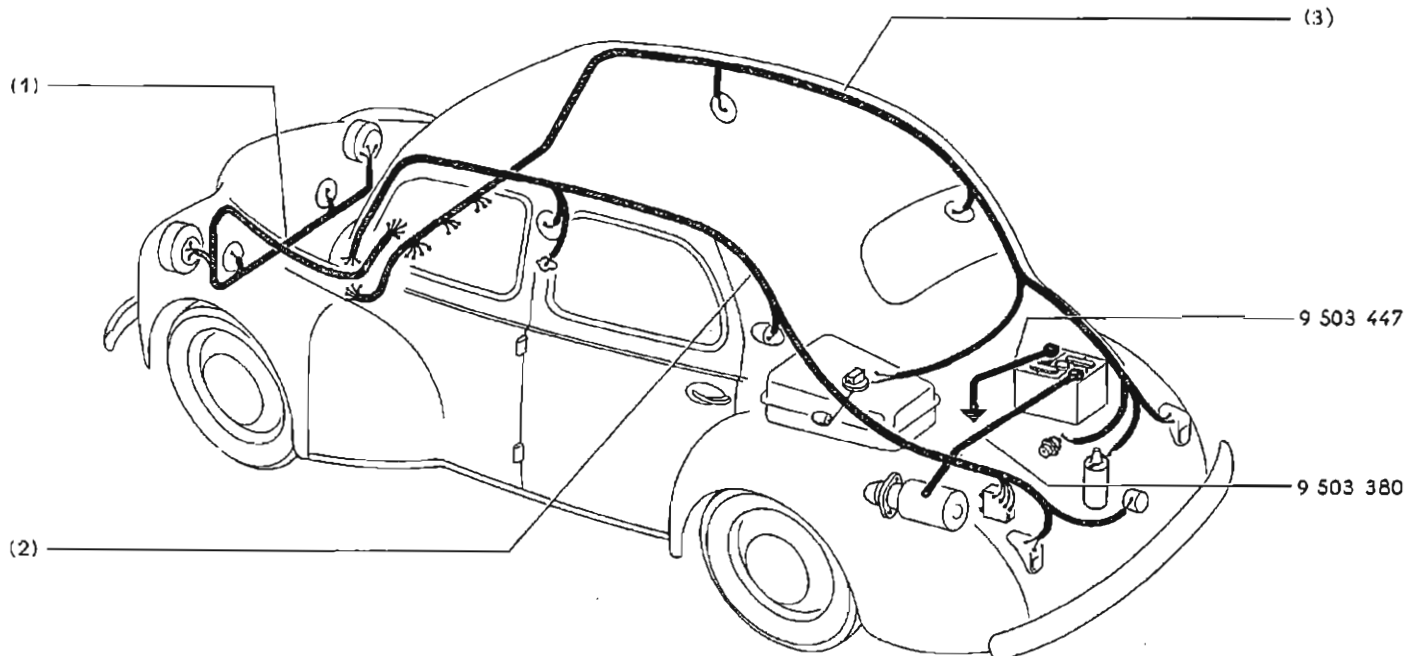

9 836 447
 9 836 448 SOFICA } (a)
 9 836 559 (b)
 9 836 560 SOFICA } «DK»
 9 836 449 †
 9 836 492
 9 836 450 † } «D» «A» (a)
 9 836 493 } SOFICA

(a) VEH n° 869016 ⇨ VEH n° ...
 (b) VEH n° 904447 ⇨ VEH n° ...

	9836447	9836448	9836559	9836560	9836449	9836492	9836450	9836493
(1)	9504324	9504324	9504438	9504438	9504324	9504373	9504324	9504373
(2)	9503773	9503773	9504327	9504332	9504328	9504374	9504329	9504375
(3)	9504325	9504326	9504331					

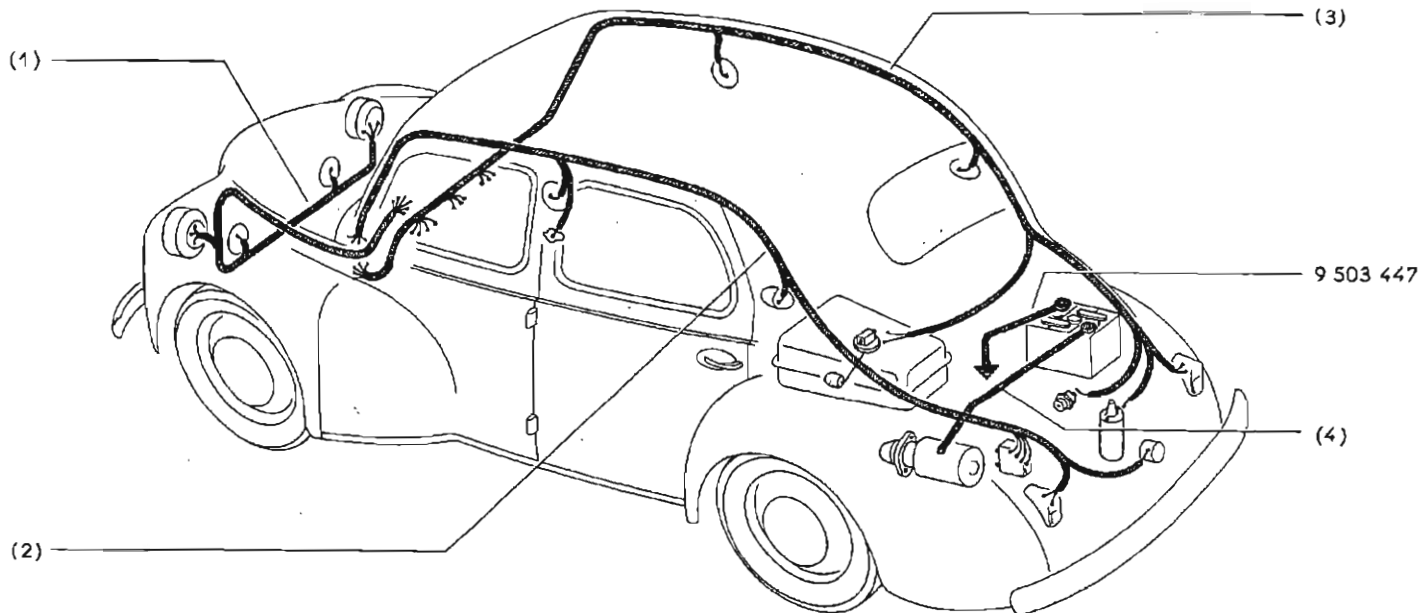

	9836051	9830952	9830992	9836453	9836177	9836264	9836454	9836573
(1)	9503520	9503132 †	9503374	9503520	9503520	9503520	9503520	9503520
(2)	9503405	9503303	9503402	9503881	9503779 †		9503881	9504489
(3)	9503406 †	9503302 †	9503384 †	9504333	9503780 †		9504334	9504490
(4)	9503380	9503136 †	9503380	9503380	9503380		9503380	9503380

	9836048	9830994	9836050	9836176	9836263	9830995
(1)	9503519	9503377	9503520	9503520	9503520	9503377
(2)	9503398			9503779 †		
(3)	9503399	9503406 †	9503406 †	9503406 †	9503882 †	9503406 †
(4)	9503380	9503380	9503380	9503380	9503380	9503380

9 830 952 †
 9 830 992 †
 9 830 994 †
 9 836 048 † } (a)
 9 836 050 † }
 9 836 051 (258)
 9 836 176 †
 9 836 263 † } (b)
 9 836 177 † SOFICA }
 9 836 264 † SOFICA (c)
 9 836 454 (d)
 9 836 573 «AUS» } (e)
 9 836 453 }
 9 830 995 † ‡

(a) VEH n° 283716 ⇨ VEH n° 703420
 (b) VEH n° 703421 ⇨ VEH n° 734970
 (c) VEH n° 734971 ⇨ VEH n° 869015
 (d) VEH n° 869016 ⇨ VEH n° ...
 (e) VEH n° 836974 ⇨ VEH n° ...

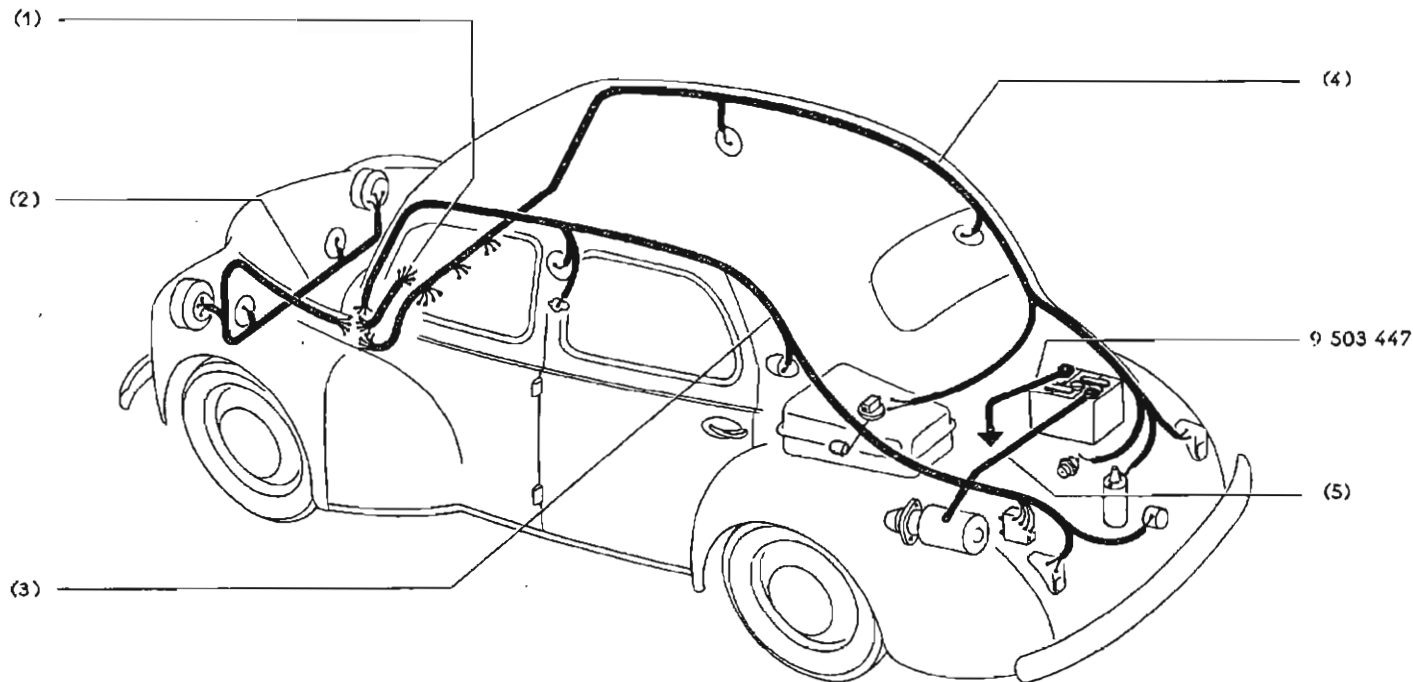

- (a) VEH n° 283716 ⇨ VEH n° 734970
 (b) VEH n° 1-11-1959 ⇨ VEH n° ...
 (c) VEH n° 283716 ⇨ VEH n° 703420

- 9 830 893 † }
 9 830 988 † } DÉCAPOTABLE
 9 836 044 }
 9 836 432 }
 9 836 433 SOFICA } «DR» (b)
 9 836 043 † (c)
 9 836 168 † (a)
 9 830 951 † }
 9 830 987 † }
 9 836 258 † } TOIT OUVRANT
 9 836 169 † (a) } SOFICA
 9 836 259 † }
 9 836 014 AUTOBLEU US }

	9830893	9830988	9836044	9835168	9836258	9836169	9836259	9836432
(1)	9502748 †	9503379	9503516	9503516	9503516	9503516	9503516	9504317
(2)	9503132 †	9503374	9503374	9503374	9503374	9503374	9503374	
(3)	9502769 †	9503383		9503770 †	9503816	9503770 †	9503816	9504310
(4)	9502770 †	9503384 †	9503384 †		9503817	9503772 †	9503877	9504316
(5)	9503136 †	9503380	9503380	9503380	9503380	9503380	9503380	9503380

	9836433	9830951	9830987	9836043	9836014
(1)	9504317	9502748 †	9503379	9503516	
(2)		9503132 †	9503374	9503374	
(3)	9504310	9503301	9503383	9503383	
(4)	9504320	9503302 †	9503384 †		
(5)	9503380	9503136 †	9503380	9503380	9503380

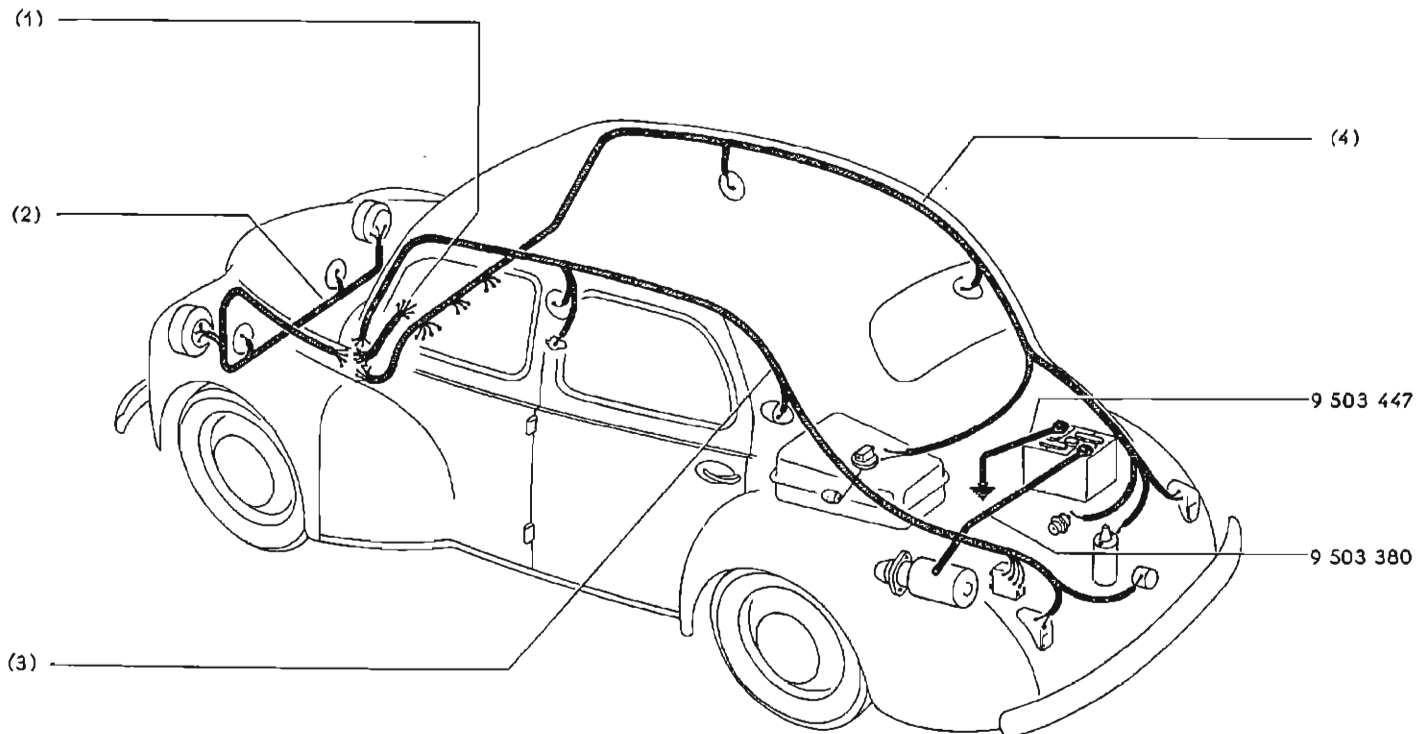

9 836 411 SOFICA } TOIT OUVRANT
 9 836 410 }
 9 836 437 }
 9 836 438 SOFICA
 9 836 495 «CH» (a)
 9 836 557 }
 9 836 558 SOFICA } «DK» (b)

(a) VEH n° 894652 ⇨ VEH n° ...
 (b) VEH n° 904447 ⇨ VEH n° ...

	9836411	9836410	9836437	9836438	9836495	9836557	9836558
(1)			9503516	9503516		9504317	9504371
(2)	9504304	9504304					
(3)	9503816	9503816	9503816	9503816	9504369	9504310	9504310
(4)	9504305	9504303	9503817	9503877	9504376	9504316	9504320

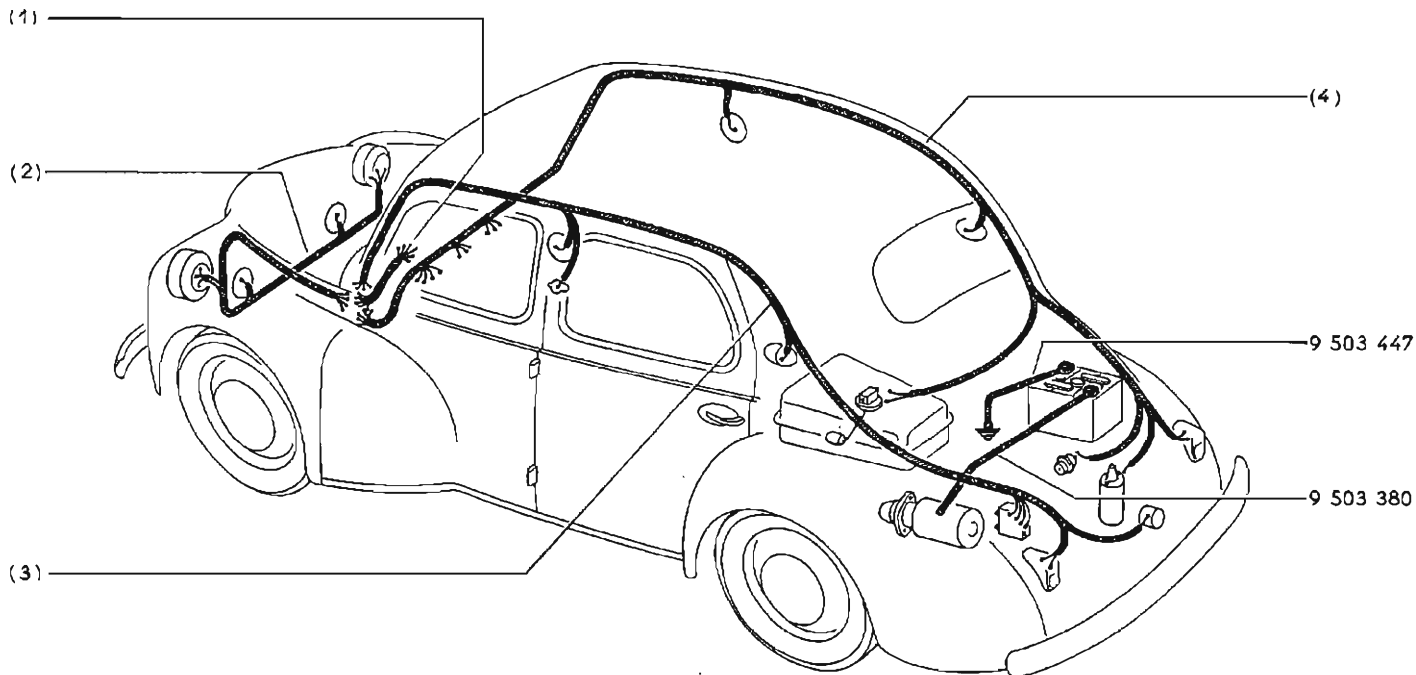

9 836 431 †
 9 836 440 † } SOFICA (a)
 9 836 491 }
 9 836 387 † (b)
 9 836 413 †
 9 836 439 †
 9 836 490
 9 836 388 † SOFICA ■

(a) VEH n° 869016 ⇨ VEH n° ...
 (b) VEH n° 840861 ⇨ VEH n° 869015

	9836431	9836440	9836491	9836387	9836413	9836439	9836490	9836388
(1)	9504312	9504183	9504371	9504183	9504312	9504183	9504371	9504183
(2)				9504180				9504180
(3)	9504310	9503816	9504369	9503816	9504310	9503816	9504369	9503816
(4)	9504313	9504184	9504372	9504181	9504311	9504181	9504370	9504184

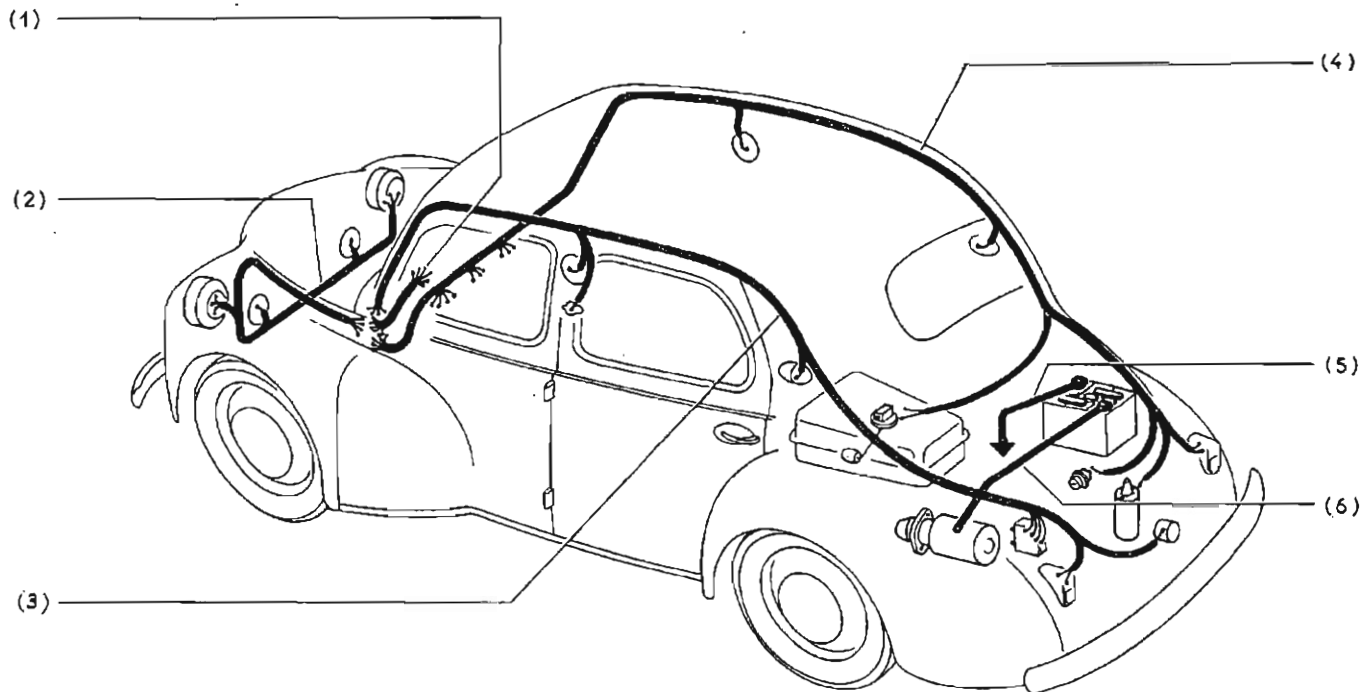

- (a) VEH n° 283716 ⇔ VEH n° ...
- (b) VEH n° 1 ⇔ VEH n° 734970
- (c) VEH n° 1 ⇔ VEH n° 840299
- (d) VEH n° 840300 ⇔ VEH n° 869015
- (e) VEH n° 869016 ⇔ VEH n° ...
- (f) VEH n° 283716 ⇔ VEH n° 703420

- 9 830 965 †
 - 9 830 991 †
 - 9 836 047 †
 - 9 830 953 †
 - 9 830 990 †
 - 9 836 172 †
 - 9 836 173 †
 - 9 836 260 †
 - 9 836 282 †
 - 9 836 412 ☒
 - 9 836 441 ☒
 - 9 830 786 † (164)
 - 9 836 046 †
- } DÉCAPOTABLE (a)
 } SOFICA (b)

	9830965	9830991	9836047	9830953	9830990	9836172	9836173	9836260
(1)		9503379	9503518		9503379	9503518	9503518	9503518
(2)		9503374	9503374		9503374	9503374	9503374	9503374
(3)		9503395	9503395			9503775 †	9503775 †	
(4)	9502770 †	9503396	9503396		9503392	9503392	9503776 †	9503879
(5)	9503447	9503447	9503447	9503447	9503447	9503447	9503447	9503447
(6)	9503136 †	9503380	9503380	9503136 †	9503380	9503380	9503380	9503878

	9836282	9836412	9836441	9830786	9836046
(1)	9504105		9504105		9503518
(2)	9504102 †	9504309		9502758 †	9503374
(3)	9504103	9504103	9504103		
(4)	9504104	9504308	9504104		9503392
(5)	9503447	9503447	9503447	9502764	9503447
(6)	9503380	9503380	9503380	9502573 †	9503380

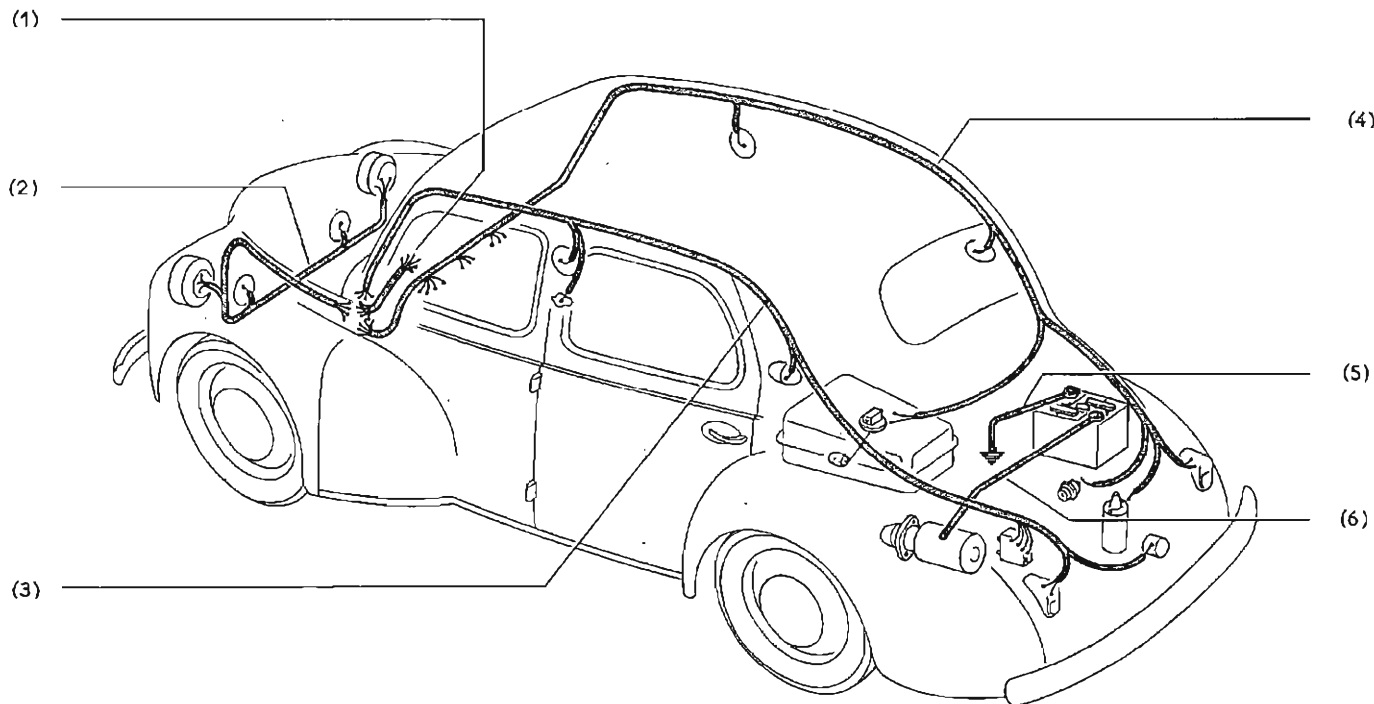

- (a) VEH n° 836974 ⇨ VEH n° ...
- (b) VEH n° 703421 ⇨ VEH n° 734970
- (c) VEH n° 283716 ⇨ VEH n° 869015
- (d) VEH n° 869016 ⇨ VEH n° ...
- (e) VEH n° 1 ⇨ VEH n° 869015
- (f) VEH n° 283716 ⇨ VEH n° 703420
- (g) VEH n° 283716 ⇨ VEH n° ...

- 9 836 572 « AUS » (a)
- 9 836 048 † (f)
- 9 836 174 † (b)
- 9 836 261 † (c)
- 9 836 434 (d)
- 9 836 175 †
- 9 836 262 † (e)
- 9 836 446 (d)
- 9 830 895 †
- 9 830 993 †
- 9 836 049

TOIT OUVRANT

SOFICA

DÉCAPOTABLE (g)

	9836572	9836174	9836261	9836434	9836175	9836262	9836446	9830895
(1)	9504488	9503519	9503519	9504322	9503519	9503519	9504322	
(2)	9504180	9503374	9503374		9503374	9503374		9503132 †
(3)	9504486	9503777	9503777	9503777	9503777	9503777	9503777	9502769 †
(4)	9504487	9503399	9503399	9504321	9503778	9503778	9504323	9502770 †
(5)	9503447	9503447	9503447	9503447	9503447	9503447	9503447	9503447
(8)	9503380	9503380	9503380	9503380	9503380	9503380	9503380	9503136

	9830993	9836049	9830417	9836048
(1)		9503519		9503519
(2)	9503374	9503374		9503374
(3)	9503402	9503402		9503398
(4)	9503384 †			9503399
(5)	9503447	9503447	9502764 †	9503447
(6)	9503380	9503380	9502573 †	9503380

- (a) ● 9 836 002
- 9 830 976
- (b) † 9 836 381
- (d) 9 836 294

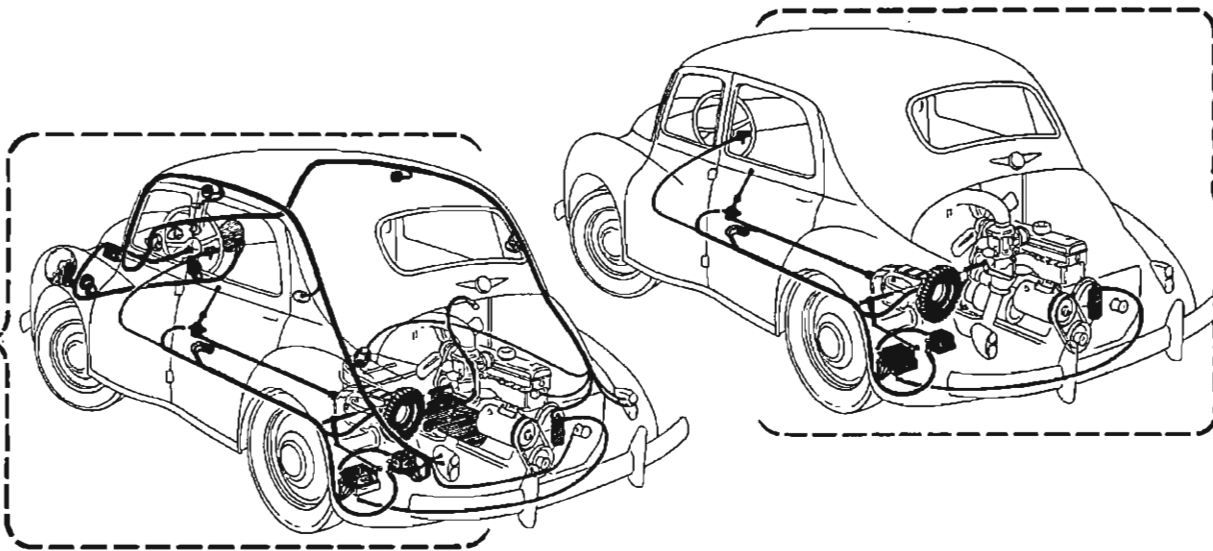

- 9 503 439 ● (a)
- 9 503 364
- 9 503 960 (d)
- 9 504 162 ● † (e)
- 9 504 161 † (b)

- (c) { 9 836 455
- 9 836 456 }

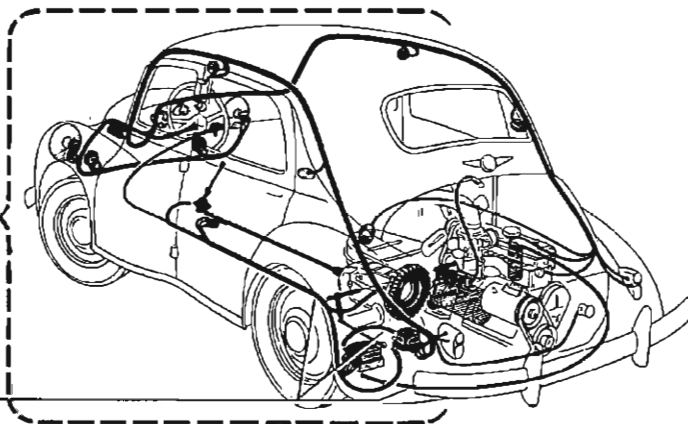

- (c) { 9 504 335
- 9 504 336 }

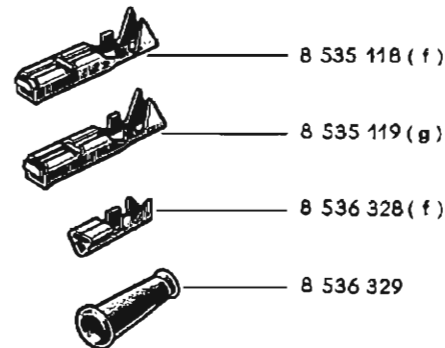



8 535 118 (f)



8 535 119 (g)

8 536 328 (f)

8 536 329

73	 08-00
87	 08-00

XXXX
00000



	n°...	n°...			
(a)	1 VEH	405603			
(b)	841460 VEH	869015	87		
(c)	869016 VEH	...			
(d)	769953 VEH	841459			
(e)	841460 VEH	...	87		
(f)	1 VEH	525338	73		
	525339 VEH	...			73
(g)	1 VEH	525338			73

XXXX
00000

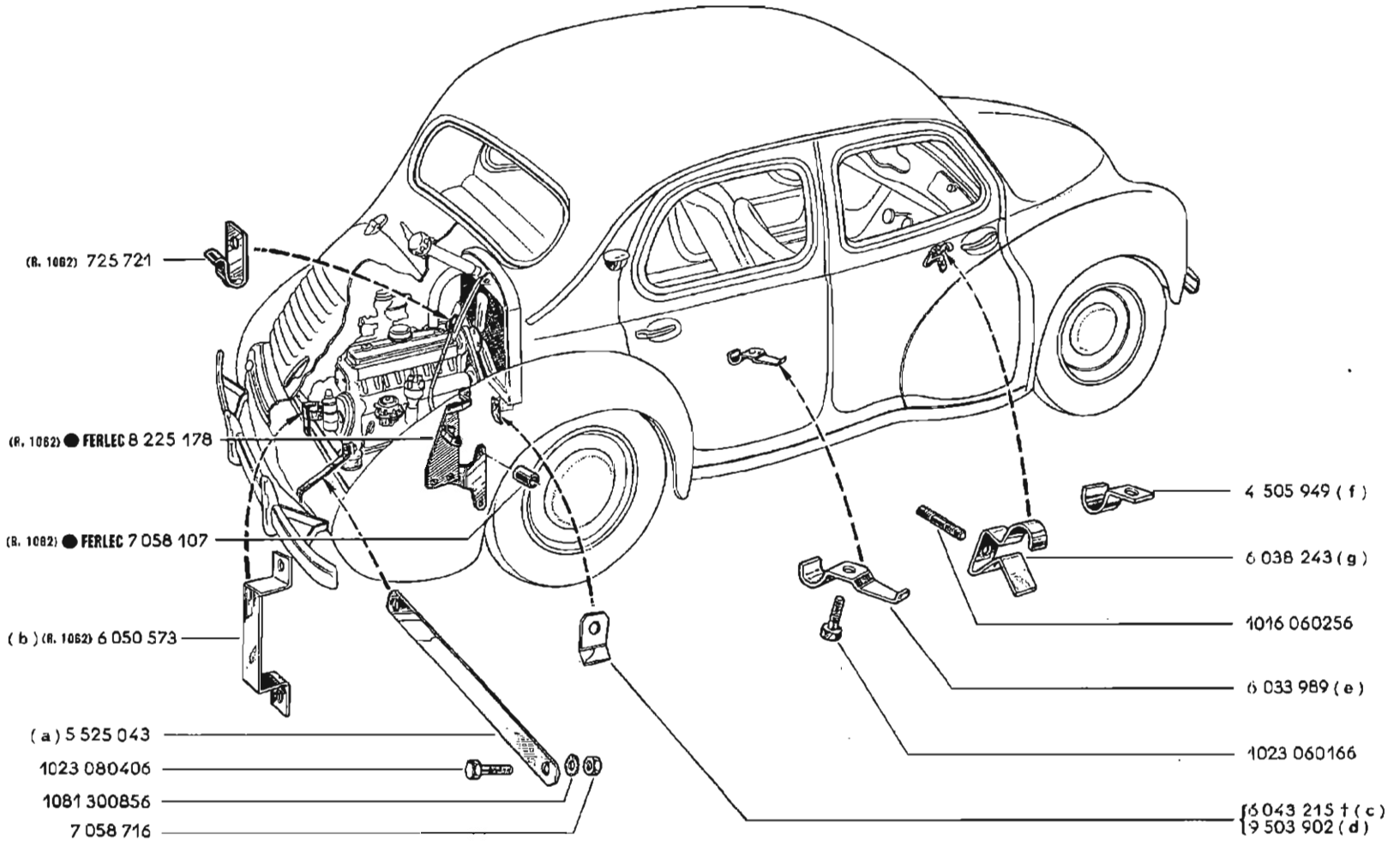

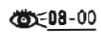
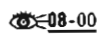

	
1	
2	

			
	n° ...	n° ...	
(a) R.1080 R.2070 R.2071 R.1062	1 VEH	333060	
(b)	333061 VEH	...	
(c) R.1080 R.2070 R.2071 R.1062	1 VEH	712483	
(d) R.1080 R.2070 R.2071 R.1062	712484 VEH	...	
(e) R.1080 R.2070 R.1062 R.2071	1 VEH 1 VEH	6340 353	
(f) R.1080 R.2070 R.1062 R.2071	1 VEH 1 VEH	69929 2524	2 1
(g) R.1062 R.2071	69930 VEH 2525 VEH	1 2



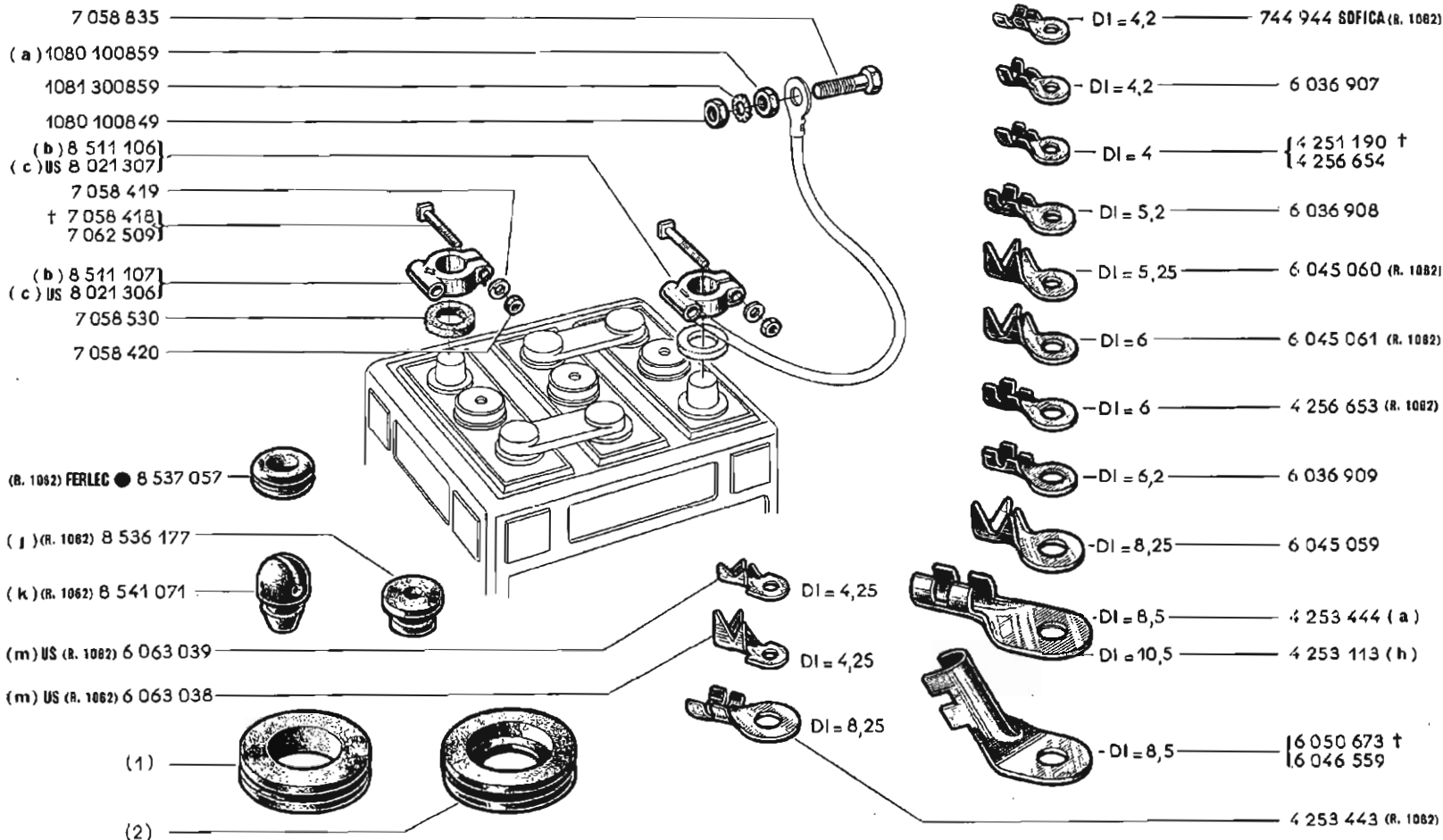

(1)	(2)
5483957 DI=10 mm DE=20 mm	5490347 DI= 5 mm DE=31 mm
(d) 4250954 DI=13 mm DE=28 mm	6053898 DI= 8 mm DE=31 mm (R. 1082)
(e) 713572 DI=28 mm DE=45 mm FERLEC	5490346 DI=16 mm DE=45 mm
(f) 6057228 DI=16 mm DE=45 mm FERLEC	4250753 DI=10 mm DE=45 mm (g)

	n°...	n°...	!!!
(a) R.1060 R.2070 R.2071 R.1062	1 VEH	538859	
(b) R.1060 R.2070 R.2071 R.1062 NORMAL R.1062 GRAND LUXE R.1062 SERVICE	1 VEH 1 VEH	3530 5100	
(c) R.1062 NORMAL R.1062 GRAND LUXE	3531 VEH 5101 VEH	
(d) R.1060 R.2071 R.1062 R.2070	6091 VEH 840 VEH	
(e) R.1062	1 VEH	734490	
(f) R.1062	734971 VEH	...	
(g) R.1060 R.2070 R.2071 R.1062	1 VEH	283715	
(h) R.1062	538860 VEH	...	
(j)	1 VEH	742155	
(k)	742156 VEH	...	
(m)	840300 VEH	...	

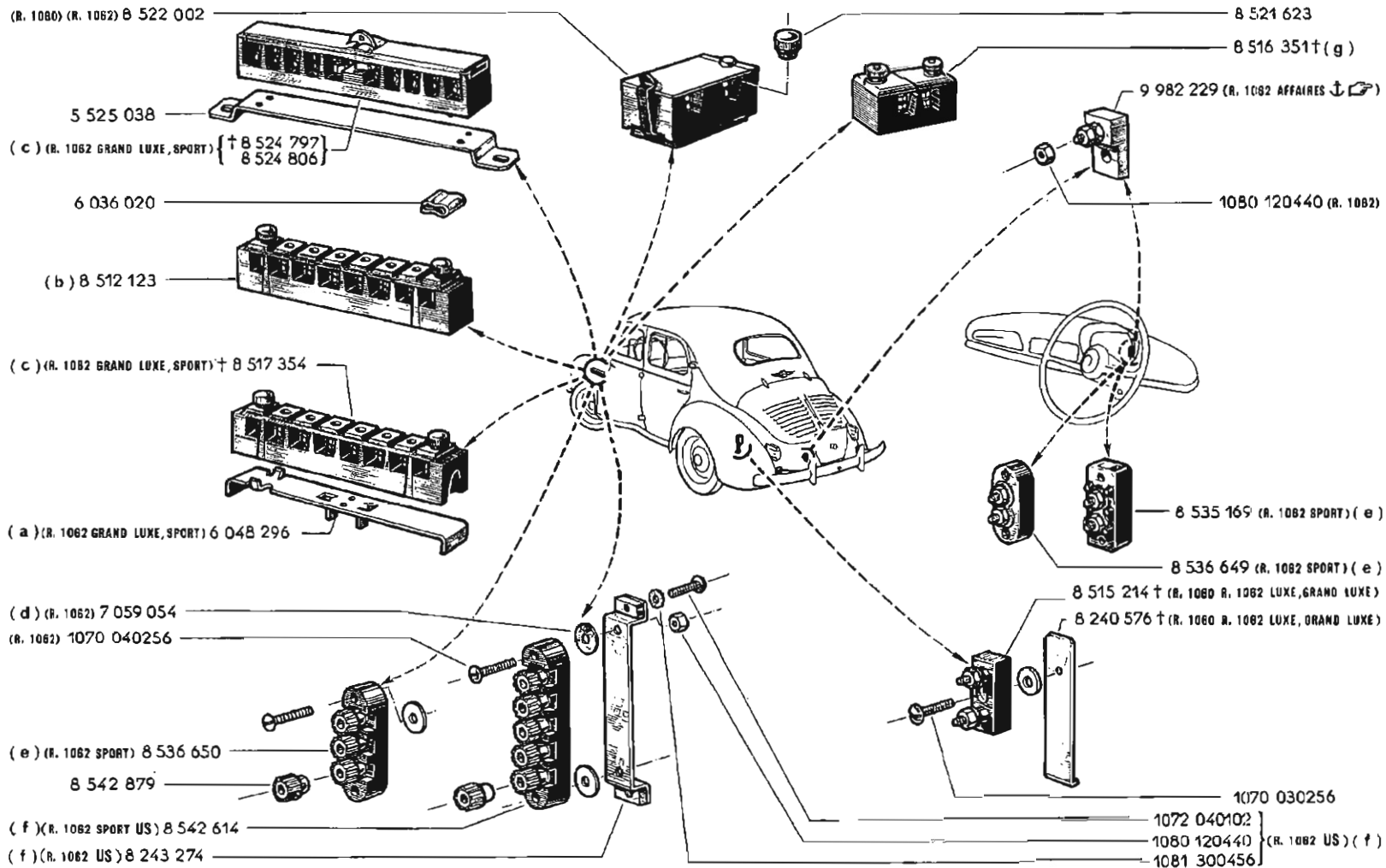

XXXX
00000

32	08-00
----	-------

	XXXX 00000	!!!
n°...	☞	n°...
(a)	371637 VEH	...
(b) R.1060		
R.1062	1 VEH	20885
R.2070	112350 VEH	...
R.2071	112350 VEH	...
(c)	20886 VEH	532892
(d)	532893 VEH	...
(e)	532893 VEH	...
(f)	840300 VEH	869015
(g) R.1060 GRAND LUXE		
R.1062 GRAND LUXE	1 VEH	20885

!!!

114	⚖️	6048286 -1- 1070 050406 -2- 1081 300556 -2-
-----	----	---



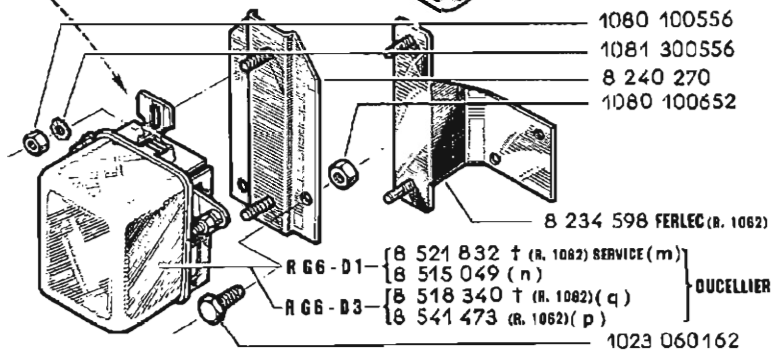
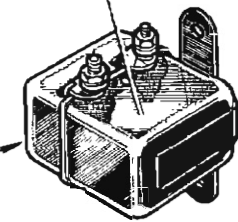
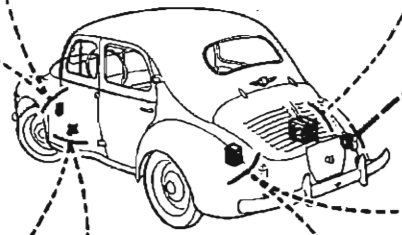
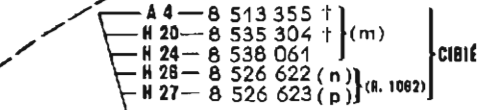
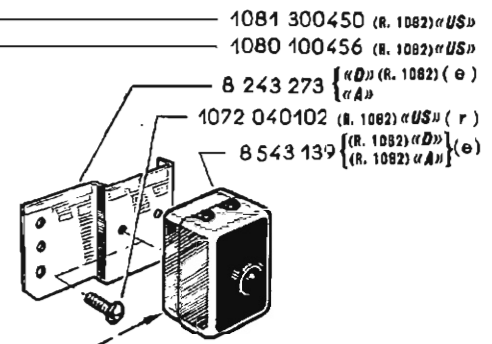
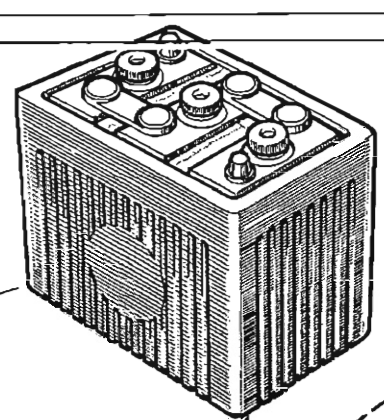
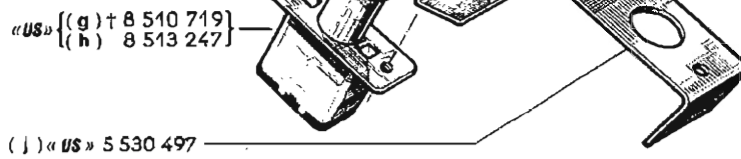
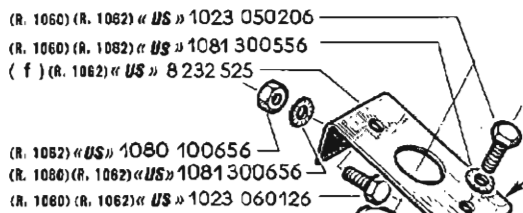
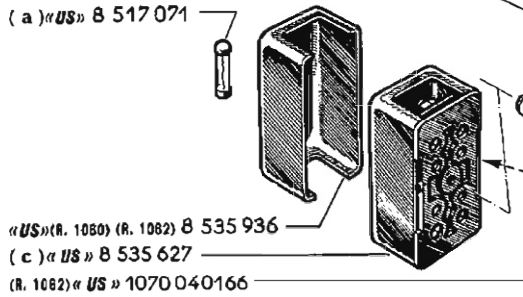
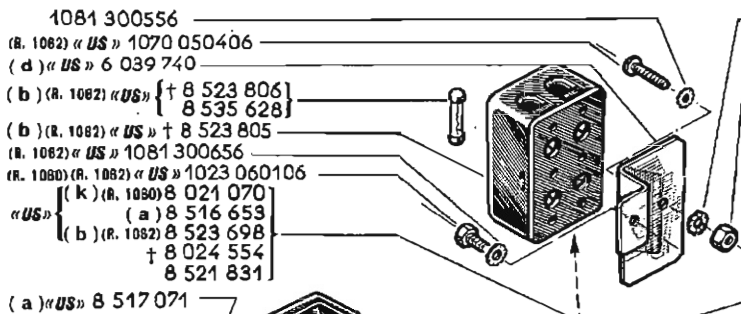

	n°...	⇒	n°...	⚡	⚡	!!!
(a) R.1080	112350 VEH		...			
R.1062	1 VEH		283715			
(b)	283716 VEH		...			
(c) R.1080	112350 VEH		...			
R.1082						
(d) R.1060	112350 VEH		...			
R.1082	1 VEH		405209			
R.1062	405601 VEH		406426			
(e)	840861 VEH		...			
(f)	67685 VEH		...			
(g) R.1080	112350 VEH		...			
R.1062	67685 VEH		...			
(h) R.1080	112350 VEH		...			115
R.1062	67685 VEH		...			115
(j) R.1060	112350 VEH		...			
R.1062	1 VEH		67684			
(k)	1 VEH		112349			
(m)						118
(n)	1 MOT		705121			116
(p)	705122 MOT		...			
(q)	705122 MOT		...			118
(r)	840300 MOT		869015			

!!!

115	⚡ 06-00
116	⚡ 06-00

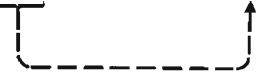

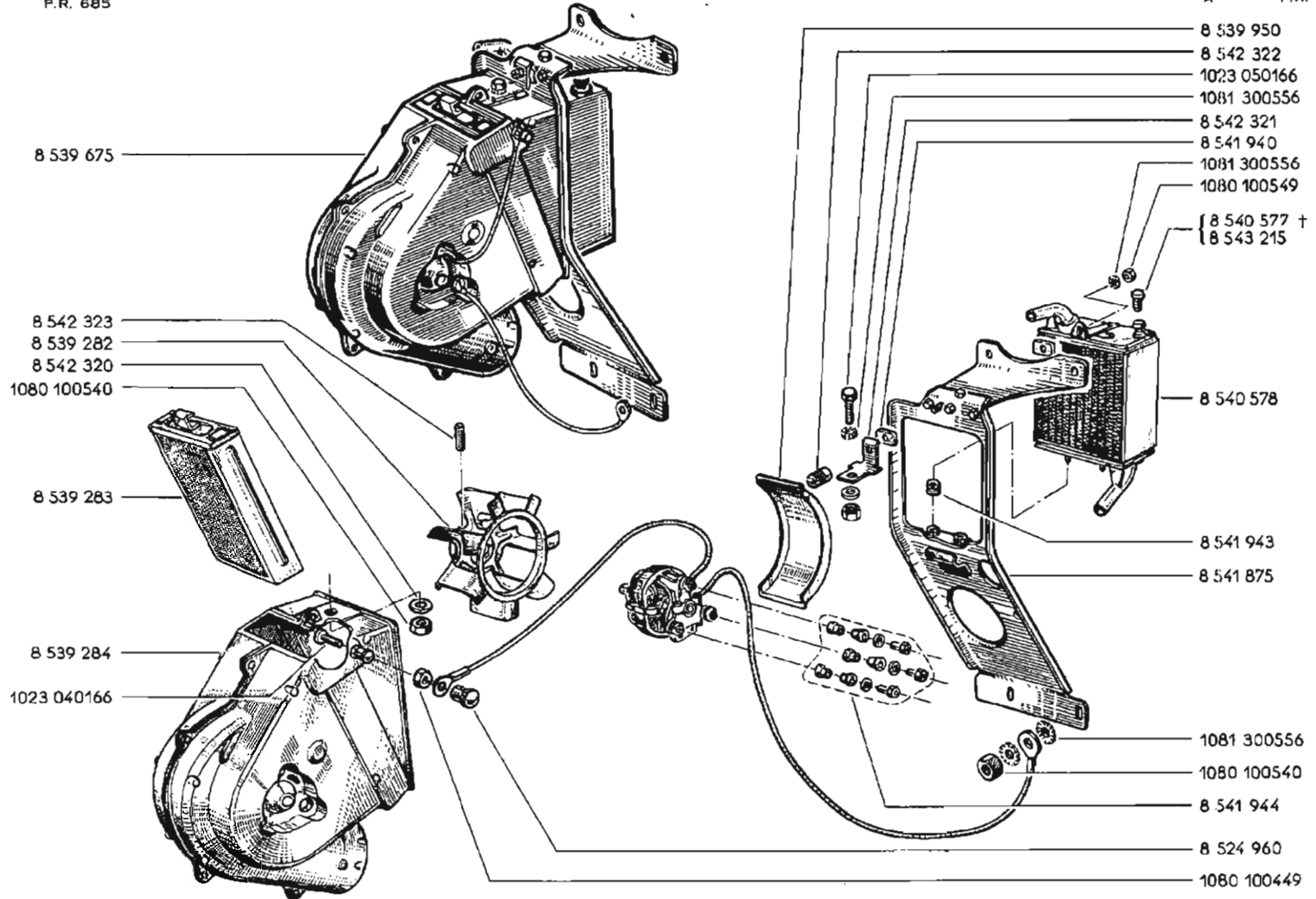

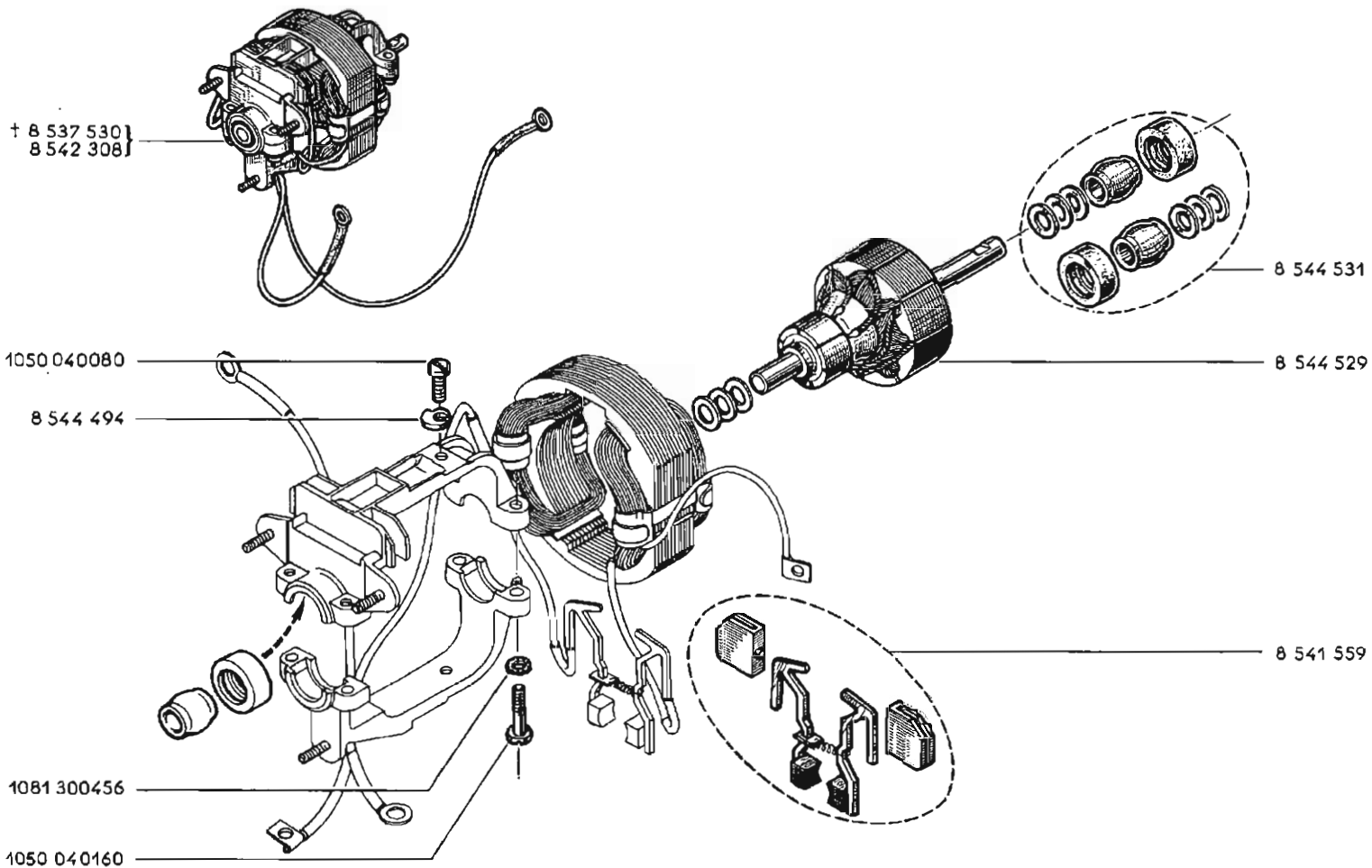

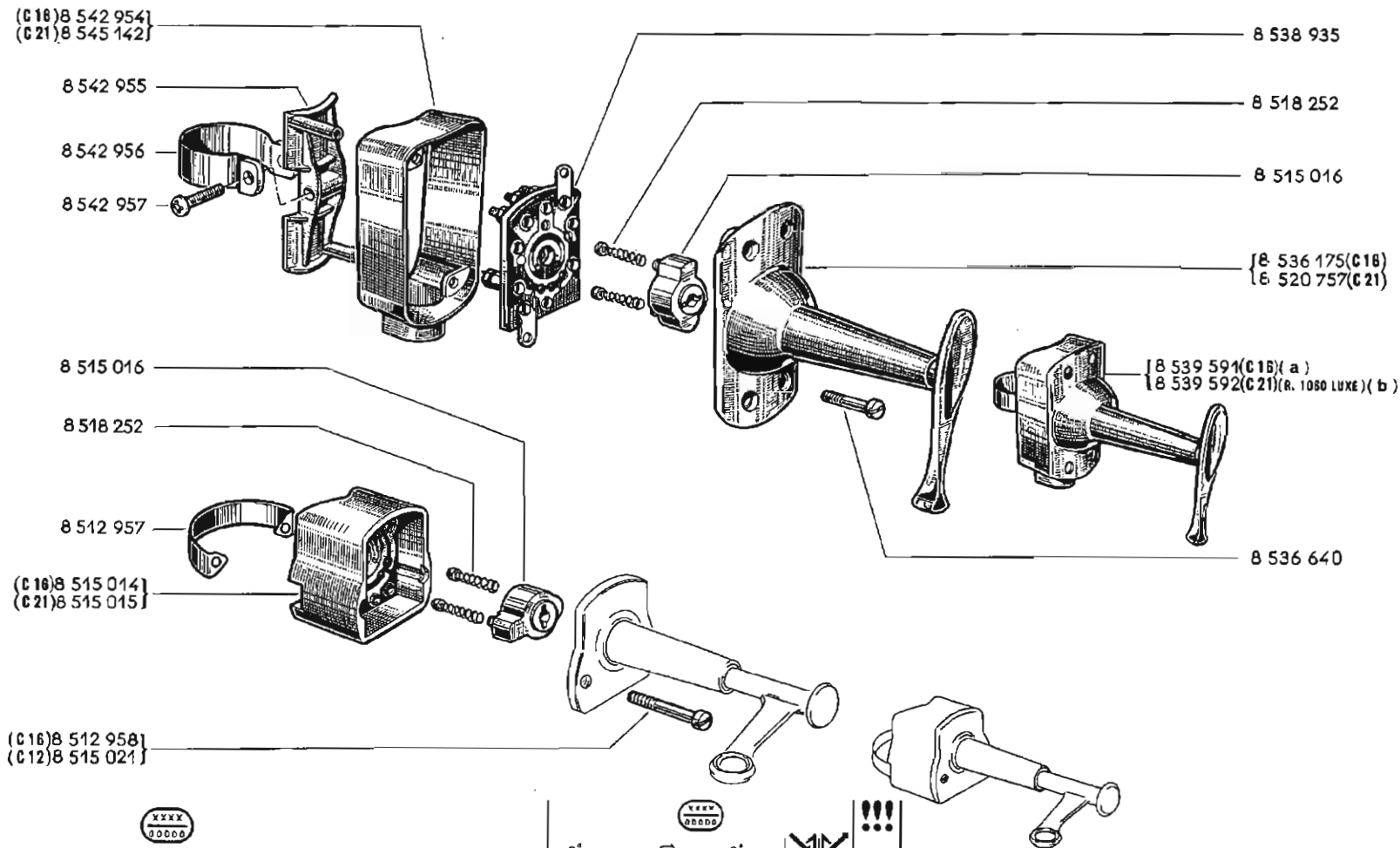

13 08-00

	n°...	n°...	!!!
(a) R. 1060	1 VEH	74349	13
R. 2070	1 VEH	8820	
(b)	1 VEH	64483	

C12 | 08-00
C18 |
C21 |

- (a) (C16) 8 515 041
- (b) (R. 1082) (C21) 8 515 042 71
- (c) (C17) 8 515 042 79
- US { (e) (C21) 8 516 650 71
- (d) (C17) 8 516 650 79

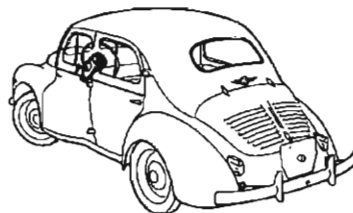
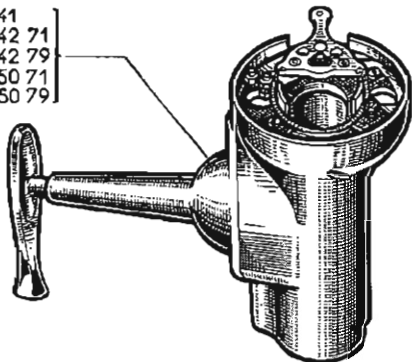

8 516 566



- 8 518 202 (C16)
- 8 516 049 71 (C21)
- 8 516 049 79 (C17)

8 515 016

- (C16) 8 536 175
- (C21) 8 520 757
- (C17) 8 536 175 79
- US { (C21) 8 518 251 71
- (C17) 8 518 251 79

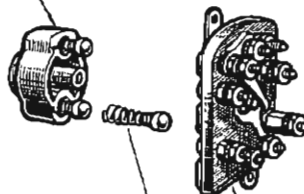
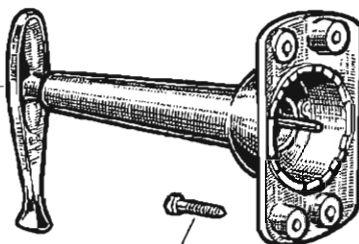

8 536 640

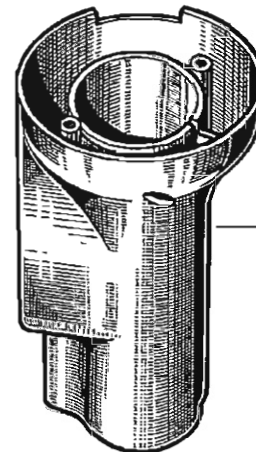

- 8 518 203 (C16)
- 8 516 050 71 (C21)
- 8 516 050 79 (C17)

- (C16) 8 518 201
- (C21) 8 520 756
- (C17) 8 516 048 79
- US { (C21) 8 518 253 71
- (C17) 8 518 253 79

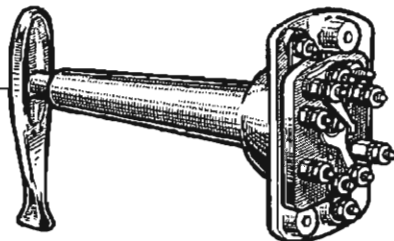



8 517 812

8 518 252

C16
C17
C21

100-00

	n°... 	n°... 	
(a) R.1060 NORMAL	77431 VEH	...	
R.1062 NORMAL			
R.2070	8841 VEH	...	
R.2071			
(b) SPORT DÉCAPOTABLE	405210 VEH	405600	
	406427 VEH	532892	32
(c) R.1060 LUXE, GRAND LUXE	64484 VEH	...	
R.1060 LUXE, GRAND LUXE «US»	1 VEH	112349	
R.1062 LUXE, AFFAIRES, GRAND LUXE			
R.1062 SPORT, DÉCAPOTABLE	1 VEH	405209	
R.1062 SPORT, DÉCAPOTABLE	405601 VEH	406426	
(d) R.1060 LUXE	112350 VEH	...	
R.1062	1 VEH	405209	
R.1062	405601 VEH	406426	
(e) R.1062	405210 VEH	405600	
R.1062	406427 VEH	532892	32

32  08-00



- US { (a) 8 537 502
(d) 8 537 506
(e) 8 542 629
(b) 8 544 229
(c) 8 544 353 }

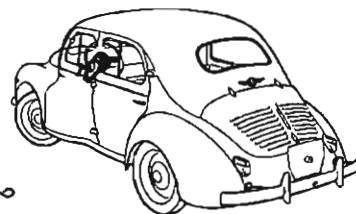
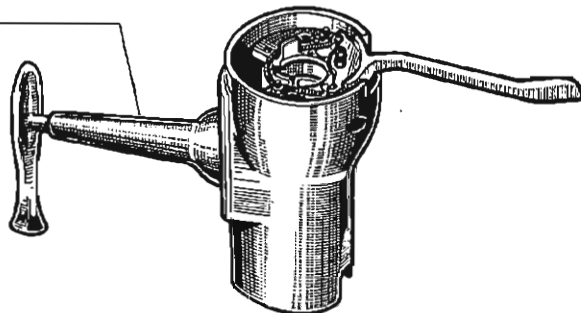

8 537 505

8 518 252

(5)

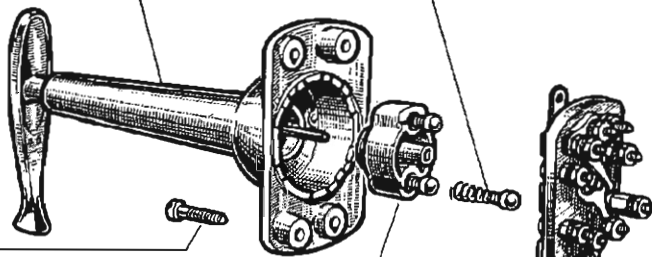

8 536 640

8 515 016

(1)

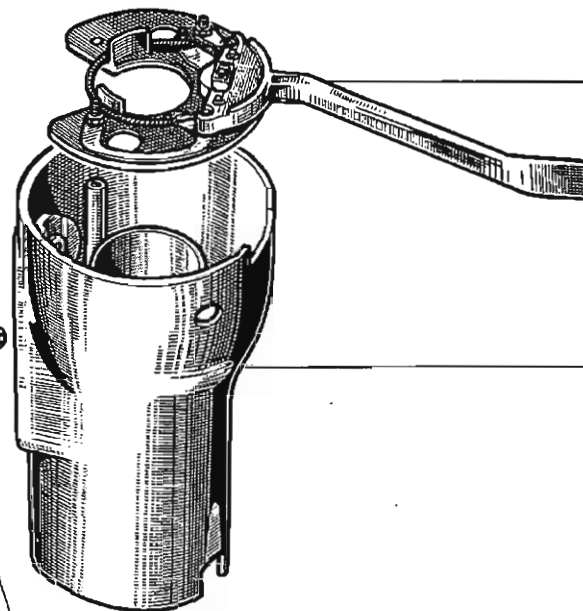
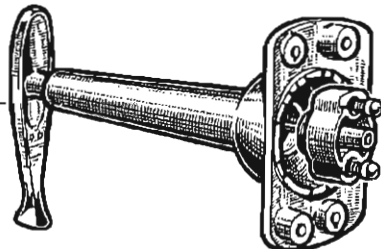

(2)

(3)

(4)

	8537502	8537506	8542629	8544229	8544353
(1)	8520756	8537528	8543002	8544796	8520756
(2)	8537503	8537503	8543004	8544797	8543004
(3)	8537504	8537504	8543001	8544795	8544795
(4)	8517812	8517812	8538935	8543814	8517812
(5)	8520757	8537529	8543003	8544798	8520757

XXXX
00000

32

08-00

	n°...	n°...		!!!
(a)	532893 VEH 880290 VEH	880289 ...	32	
(b) «DK» «AUS»	1-11-1959 VEH 836974 VEH		
(c) «D» «AS» «CH»	880290 VEH 894652 VEH		
(d)	532893 VEH	840299	32	
(e)	840300 VEH	...		



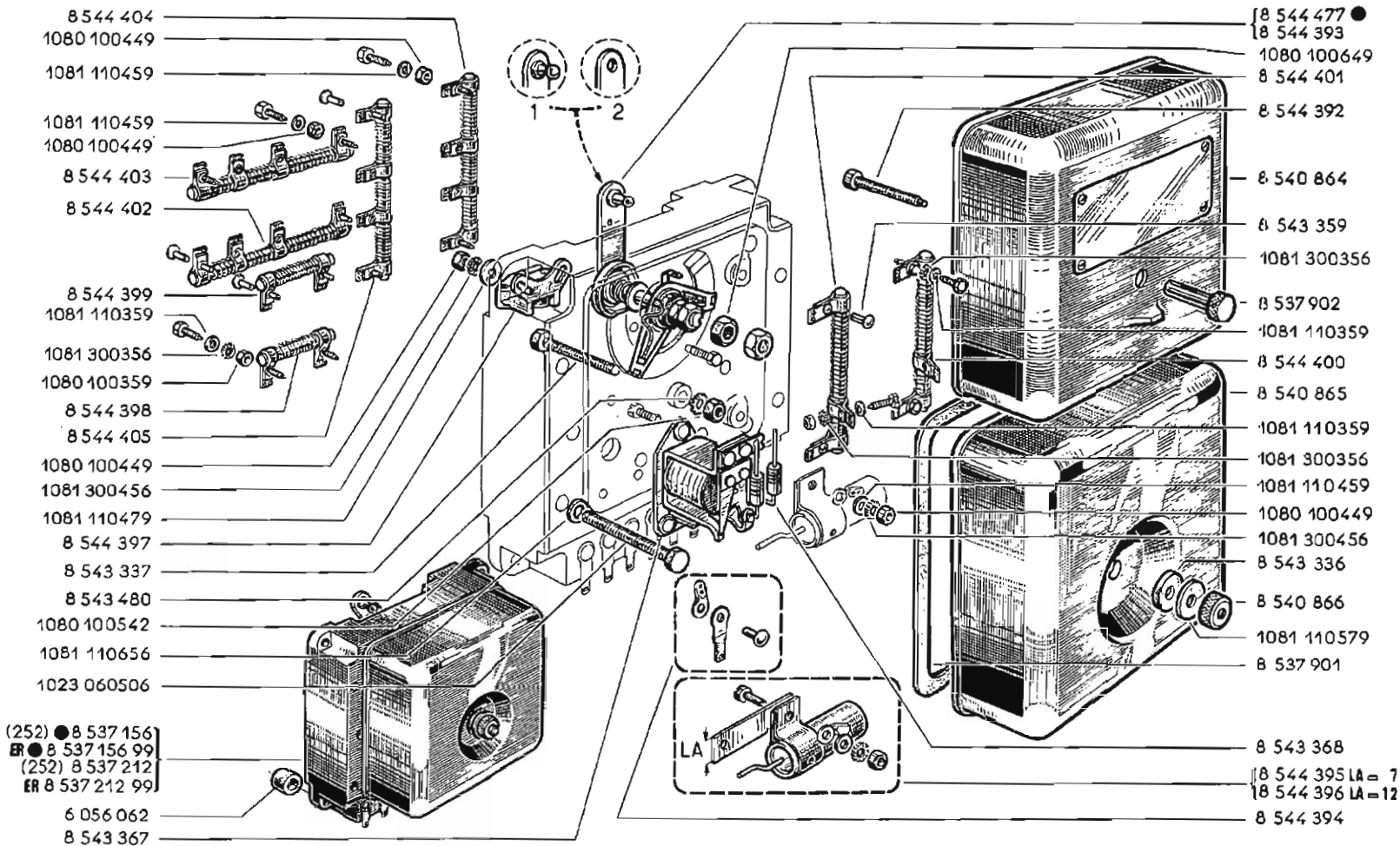

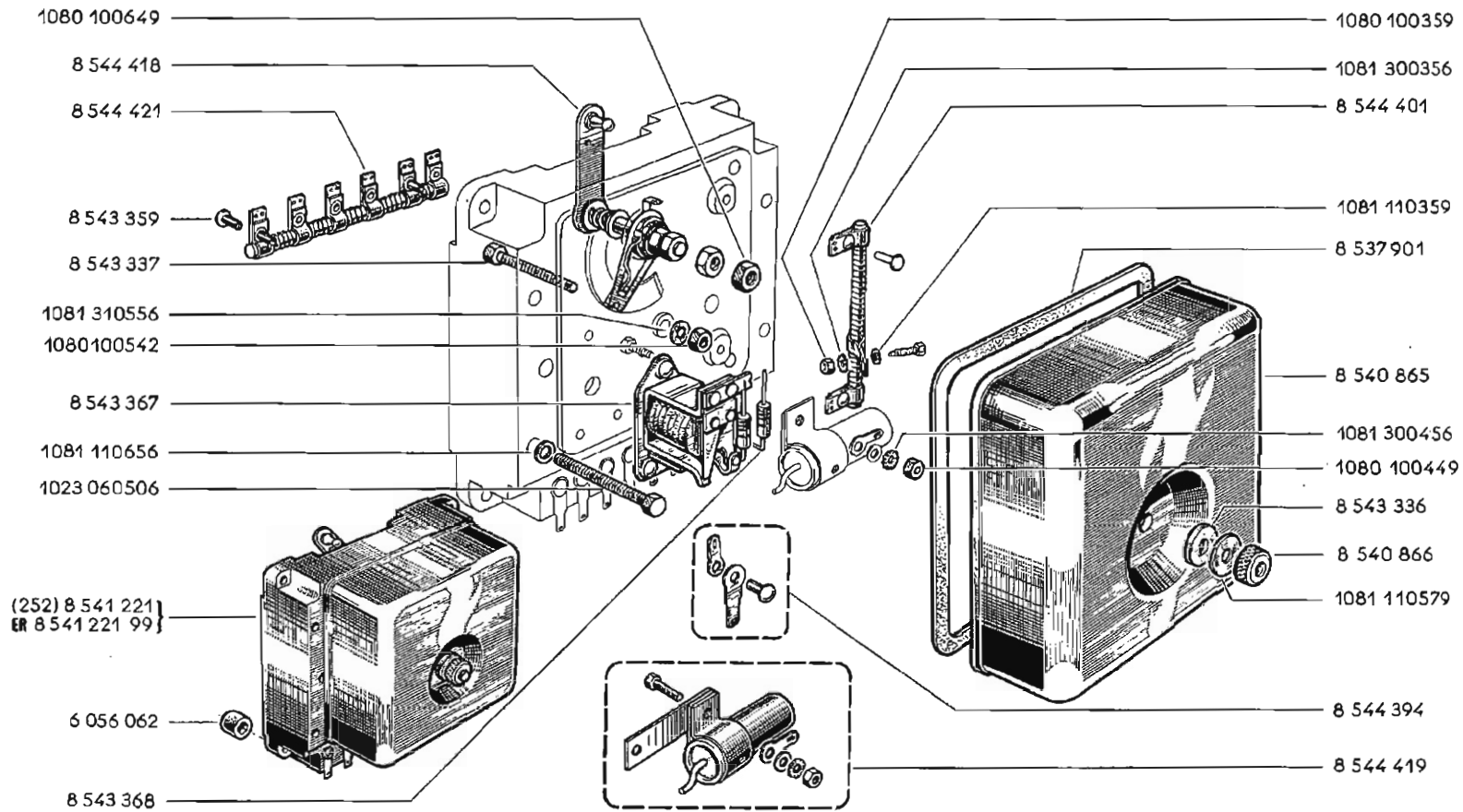

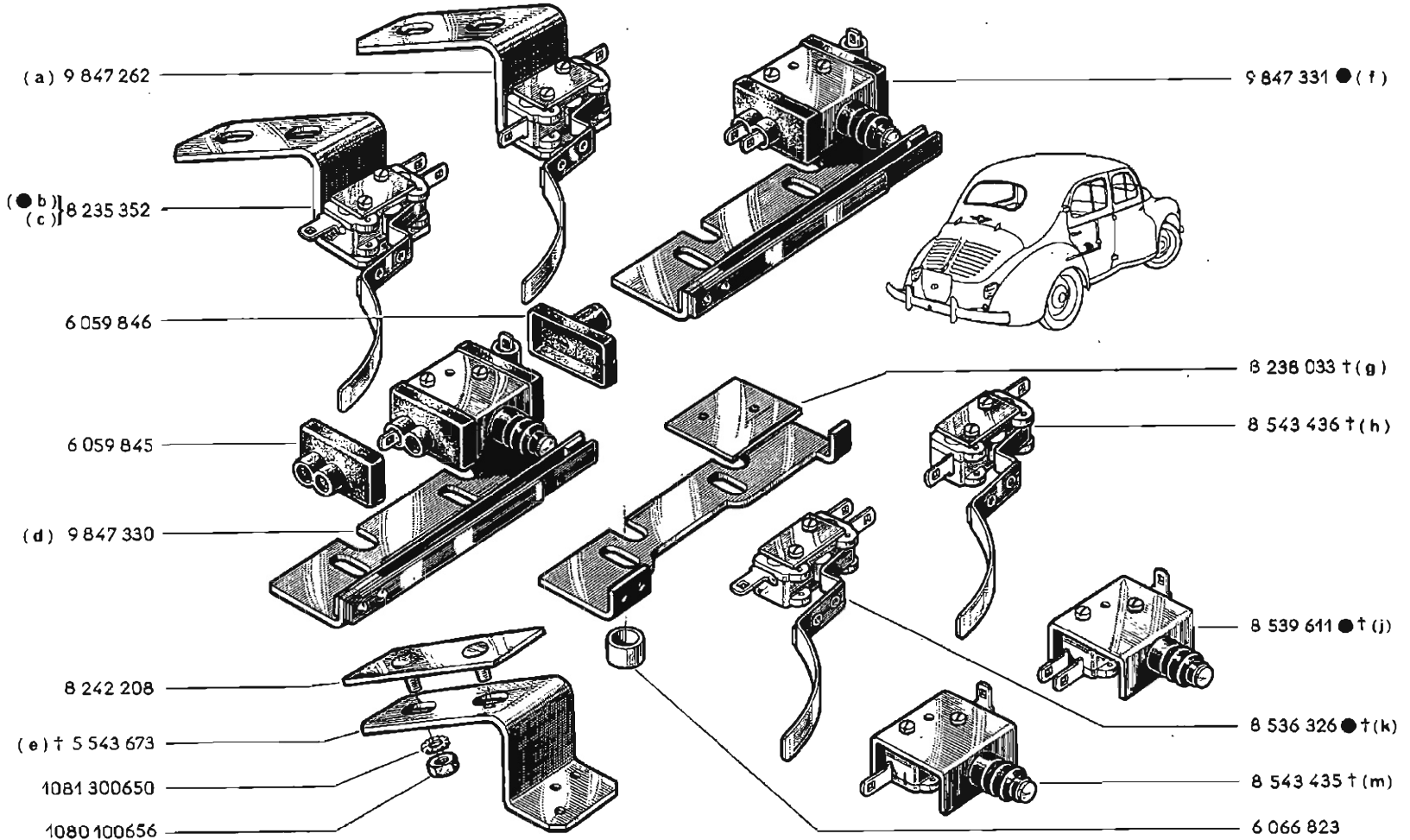

!!!

278	⊕	8235352 -1-
278		08-00
280	⊕	8847262
281		08-00
282	⊕	8847331 -1-
283		08-00
284	⊕	8847330 -1-
285		08-00
288		08-00
287	⊕	8847331 ● 8847330

	n°...	VEH	n°...	VEH	!!!
(a)	769953	VEH	841460	87	281
(b)	1	VEH	841460	87	278
(c)	1	VEH	769952		
(d)	841461	VEH	...	87	285
(e)	1	VEH	841460		288
(f)	841461	VEH	...	87	283
(g)	841461	VEH	...		287
(h)	769953	VEH	841460		280
(j)	841461	VEH	...		282
(k)	1	VEH	769952		278
(m)	841461	VEH	...		284

XXXX
DDDDD

87	08-00
----	------------------

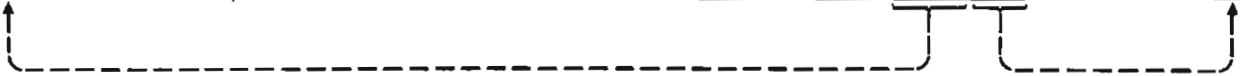

- (a) {
 - DEFA {
 - «CS» 9 803 904
 - «BB» † 9 836 233
 - «US» † 9 836 233
 - SEV 8 545 248
 - «CS» 9 836 534
 - † 9 836 423
 - 8 545 206

4 233 314 000

- (d) (R. 1060) (R. 2070) 743 617

- † 738 906
- † 8 526 964
- † 8 537 381
- 8 527 896

- (c) «US» 8 540 670

- 4 253 574
- 4 252 933

- MARCHAL {
- † 8 517 987
- † 8 517 988
- † 8 510 442

- 8 545 225
- AC 8 517 913
- KLG 8 537 756

RENAULT 9 803 004

- † 8 526 798
- † 8 526 797
- 8 527 895

LO=240 «CS» 9 504 455

LO=200 «CS» 9 504 454

- † 8 021 219
- † 8 510 611
- 6 048 072

(b) 1023 060166

(a) 1080 100656

1081 350656

1081 350656

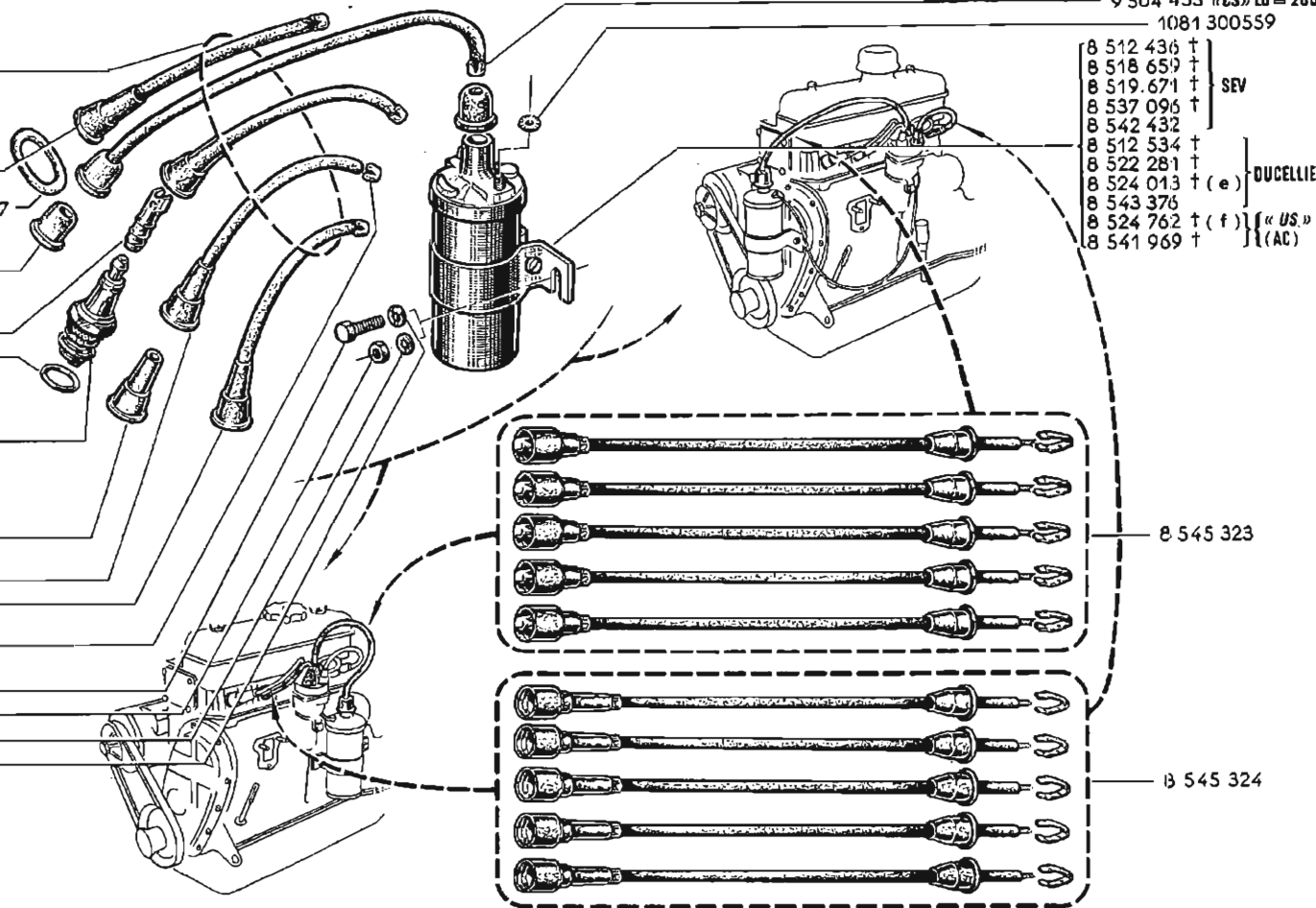

9 504 453 «CS» LO=280

1081 300559

8 512 436 †

8 518 659 †

8 519 671 †

8 537 096 †

8 542 432

8 512 534 †

8 522 281 †

8 524 013 † (e)

8 543 376

8 524 762 † (f)

8 541 969 †

SEV

DUCELLIER

«US.»

(AC)

8 545 323





8 545 324



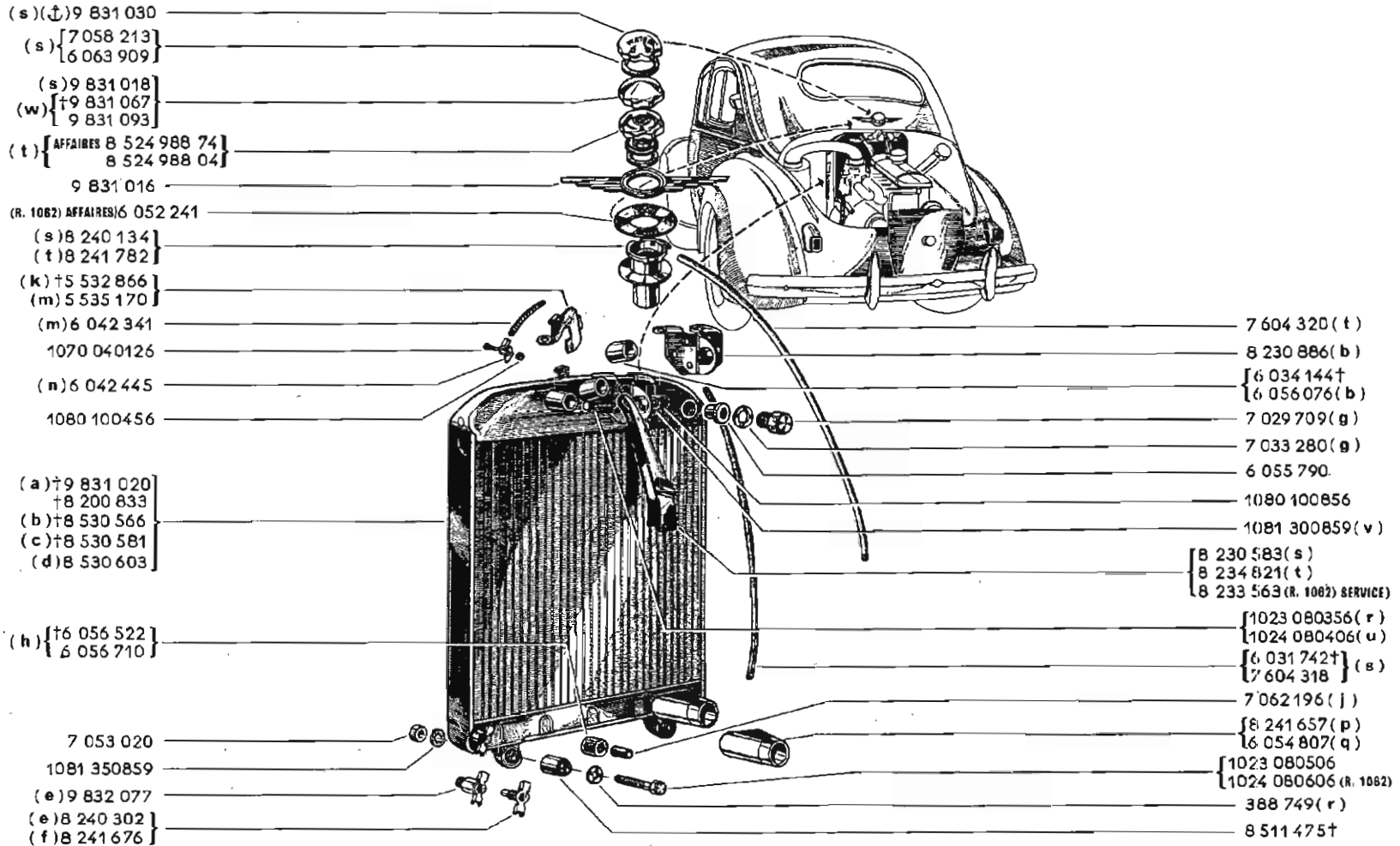

	n°...	→	n°...	✓	✗	!!!
(a)	1 VEH		869015			
(b)	869016 VEH		...			
(c)	721230 MOT		...			
(d)	1 MOT		1360			
(e)						78
(f)						199

!!!		
76	⊕	8537381 - 1 -
189	⊕	8540670 - 1 -





	n°...		n°...			
(a)						24
(b) R.1060 R.2070 R.2071 R.1082	1 VEH		734970			
(c) R.1060 R.2070 R.2071 R.1082 «CH» R.1082 «GR» R.1082 «P»						223 223 223 223 259 223 259 223 259
(d) R.1082						223 260
(e) R.1060 R.2070 R.1062 R.2071	1 VEH 1 VEH		310474 4240			
(f) R.1082 R.2071	310475 VEH 4241 VEH				
(g) R.1060 R.1062 SERVICE R.2070	1 VEH 1 VEH		6090 839			

		
24		6042341 -1- 6042445 -1-
223		8242810 -1- 1023 080188 -2- 1080 100656 -2-
259		 06-00
260		 06-00



	n°...	n°...		!!!
(h)				117
(j) R.1062	506295 VEH	...		
(k) R.1062	114736 VEH	...		
(m) R.1062	114736 VEH	734970		
R.2071	3589 VEH	...		
(n) R.1062	114736 VEH	172000		
R.2071	3589 VEH	4240		
(p) R.1060				
R.2070				
R.2071				
R.1082	1 VEH	631192		
(q) R.1062	631193 VEH	734970		
(r) R.1060				
R.2070				
R.2071				
R.1062	1 VEH	506294		
(s) R.1060				
R.2070				
R.2071				
R.1062	1 VEH	405209		
R.1062	405601 VEH	406426		
(t) R.1082	405210 VEH	405600		
R.1062	406427 VEH	...		
(u) R.1082	506295 VEH	...		
(v) R.1082	772484 VEH	...		
(w) R.1062 AFFAIRES	1 VEH	405209		
R.1062 AFFAIRES	405601 VEH	406426		

!!!

117		7082196 -1-
-----	--	-------------



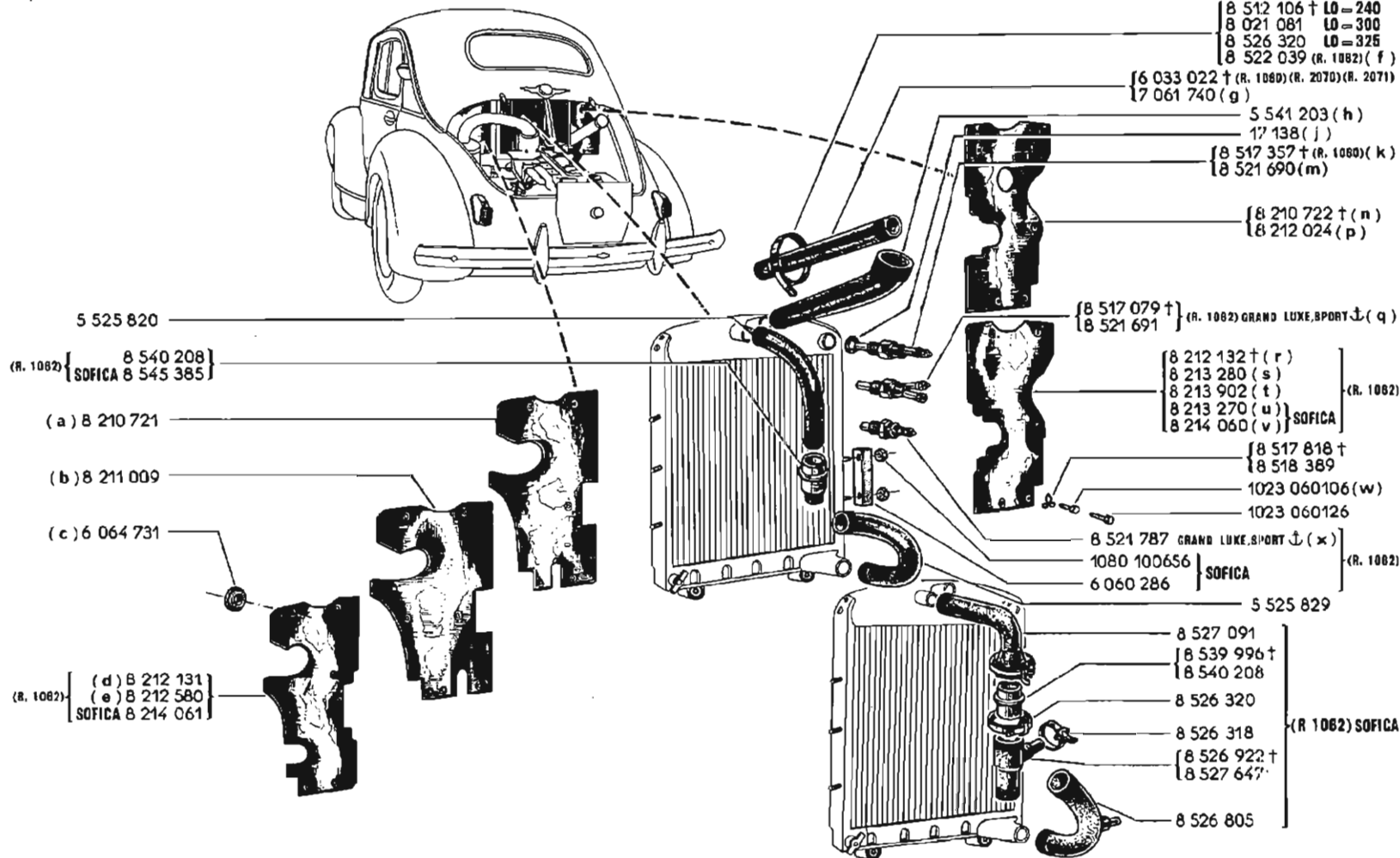

	n°...	n°...	!!!
(a) R.1060			
R.2070			
R.1062	1 VEH	69929	2 1
R.2071	1 VEH	2524	
(b) R.1062	69930 VEH	405209	1 2
R.1062	405601 VEH	406426	
R.2071	2525 VEH	...	
(c) R.1062	851458 VEH	...	
(d)	405210 VEH	405600	
	406427 VEH	532892	32
(e)	532893 VEH	...	32
(f)	419900 VEH	...	
(g) R.1060			
R.2070			
R.2071			
R.1062	1 VEH	405209	
R.1062	405601 VEH	406426	
(h) R.1062	405210 VEH	405600	
(j) R.1060	6091 VEH	...	
R.1062			
R.2071			
R.2070	840 VEH	...	
(k)	6091 VEH	...	
(m) R.1060	6091 VEH	...	
R.1062			
R.2070	1 VEH	840	
R.2071			
(n) R.1060			25
R.2070			25
R.2071			25
(p) R.1060			25
R.2070			25
R.2071			25
R.1062	1 VEH	405209	25
R.1062	405601 VEH	406426	25
(q)	5101 VEH	283715	
(r)	405210 VEH	405600	
	406427 VEH	703420	
(s)	405210 VEH	405600	
	406427 VEH	812763	
(t)	812764 VEH	...	
(u)	1 VEH	869015	
(v)	869016 VEH	...	
(w) R.1062	69930 VEH	...	1 2
R.2071	2525 VEH	...	
(x)	283716 VEH	...	

XXXX
00000

1	08-00
2	08-00
32	08-00

!!!

25	06-00
----	-------

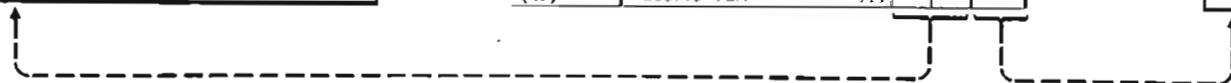

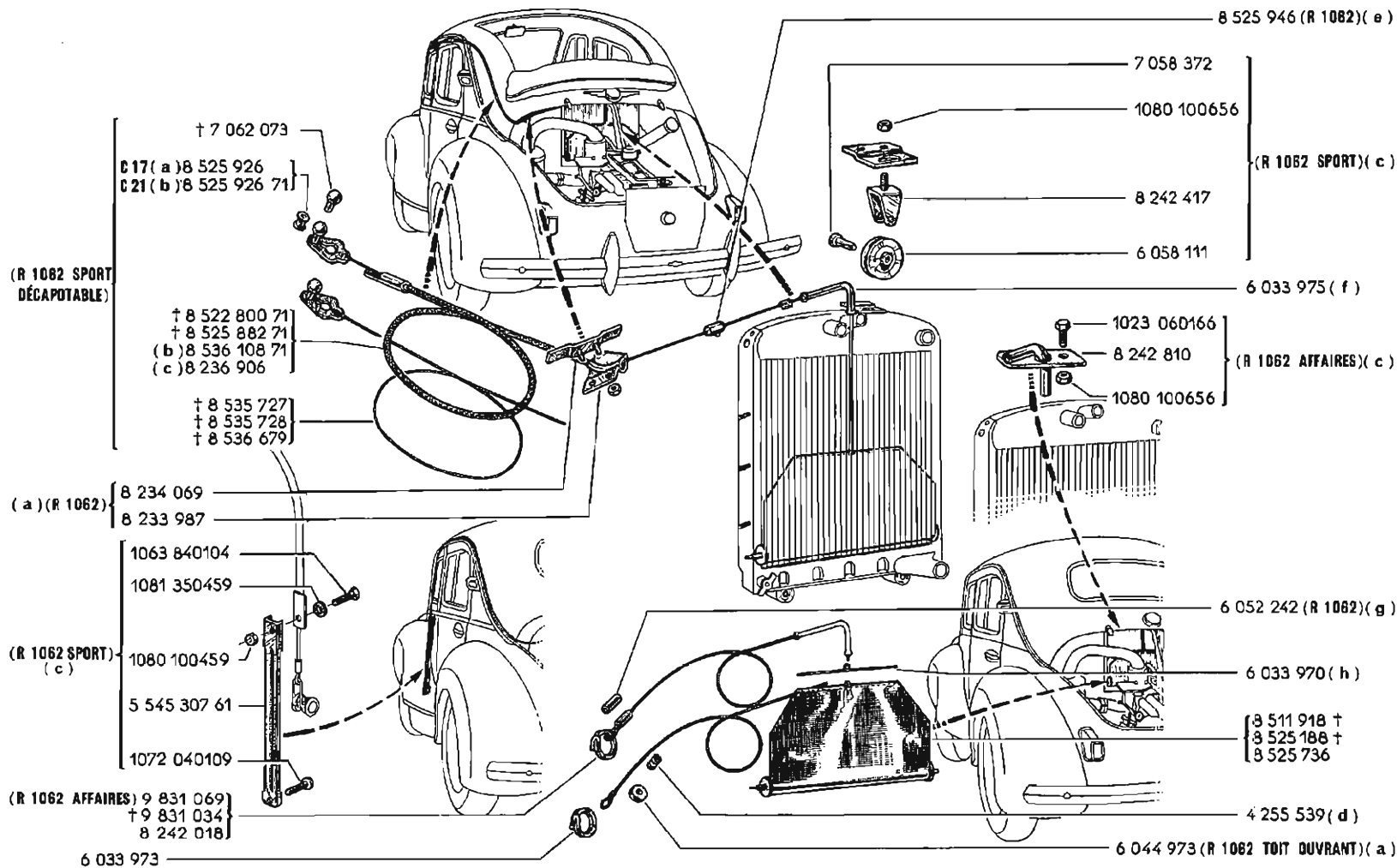



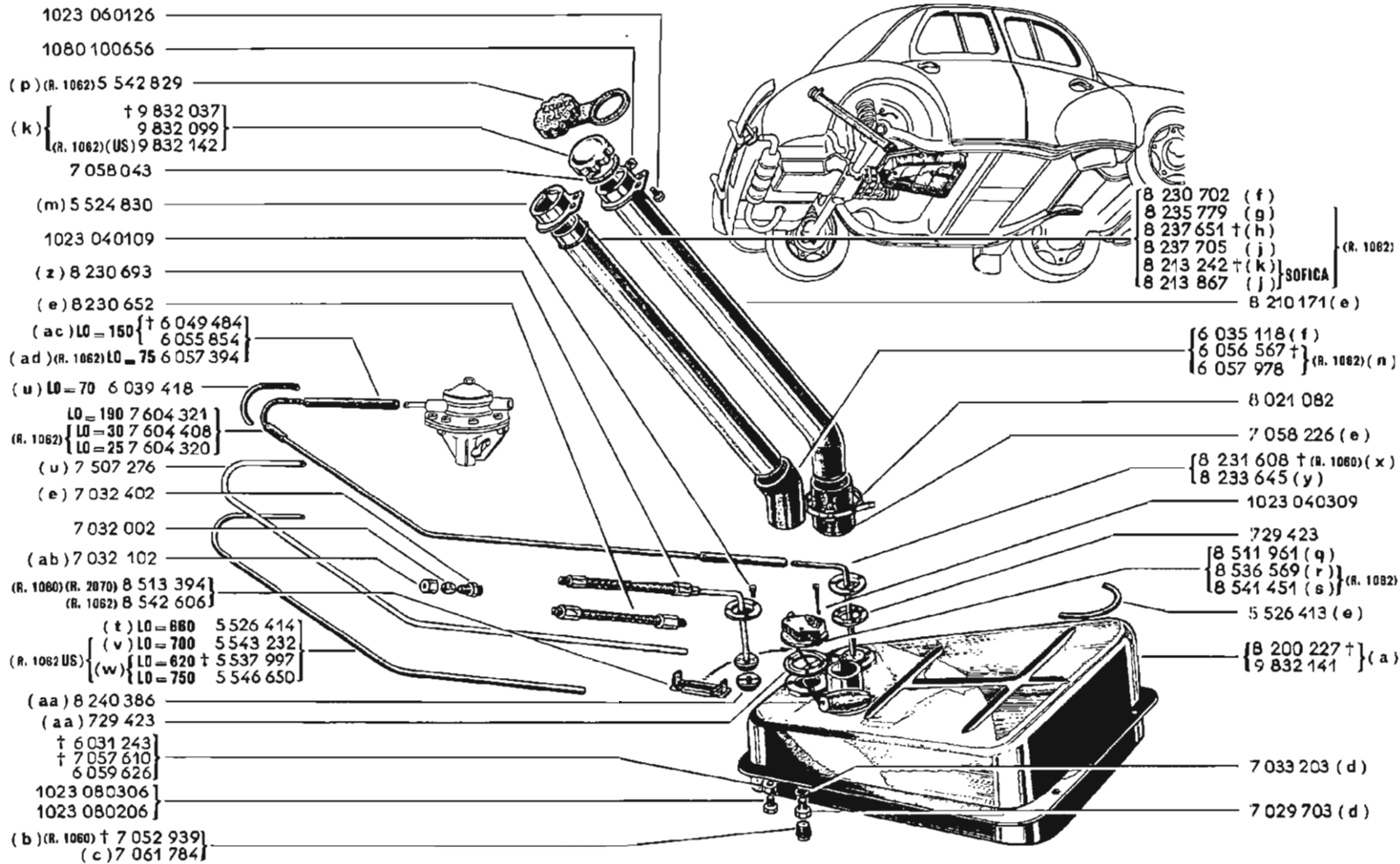

C17] 100-00
C21]

	n°...	⇨	n°...	↘	↙	!!!
(a)	283716 VEH		734970			
(b)	1 VEH		734970			
(c)	734971 VEH		...			
(d) R.1060						
R.2070						
R.1062	1 VEH		172000			
R.2071	1 VEH		4240			
(e)	283716 VEH		478559			
(f) R.1060						
R.2070						
R.1062	1 VEH		114735			
R.2071	1 VEH		3588			
(g)	460042 VEH		734970			
(h) R.1060						
R.2070						
R.1062	1 VEH		88992			
R.2071	1 VEH		2978			





	n°... 	n°... 	!!!
(a)			118
(b)	1473 VEH	3795	
(c) R.1060	1473 VEH	3795	
R.1062	10049 VEH	...	
R.2070	104 VEH	443	
R.2071	487 VEH	...	
(d) R.1060	3796 VEH	...	
R.1062	1 VEH	10048	
R.2070	444 VEH	...	
R.2071	1 VEH	486	
(e) R.1060	1 VEH	3795	
R.2070	1 VEH	443	
(f) R.1060	3796 VEH	...	
R.1062	1 VEH	572802	
R.2070	444 VEH	...	
R.2071			
(g)	572803 VEH	812763	
(h)	812764 VEH	833527	
(i)	833528 VEH	...	232
(k)	1 VEH	833527	
(m) R.1060			
R.2070			
R.2071			
R.1062	1 VEH	833527	
(n)	572803 VEH	...	
(p)	833528 VEH	...	
(q) R.1060			
R.2070			
R.2071			
R.1062	1 VEH	532892	32
(r)	532893 VEH	1-5-1958	32
(s)	1-6-1958 VEH	...	



32	
----	---

!!!

118	
232	



	n°...	n°...	!!!
(t) R.1060	1 VEH	107620	
R.1062 «US»			
R.1062	201403 VEH	...	88
R.2070	1 VEH	10029	
R.2071	4241 VEH	...	119
(u) R.1060	107621 VEH	...	
R.1062 «US»	1 VEH	203632	69
R.2070	10030 VEH	...	
R.2071	1 VEH	4240	
(v)	1 VEH	460887	
(w)	460888 VEH	...	
(x)	107621 VEH	...	
(y) R.1060	107621 VEH	...	
R.1062 «US»	324501 VEH	...	
R.1062			70
R.2070	10038 VEH	...	
R.2071			
(z) R.1060	3796 VEH	107620	
R.1062			70
R.1062 «US»	1 VEH	324500	
R.2070	444 VEH	10029	
(aa) R.1060	3796 VEH	...	
R.1062			
R.2071			
R.2070	444 VEH	...	
(ab) R.1060	1 VEH	3795	
R.1062 «US»	1 VEH	324500	
R.1062	203633 VEH	...	68
R.2070	1 VEH	443	
R.2071	4241 VEH	...	
(ac) R.1062 «US»	1 VEH	654533	
R.1062 «US»	654801 VEH	655676	
R.1062	224887 VEH	225000	
R.1062	225569 VEH	...	
R.2071	4240 VEH	...	
(ad)	654534 VEH	654800	
	855677 VEH	...	

	XXXX 00000
68	08-00
69	08-00
70	08-00

	!!!
119	06-00



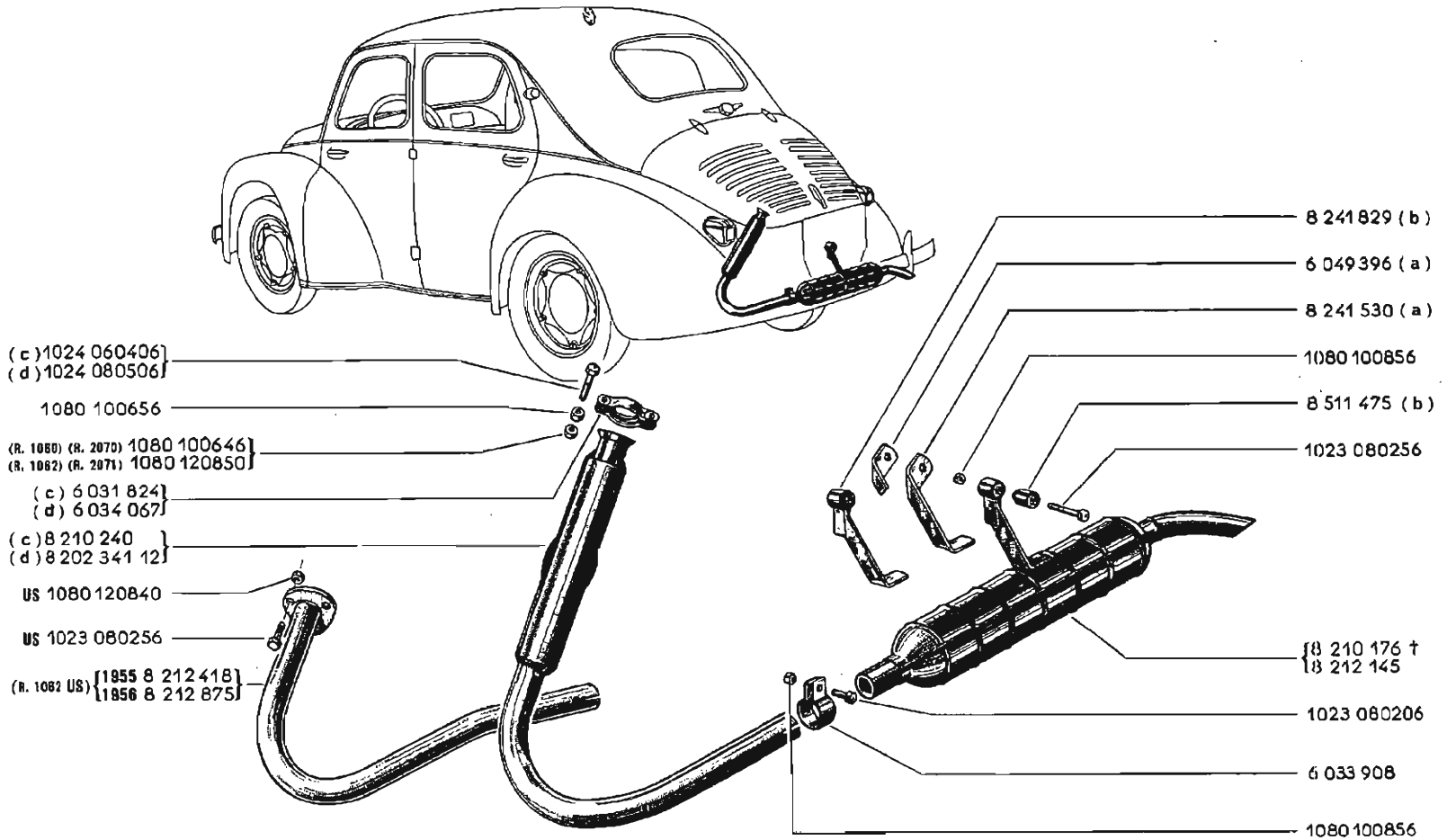



	n°...	n°...	!!!
(a) R.1080			
R.2070			
R.1062	1 VEH	414899	68
R.2071	1 VEH	4240	
(b) R.1082	414900 VEH	...	68
R.2071	4241 VEH	...	
(c) R.1080			
R.2070			
R.1062	1 MOT	521144	
R.2071			
(d) R.1082	521145 MOT	...	
R.2071			
R.1082 «US»	872576 MOT	...	



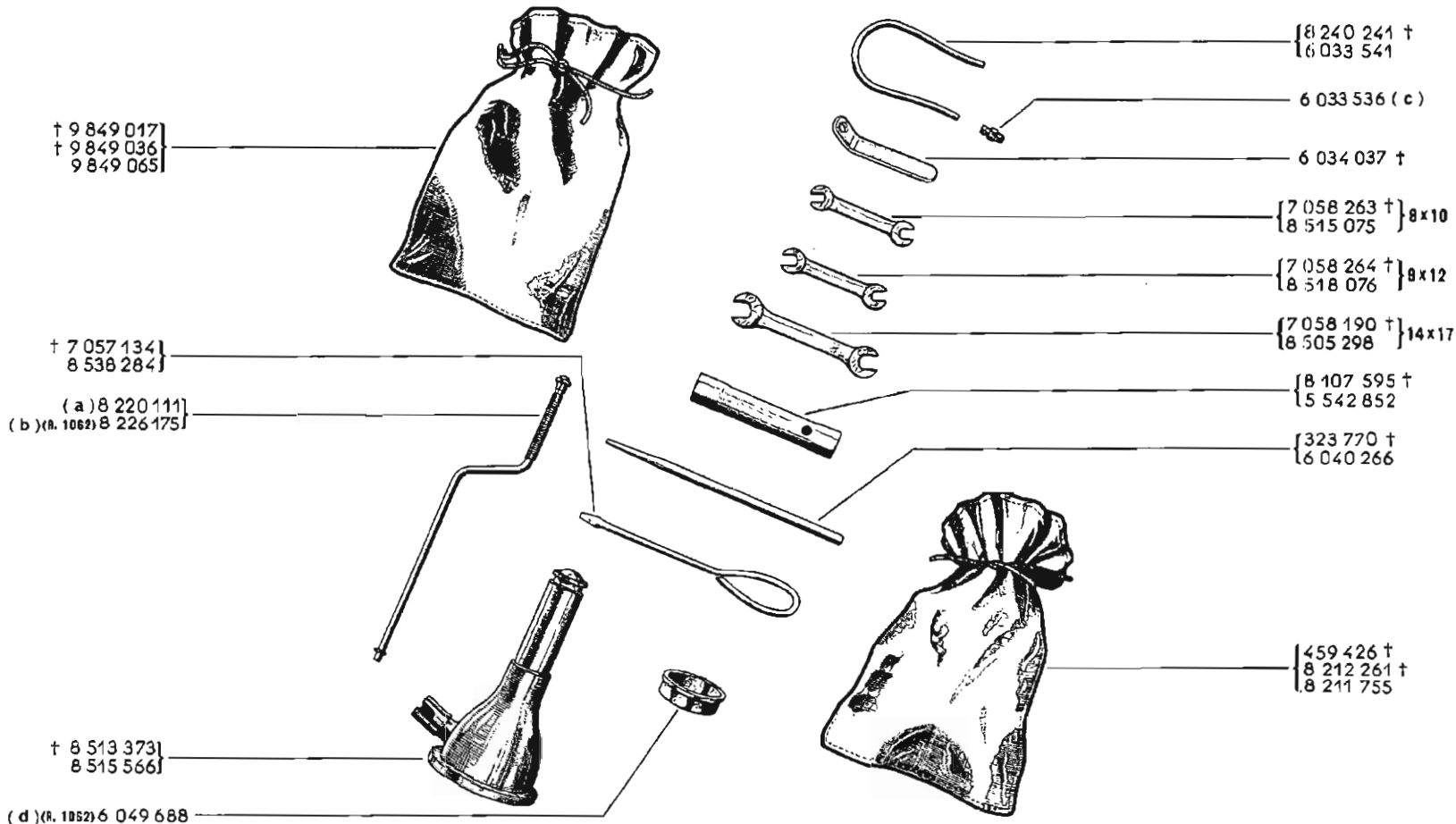

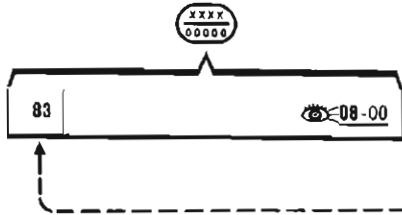

	n°...	n°...	!!!
(a) R.1080 R.2070 R.2071 R.1062	1 VEH	748117	83
(b)	748118 VEH	...	83
(c) R.1080 R.2070 R.1062 R.2071	1 VEH 1 VEH	81349 2799	
(d)	1 VEH 405601 VEH	405209 406426	

- (R. 1082) (g) 9 991 062 17
- (b) † 9 930 302 17
- (h) † 9 990 389 17
- (d) † 9 990 724
- (e) 9 990 762
- (f) 9 991 198
- (q) 9 991 065 17
- (r) † 9 990 306 17
- (s) † 9 990 390
- (t) † 9 990 725
- (j) 9 990 763

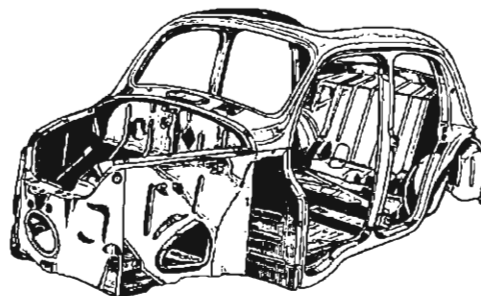
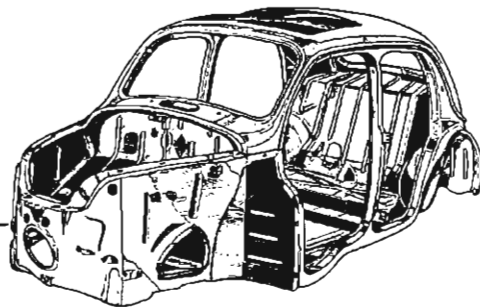

- 9 991 063 17 (g)
- 9 990 301 17 † (b)
- 9 990 385 17 † (h) (R. 1082)
- 9 990 726 (d)
- 9 990 764 (j)
- 9 991 066 17 (u)
- 9 990 305 17 † (r)
- 9 990 386 17 † (s) (R. 1082)
- 9 990 727 † (t)
- 9 990 765 (i)

- (R. 1082) (a) † 9 990 027 17
- (b) † 9 990 300 17
- (c) † 9 990 387 17
- (d) † 9 990 722
- (e) 9 990 760
- (f) 9 991 197
- (k) 9 990 026 17
- (m) † 9 990 304 17
- (n) † 9 990 388 17
- (p) † 9 990 723
- (j) 9 990 761

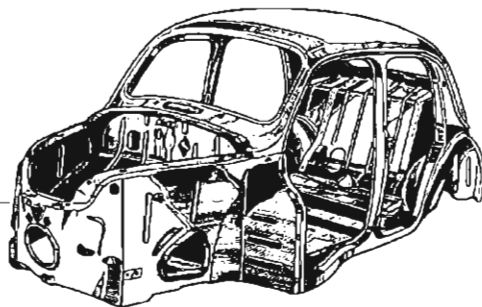

	n°...	n°...			!!!
(m)	69930 VEH	484678	1	2	120 122 128
(n)	69930 VEH	...	1 29	2	120 122 128 187
(p)	69930 VEH	729263	1 28	2	120 122 128 197 213
(q) R.1060 R.1062	1 VEH	69929	2	1	120 128
(r)	69930 VEH	484678	1	2 29	120 122 124 128 197
(s)	69930 VEH	...	1 29	2	120 122 124 128 197
(t)	69930 VEH	729263	1 28	2	120 122 124 128 197 213
(u) R.1080 R.1082	1 VEH	69929	2	1	124 128

XXXX 00000	
1	08-00
2	08-00
29	08-00

!!!	
120	8240376 -1-2- 6033625 -1-2-
122	8241413 -1- 9980669 -1- 9980722 -1- 9980668 -1- 9980670 -1- 9830736 -1- 9830737 -1- 9830738 -1- 8521787 -1- 5537609 -1-
124	6055188 -1- 6038168 -1- 8038168 -1- 6048318 -1-
128	6039518 -1- 6039517 -1- 8231589 -1-
197	8224857 -1- 8235373 -1- 8242208 -1-
213	8527101 -1-



	n°...	n°...	XXX 0000	!!!
(a) R.1060 R.1062 R.2070 R.2071	1 VEH	69929	2	1 121 123
(b)	69930 VEH	484678	1	2 120 29 122 123 128
(c)	69930 VEH	703420	1 29	2 120 122 123 128 197
(d)	69930 VEH	729263	1 29	2 120 122 123 128 197 213
(e)	729264 VEH «CH» 1 VEH	... 894651		
(f) «US» «D» «A» «CH»	840300 VEH 880290 VEH 880290 VEH 894652 VEH	880289		
(g) R.1060 R.1082	1 VEH	69929	2	1 121 123 128
(h)	69930 VEH	...	1 29	2 120 122 123 128 197
(j)	729264 VEH	...		
(k) R.1060 R.1082 R.2070 R.2071	1 VEH	69929	2	1 120 121 128

	XXX 0000
1	08-00
2	08-00
29	08-00

	!!!
120	8240376 -1-2- 8033825 -1-2-
121	8240484 -2-
122	8241413 -1- 9880689 -1- 9880722 -1- 9880868 -1- 9880870 -1- 9830736 -1- 9830737 -1- 9830738 -1- 8521787 -1- 5537808 -1-
123	8055768 -1- 8038187 -1- 8038188 -1- 8048318 -1-
128	8038518 -1- 8038517 -1- 8231508 -1-
187	8224847 -1- 8235373 -1- 8242208 -1-
213	8527101 -1-

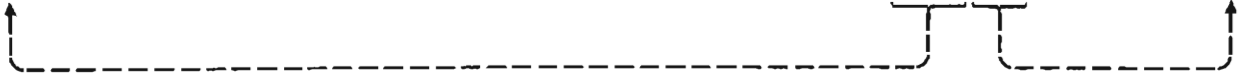

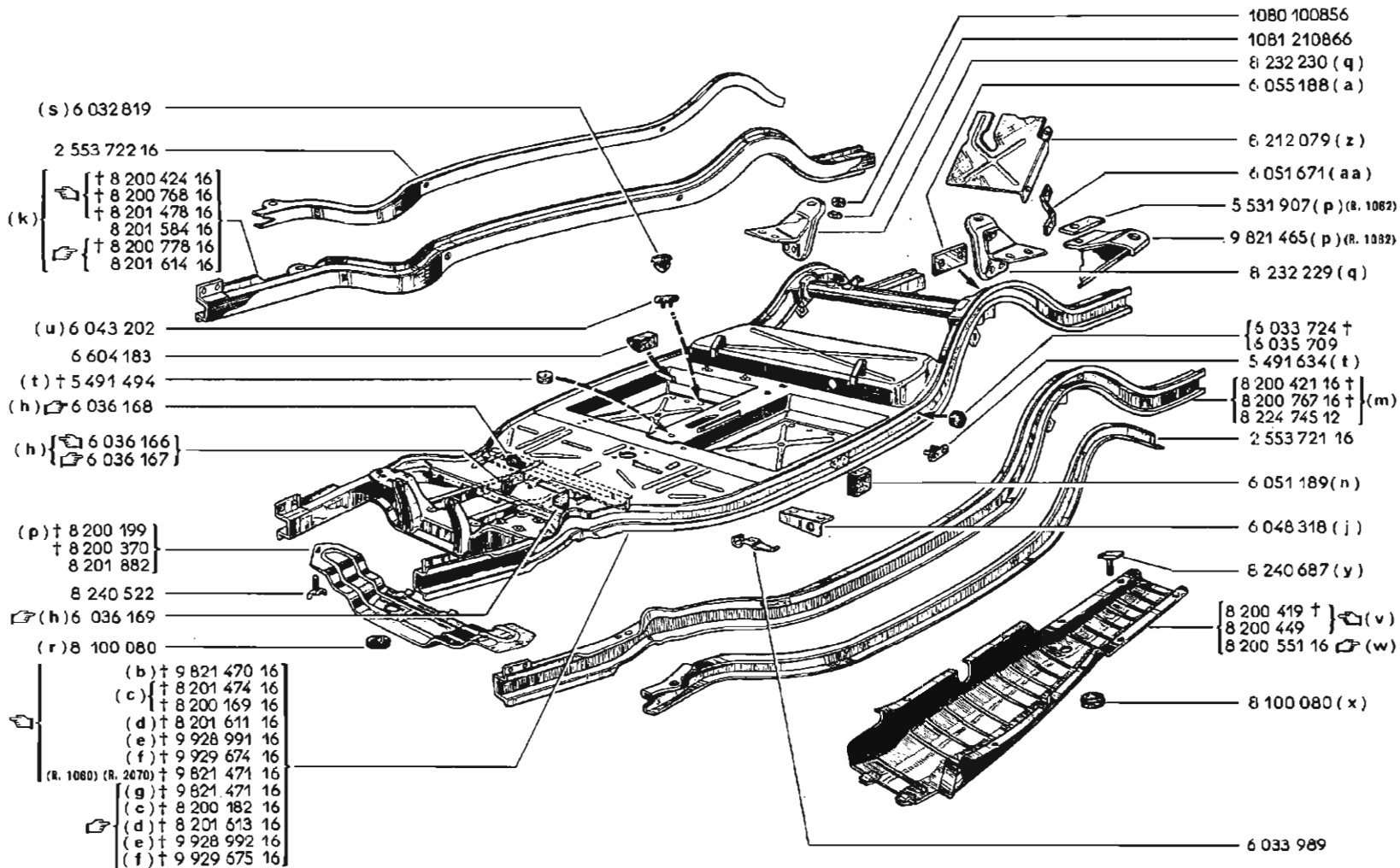

	n°...	n°...	!!!
(r) R.1060 R.1062 R.2071 R.2070	8301 VEH 1211 VEH	...	
(s) R.1060 R.1062 R.2070 R.2071	401 VEH 1 VEH 1 VEH	63243 2353	
(t) R.1060	127001 VEH	...	
(u) R.1060 R.1062 R.2070 R.2071	127001 VEH 1 VEH	...	
(v)			15
(w) R.1060 R.1062 R.2071 R.2070	125102 VEH 81 VEH	...	
(x) R.1060 R.2070	90605 VEH 9543 VEH	110222 ...	15 82
(y) R.1060 R.1062 R.2070 R.2071	90605 VEH 9543 VEH	...	15 82
(z) R.1062	371928 VEH	...	
(aa) R.1062	371928 VEH	622970	

XXXX
00000

15	08-00
82	08-00



81.07

A P.R. 685

{ (R. 1080) (R. 2070)† 6 036 133
(d) 4 266 827
(c) 3 534 165 }

{ (a) 6 034 394
(b) 4 266 450
(c) 3 534 166
FERLEC 3 534 956 }

{ (R. 1080) (R. 2070)† 6 036 133
(d) 4 266 826
(c) 3 534 164 }

{ (a) 6 034 393
(b) 4 266 449
(c) 3 534 163
FERLEC 3 534 957 }

{ (R. 1080) (R. 2070) (R. 2071) 6 042 662
(R. 1082 NORMAL) }
(R. 1082) 6 058 291

5 526 627

5 526 626

(w) 6 052 121

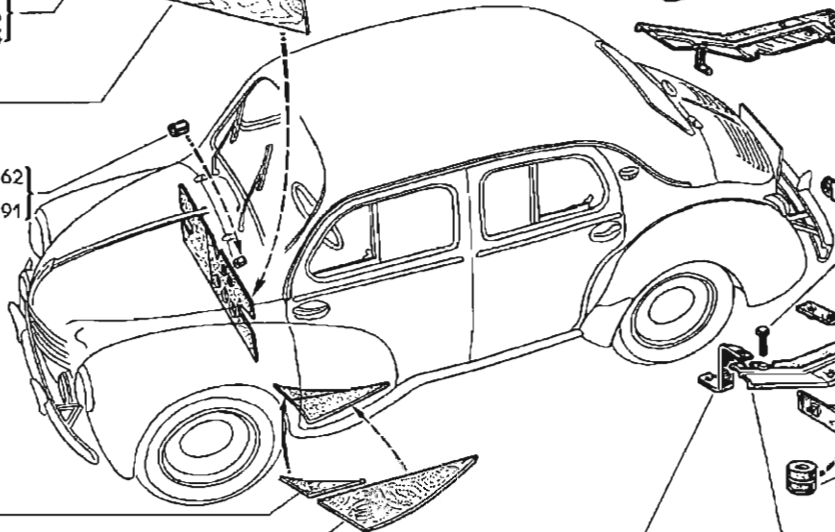
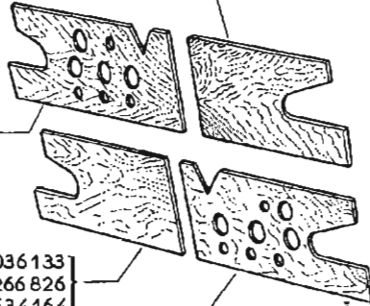

81.07

A P.R. 685

{ 7 604 357†
7 604 132 } VAM

8 200 196 (e)

8 201 446 (f)

8 201 448 (f)

{ 8 220 456 (e)
8 201 444 (f)
8 234 584 (R. 1082) FERLEC }

6 035 389 (x)

8 510 909

5 527 449 (y)

{ 1023 060166
1023 060106 (R. 1082) (R. 2071) }

6 052 123 (w)

8 200 195 (g)

8 200 859 (h)

8 201 645 (i)

8 224 127† (k)

8 212 481 (p)

8 200 945 (m)

8 201 815 (j)

8 224 129† (n) US

8 212 626† (n)

8 213 635 (p)

6 065 222 (u)

{ 1081 300656
1081 350656 (R. 1082) }

6 035 709 (z)

6 041 385 (v)

{ 8 220 445† } (q)

3 533 917† (q)

8 212 672 (r)

8 212 671 (s)

5 542 287 (t)

{ 5 544 103 (s) } FERLEC

XXXX
00000

1	08-00
2	08-00
25	08-00
26	08-00
29	08-00
34	08-00

XXXX
00000

!!!

	n°...	n°...		
(a) R.1080				
R.2070				
R.1082	1 VEH	37000		
R.2071	1 VEH	1600		
(b) R.1082	37001 VEH	484678		29
R.2071	1601 VEH	...		
(c) R.1082	484679 VEH	...	29	
(d) R.1080				
R.2070				
R.1082	69930 VEH	484678	1	34
R.2071	2525 VEH	...		2
(e) R.1080				
R.2070				
R.2071				
R.1082	1 VEH	283715		
(f) R.1082	283716 VEH	...		
(g) R.1080				
R.2070				
R.1082	1 VEH	69929	2	1
R.2071	1 VEH	2524		
(h) R.1082	69930 VEH	283715	1	2
R.2071	2525 VEH	...		
(j) R.1082	283716 VEH	450603	26	25

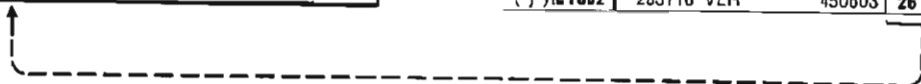

	n°...		n°...	25	26	!!!
(k) R.1062	450604 VEH		516152			
(m) R.1062	69930 VEH		283715			
(n) R.1062	450604 VEH		532892			
(p) R.1062	450604 VEH		...			
(q) R.1060						129
R.2070						129
R.2071						129
(r) R.1060						129
R.2070						129
R.2071						129
R.1062	1 VEH		532892	32		129
(s) R.1062	532893 VEH		...	32		129
(t) R.1062	1 VEH		532892	32		129
(u) R.1062	839642 VEH		...			
(v) R.1060						
R.2070						
R.2071						
R.1062	1 VEH		450603	25	25	
(w) R.1062	450604 VEH		...	25	26	
(x) R.1060	1 VEH		114657			
R.1060	114660 VEH		118230			
R.2070	1 VEH		10316			
(y) R.1060	36669 VEH		...			
R.1062						
R.2071						
R.2070	4652 VEH		...			
(z) R.1062	615907 VEH		...			

YXXX
00000

25	08-00
26	08-00
32	08-00

!!!

129	06-00
-----	-------

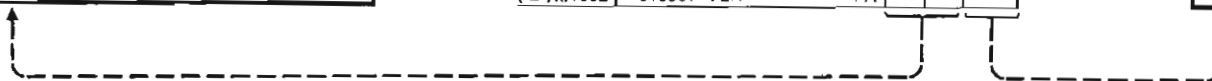

81.09

A P.R. 685

- † 5 528 192
- (u) 5 543 035
- (p) 6 051 425
- (q) 5 525 646
- † 6 044 596
- 6 061 154
- (q) 5 525 645
- (t) 6 050 741
- † 8 210 194 16
- † 8 210 669 16
- 8 211 547 16
- (q) 8 210 611 16
- (s) † 8 211 701 16
- 9 928 942 16
- (R 1062 SERVICE) 8 211 541 16

- (a) † 2 554 048 16
- † 8 200 176 16
- † 8 201 832 16
- † 8 221 298 16
- (b) † 8 202 178 16
- (a) † 8 203 326 16
- 8 202 178 16

- † 8 200 171 16
- † 8 201 435 16
- † 8 201 642 16
- † 8 201 653 16
- 8 202 070 16

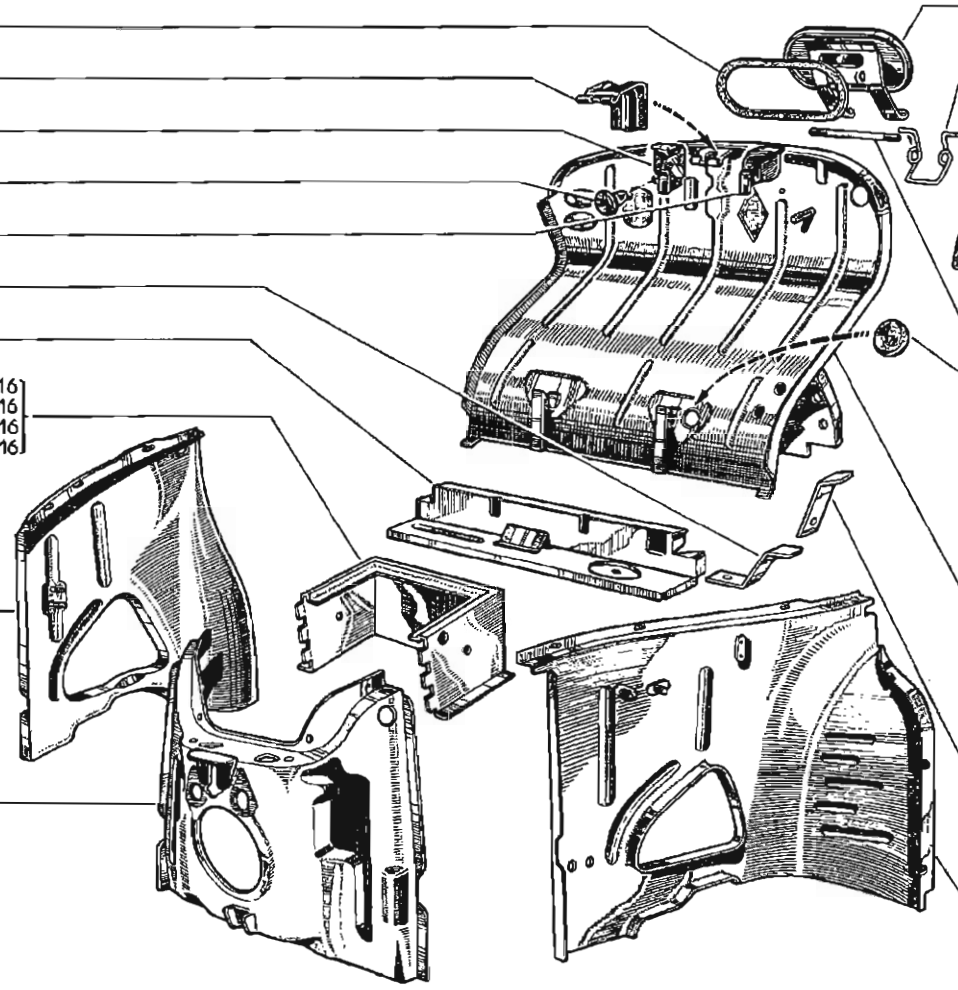

81.09

A P.R. 685

- 8 230 210 (u)
- 6 033 816 (z)
- 8 231 153 † (aa)
- 8 234 589 † (ab)
- 8 235 243 (aa)
- 8 235 439 (ac)
- 6 032 021 †
- 6 040 514
- 6 035 405 (z)
- 6 031 404
- 8 515 189 79 (x) C17
- 8 515 189 71 (p) C21
- 8 538 575 (y) C18
- 6 039 274 † (v)
- 6 040 515 (v)
- 6 055 949 (w)
- 6 032 018 (z)
- 5 478 616 (r)



- 9 928 774 16 † (c)
- 9 920 026 16 † (c)
- 9 920 050 16 † (d)
- 9 920 057 16 † (c)
- 9 920 084 16 † (e)
- 9 920 125 (e)
- 9 920 091 † (f)
- 9 920 127 (g)
- 9 929 310 16 † (h)
- 9 920 129 (g)
- 9 920 084 16 † (f)
- 9 920 130 (j)
- 9 920 027 16 † ((R 1060, R. 2070, R. 2071))
- 9 920 051 16 † (k)
- 9 920 058 16 † (k)
- 9 920 085 † (m)
- 9 920 092 † (n)
- 9 920 126 (g)
- 9 920 092 † (g)
- 9 920 128 † ((R 1062 FERLEC))

6 050 743 (t)



- 8 200 163 16 †
- 8 201 641 16 † (a)
- 8 223 581 16 †
- 8 233 943 16 †
- 8 202 177 16 † (b)
- 8 233 551 16 † ((R 1062))
- 8 202 181 16 † (SERVICE (a))
- 8 203 325 16 (a)
- 8 202 177 16



C17
C21
C18

100-00

29	 08-00
32	 08-00
83	 08-00

XXXX
00000

	n°...		n°...		
(a)					132
(b) R.1060					132
R.2070					132
R.2071					132
R.1062	1 VEH		734970		132
(c) R.1060					133
R.2070					133
R.2071					133
(d) R.1060					133
R.2070					133
R.2071					133
R.1062	1 VEH		484678	29	133
(e)					133
(f) R.1062	1 VEH		748117	83	133
(g) R.1062					133
(h) R.1060					133
R.1062	1 VEH		748117		133
(j) R.1062	748118 VEH		...	83	
(k) R.1060					
R.2070					
R.2071					
R.1062	1 VEH		484678	29	133
(m) R.1060					133
R.2070					133
R.2071					133
R.1062	1 VEH		748117	29 32	133
(n) R.1062	532893 VEH		748117	32 83	
(p) R.1062	405210 VEH		405600		
R.1062	406427 VEH		...		

132		5526101 -2-
133		5525645 -1- 5525646 -1- 8240464 -2-

!!!



	n°...	n°...	!!!
(q) R.1060 R.2070 R.2071 R.1062	1 VEH	283715	
(r) R.1060 R.2070 R.2071 R.1062	1 VEH	484678	28
(s) R.1062	283716 VEH	...	134
(t) R.1062	335626 VEH	...	75
(u) R.1060 R.2070 R.2071 R.1062	729263 VEH	...	
(v) R.1060 GD LUXE R.1062 SPORT	1 VEH	532892	32
(w) R.1062 SPORT	532893 VEH	729263	32
(x) R.1060 GD LUXE R.1062 SPORT R.1062 SPORT	1 VEH 405601 VEH	405209 406426	
(y) R.1062 SPORT R.1062 SPORT	405210 VEH 406427 VEH	405600 729263	
(z) R.1060 R.2070 R.2071 R.1062	1 VEH	729263	
(aa) R.1060 R.1062 R.2070 R.2071	69628 VEH 1 VEH 8464 VEH	... 532892 ...	32
(ab) R.1062	1 VEH	532892	
(ac) R.1062	532893 VEH	...	32

XXXX
00000

29	08-00
32	08-00
75	08-00

!!!

134	8212220 -1- 5541667 -2- 5541870 -1-
-----	---



81.11

A P.R. 685

- †9 906 423 16]
- 2 553 996 16]
- (R. 1060)(R. 1082)†2 554 122 16]
- 2 554 468 16]
- †9 906 478 16]
- 9 907 177 16]
- 2 553 976 16]
- (a)†9 906 328 16]
- (b)†9 906 935 16]
- †9 907 066 16]
- (c)†9 907 130 16]
- (d)†9 907 348
- (e)9 907 365
- (f)9 907 399
- 2 554 123 16]
- 2 554 125 16]
- †8 201 464 16]
- †8 200 154 16]
- 8 201 784 16]
- 2 554 158 16]
- (k)3 528 318 16]
- (m)†3 533 878 16]
- (n)9 929 804]
- (p)†8 210 274 16]
- 8 210 232 16]
- (q)†3 528 312 16]
- 8 210 231 16]
- 8 210 232 16]
- (ab)8 200 769]
- (ac)8 223 948 16]
- (R. 1082)7 058 091
- 9 906 990 16]
- (R. 1060)(R. 1082)†2 554 121 16]
- 2 554 467 16]
- (aa)6 046 415
- (aa)8 220 330 16]
- 2 554 157 16]
- (p)8 210 273 16]
- 8 210 231 16]
- (k)3 528 317 16]
- (m)†3 533 887 16]
- (n)9 929 803]
- †8 201 465 16]
- †8 200 153 16]
- 8 201 783 16]

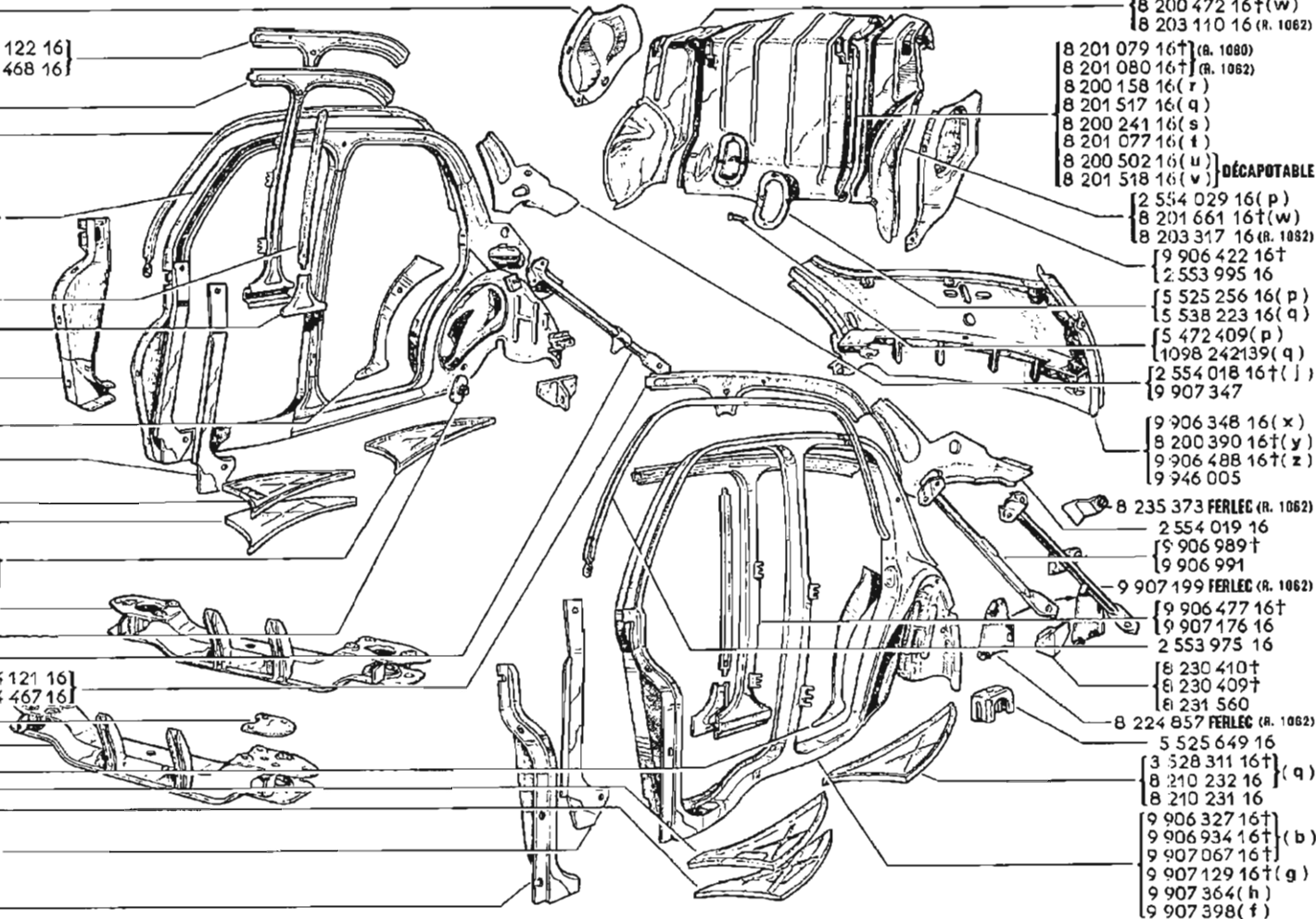

81.11

A P.R. 685

- [2 554 030 16(p)
- [8 200 472 16†(w)
- [8 203 110 16 (R. 1082)
- 8 201 079 16†](R. 1080)
- 8 201 080 16†](R. 1082)
- 8 200 158 16 (r)
- 8 201 517 16 (q)
- 8 200 241 16 (s)
- 8 201 077 16 (t)
- 8 200 502 16 (u)
- 8 201 518 16 (v) DÉCAPOTABLE
- [2 554 029 16 (p)
- [8 201 661 16†(w)
- [8 203 317 16 (R. 1082)
- [9 906 422 16†
- [2 553 995 16
- [5 525 256 16 (p)
- [5 538 223 16 (q)
- [5 472 409 (p)
- [1098 242139 (q)
- [2 554 018 16†(j)
- [9 907 347
- [9 906 348 16 (x)
- [8 200 390 16†(y)
- [9 906 488 16†(z)
- [9 946 005
- 8 235 373 FERLEC (R. 1082)
- 2 554 019 16
- [9 906 989†
- [9 906 991
- 9 907 199 FERLEC (R. 1082)
- [9 906 477 16†
- [9 907 176 16
- 2 553 975 16
- [8 230 410†
- [8 230 409†
- [8 231 560
- 8 224 857 FERLEC (R. 1082)
- 5 525 649 16
- [3 528 311 16†](q)
- [8 210 232 16
- [8 210 231 16
- [9 906 327 16†
- [9 906 934 16†](b)
- [9 907 067 16†
- [9 907 129 16†(g)
- [9 907 364 (h)
- [9 907 398 (f)

	n°...	n°...	!!!
(a) R.1060			135
R.2070			135
R.2071			135
(b)			135
(c) R.1060			135
R.2070			135
R.2071			135
R.1062	1 VEH	703420	
(d) R.1062	703421 VEH	734970	135
(e) R.1060			135
R.2070			135
R.2071			135
R.1062			135
R.1062 «CH»	1 VEH	894651	
(f) R.1062 «US»	840300 VEH	880289	
R.1062 «D»	880290 VEH	...	
R.1062 «A»	880290 VEH	...	
R.1062 «CH»	894652 VEH	...	
(g) R.1060			135
R.2070			135
R.2071			135
R.1062	1 VEH	734970	135
(h) R.1060			
R.2070			
R.2071			
R.1062 «CH»	1 VEH	894651	
(j) R.1060			
R.1062	1 VEH	703420	
R.2070			
R.2071			
(k) R.1060			
R.2070			
R.2071			
R.1062	1 VEH	381185	

!!!

135		8241864 -1- 8241863 -1-
-----	---	----------------------------



	n°...	VEH	n°...	VEH	!!!
(m) R.1062	381186	VEH	734970		
(n) R.1062	381186	VEH	...		
(p) R.1060 R.2070 R.2071 R.1062	1	VEH	283715		
(q) R.1062	283716	VEH	...		
(r) R.1060 R.1062	1	VEH	283715		
(s) R.2070 R.2071	1	VEH	4074		
(t) R.2071	4075	VEH	...		
(u) R.1060 R.1062	1	VEH	134817		
(v) R.1062	134818	VEH	...		
(w) R.1062	283716	VEH	734970		
(x) R.1060 R.2070	1 1	VEH VEH	64483 8012		
(y) R.1060 NORMAL R.1060 LUXE R.1062 SERVICE	64484 64484	VEH VEH		261 261
(z) R.1060 R.1062 R.2070 R.2071	8013	VEH	...		
(aa) R.1060 R.2070 R.1062 R.2071	1 1	VEH VEH	69929 2525	2 1	
(ab) R.1062 R.2071	69930 2526	VEH VEH	461432 ...	1 ...	2 136
(ac) R.1062	461433	VEH	...		

	08-00
1	08-00
2	08-00

	7060297 -2-	1080 100856 -2-
136	7060297 -2-	1080 100856 -2-
261	9946005 -1-	



81.13

B P.R. 685

(R. 1060) (R. 1062)

81.13

B P.R. 685

8 200 484 16

8 200 514 16

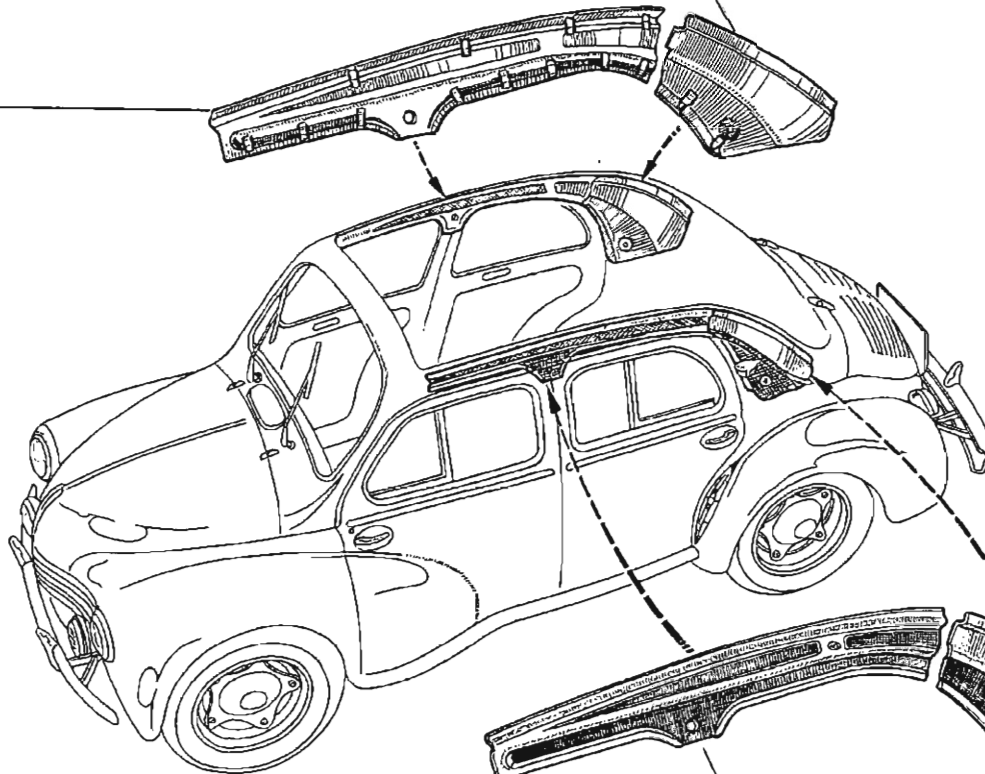

8 200 483 16

8 200 513 16

81.15

A P.R. 685

2 553 922 16

8 220 863

(a) † 9 904 060 16
(d) † 9 904 124 16
(e) 9 904 250

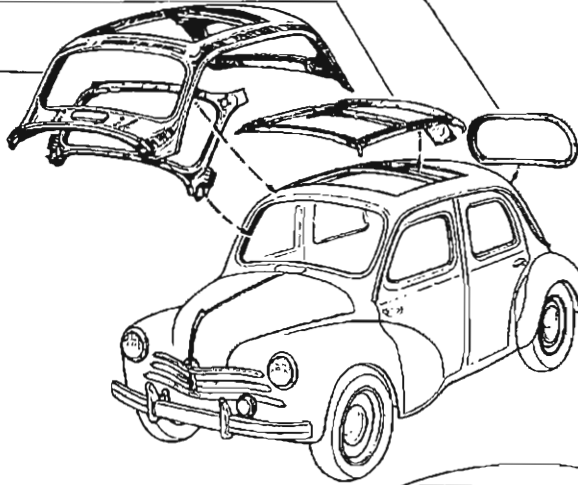

81.15

A P.R. 685

8 520 192

8 516 192

8 221 230

9 904 058 16 † (f)
9 904 125 16 † (g)
9 904 231 (h)

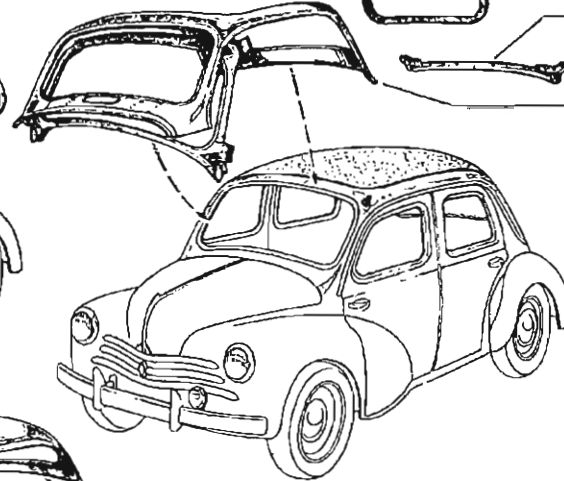

(a) † 9 904 036 16
† 9 904 113 16
(b) † 9 904 123 16
(c) 9 904 229

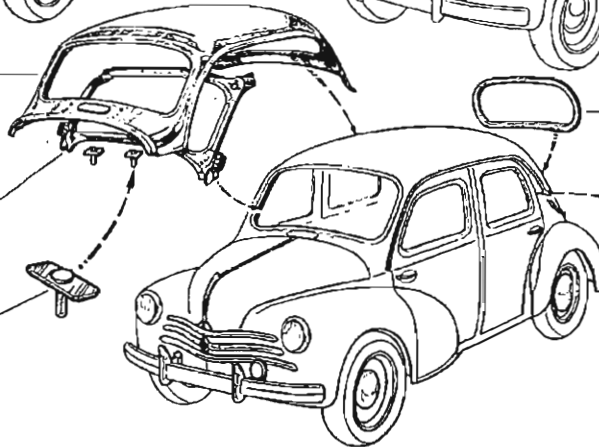

(k) † 8 200 359 16
† 9 940 051 16
(m) 8 201 157
(R. 1060) † 8 200 358 16
(R. 2070) † 8 200 144 16
(R. 2071) † 8 200 360 16
(k) † 9 940 051 16
† 8 201 157 16
(j) 8 202 398

2 553 922 16

7 604 288

(j) 8 242 275

	n°...	n°...	!!!
(a) R.1060			184
R.1062			184
(b) R.1060			184
R.2070			
R.2071	1 VEH	729263	184
R.1062			
(c) R.1060	729264 VEH	...	
R.1062			
R.2070			
R.2071			
(d) R.1060	1 VEH	729263	184
R.1062			184
(e) R.1060	729264 VEH	...	
R.1062			
(f) R.1060			137
			184
R.1062			137
			184
(g) R.1060			137
			184
R.1062	1 VEH	729263	137
			184
(h) R.1060	729264 VEH	...	
R.1062			
(j) R.1062	532893 VEH	...	32
(k) R.1060			
R.2070			
R.2071	1 VEH	532892	32
R.1062			
(m)			32

32

06-00

!!!

137	⚡	6052348 -2-
184	⚡	8242275 -1-



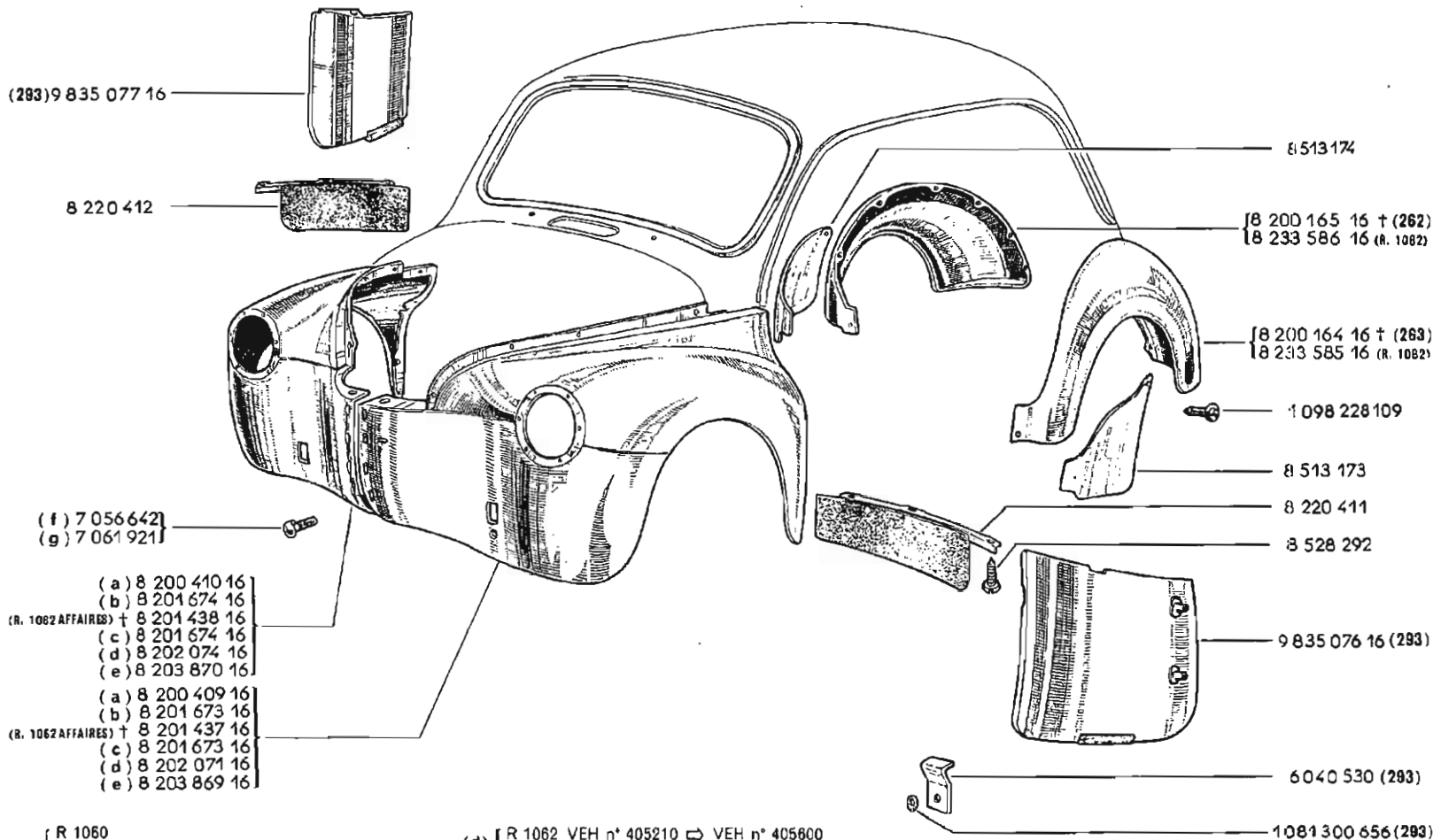

- (a) 8 200 410 16
- (b) 8 201 674 16
- (R. 1062 AFFAIRES) † 8 201 438 16
- (c) 8 201 674 16
- (d) 8 202 074 16
- (e) 8 203 870 16
- (a) 8 200 409 16
- (b) 8 201 673 16
- (R. 1062 AFFAIRES) † 8 201 437 16
- (c) 8 201 673 16
- (d) 8 202 071 16
- (e) 8 203 869 16

- (a) { R 1060
- R 2070
- R 2071
- R 1062 VEH n° 1 ⇨ VEH n° 283715
- (b) { R 1062 VEH n° 283716 ⇨ VEH n° 405209
- R 1062 VEH n° 405601 ⇨ VEH n° 406426
- (c) { R 1062 AFFAIRES VEH n° 1 ⇨ VEH n° 405209 (f) R 1062 VEH n° 283716 ⇨ VEH n° 311700
- R 1062 AFFAIRES VEH n° 405601 ⇨ VEH n° 406426 (g) R 1062 VEH n° 311701 ⇨ VEH n° ...
- (d) { R 1062 VEH n° 405210 ⇨ VEH n° 405600
- R 1062 VEH n° 406427 ⇨ VEH n° ...
- (e) { R 1062 « US » VEH n° 840300 ⇨ VEH n° 880289
- R 1062 « D » « A » VEH n° 880290 ⇨ VEH n° ...
- R 1062 « CH » VEH n° 894652 ⇨ VEH n° ...

262	⊕	8233586 16 - 1-
263	⊕	8233585 16 - 1-
283		06-00

82.01

B P.R. 685

(R. 1060) (R. 2070) (R. 2071)

82.01

B P.R. 685

(R. 1080) (R. 2070) † 9 909 171 16
 (d) † 9 909 217 16
 † 9 909 552 16
 9 909 612 16

(g) † 8 231 384
 (h) 8 234 580 04

(R. 1060) { (b) † 7 604 341
 6 054 618
 † 6 036 713
 (c) † 7 604 349
 6 058 128
 † 6 033 061
 † 7 604 341
 6 054 618

(R. 1080 ⚓) 8 231 376

(R. 1080 ⚓) 8 221 150

(R. 1080 ⚓) { † 9 909 230 16
 9 909 614 16

{ 6 038 900 «US» (R. 1080)
 6 032 927 (a)

{ 8 231 383 † (g)
 8 234 579 04 (h)

{ 6 041 584 †
 6 045 808 †
 7 604 421

{ 9 909 169 16 † (R. 1080) (R. 2070)
 9 909 216 16 †
 9 909 551 16 †
 9 909 611 16

8 231 375 (R. 1080 ⚓)

{ 9 909 231 16 † (R. 1080 ⚓)
 9 909 613 16

8 221 149 (R. 1080 ⚓)

6 035 387 { (e)
 (f)
 (i)

6 044 596

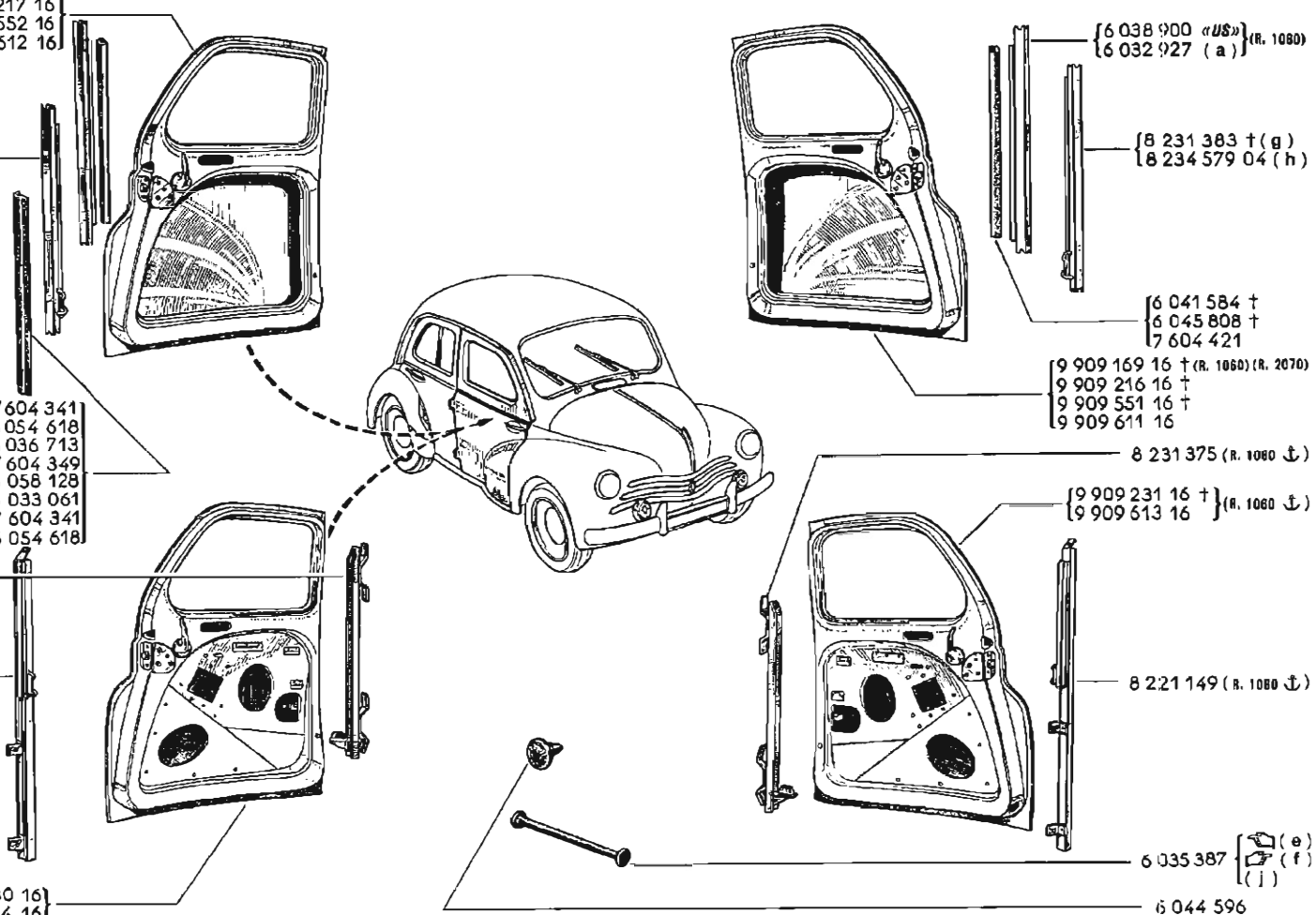

	n'...		n'...		!!!
(a) R.1060	1 VEH		109936	76	
R.2070	1 VEH		10101		
(b)	1 VEH		78722		
(c)	78723 VEH		...		
(d)					27
(e) R.1060	9167 VEH		...		
(f) R.1060	945 VEH		...		
(g) R.1060	109937 VEH		...	76	
(h) R.1060	109937 VEH		...	76	
R.2070	10102 VEH		...		
R.2071					
(i) R.2071					
R.2070	1459 VEH		...		
(k) R.2070	1 VEH		10101		

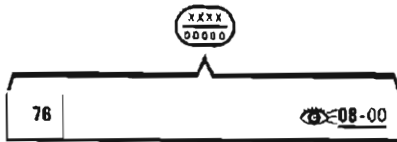

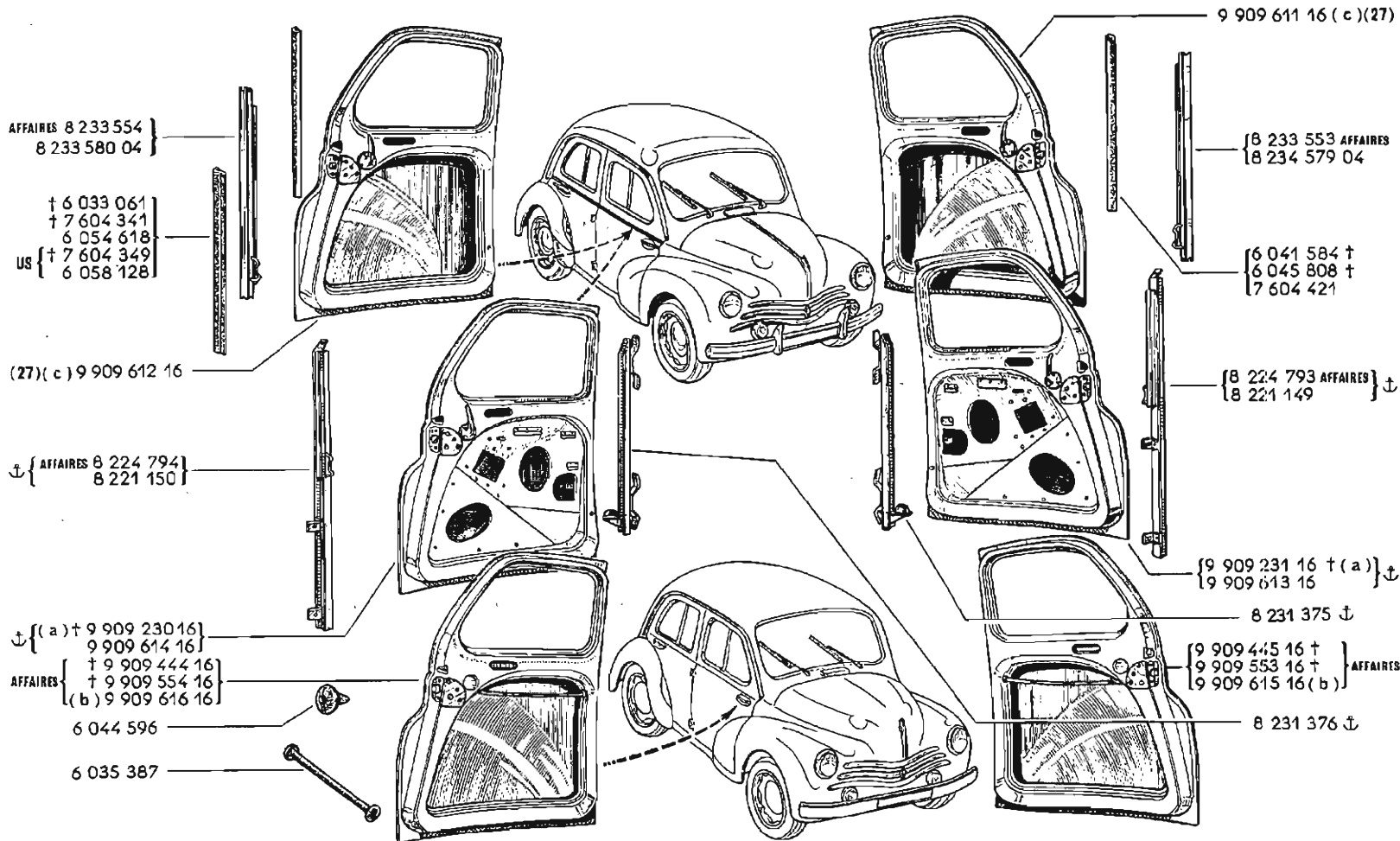

- (a) VEH n° 1 ⇨ VEH n° 532892
- (b) VEH n° 1 ⇨ VEH n° 698997
- (c) AFFAIRES VEH n° 698998 ⇨ VEH n° ...

(R. 2070)(R. 2071) { † 9 909 189 16 }
9 909 185 16 }

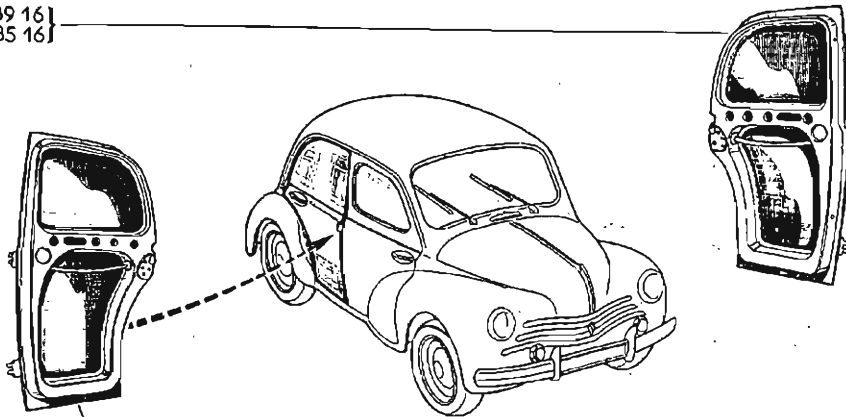

(R. 2070)(R. 2071) { † 9 909 188 16 }
9 909 184 16 }

(R. 1080) { † 9 909 168 16 }
9 909 609 16 }

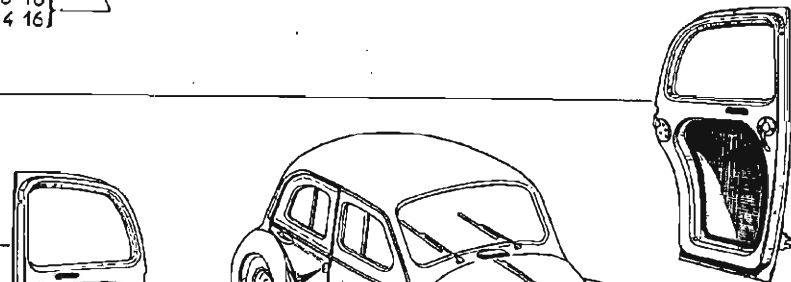

(R. 1080) { † 9 909 170 16 }
9 909 610 16 }

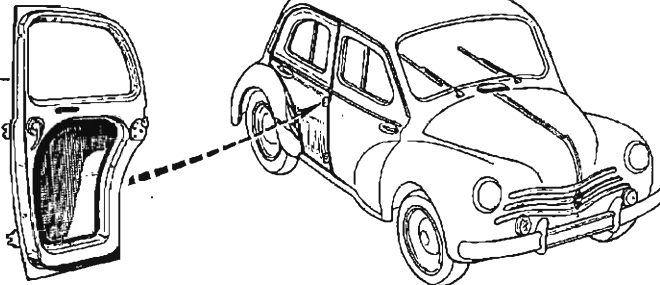

6 044 596

7 064 341 †	} (a)	} US (R. 1080)
6 054 618		
6 036 713 †	} (b)	
7 604 349 †		
6 058 128		
6 033 061 †		
7 604 341 †		
6 054 618		

8 240 674 †	} (R. 1080)(US)
6 038 900 †	
8 240 197 † (28)	
6 032 927	

(a) VEH n° 1 ⇨ VEH n° 78722
(b) VEH n° 78723 ⇨ VEH n° ...

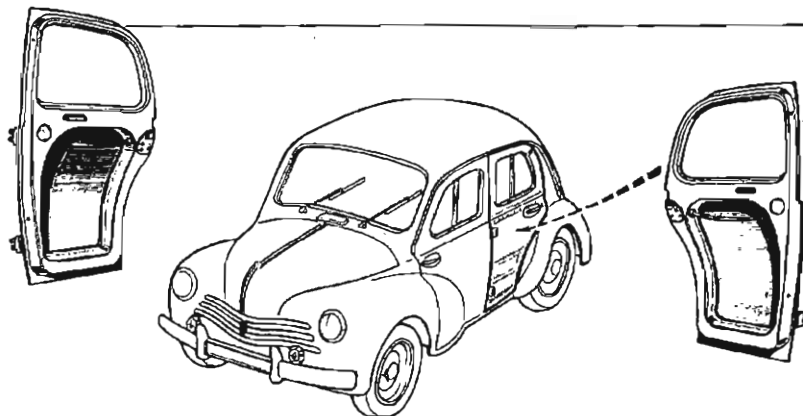

9 909 442 16 †
 9 909 503 16 †
 9 909 618 16 (a)
 9 909 610 16 (b)

SERVICE
AFFAIRES

9 909 443 16 †
 9 909 502 16 †
 9 909 617 16 (a)
 9 909 609 16 (b)

9 909 609 16

9 909 610 16

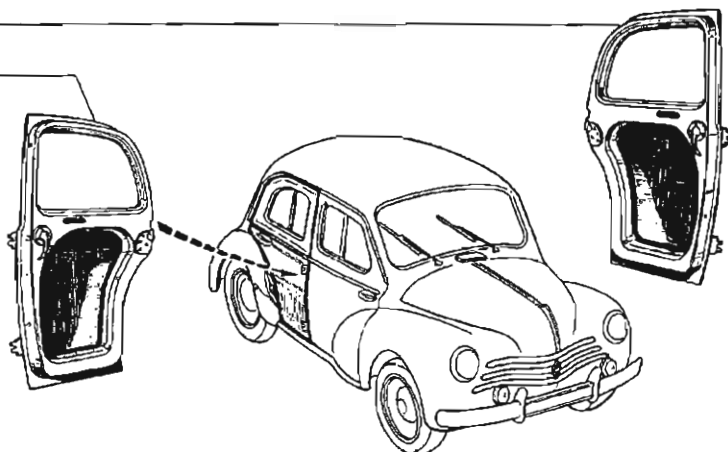

6 044 596

6 033 061 †
 7 604 341 †
 6 054 618
 7 604 349 † } US
 6 058 128 }

8 241 616 † (c) } AFFAIRES
 6 050 829 (d) }
 8 240 674 † }
 6 038 900 † } US
 6 069 324 }
 8 240 197 † (c)(2B)
 6 032 927 (d)

- (a) VEH n° 1 ⇨ VEH n° 698997
 (b) VEH n° 698998 ⇨ VEH n° ...
 (c) VEH n° 1 ⇨ VEH n° 802830
 (d) VEH n° 802831 ⇨ VEH n° ...

82.05

B P.R. 685

(R. 1060) (R. 1062 VEH. n° 1 ⇔ VEH. n° 345360)

82.05

B P.R. 685

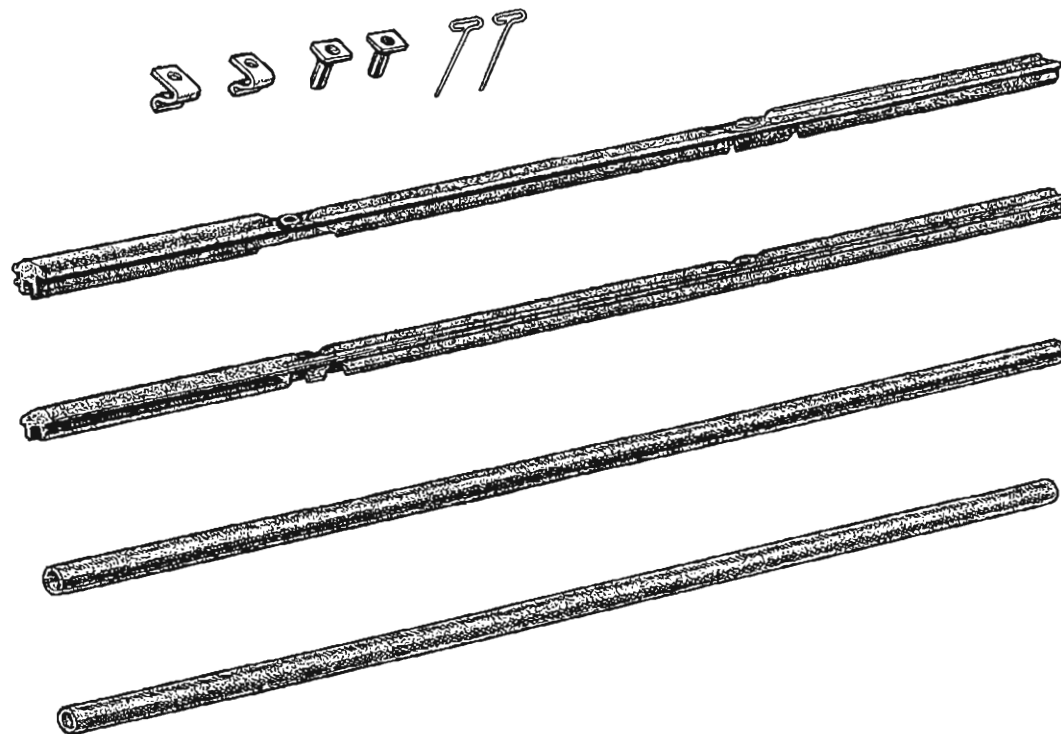

9 989 108

(a)(R. 1060) { 8 513 212 }
 { « US » 8 515 236 }

(b)(R. 1062) { « US » { † 8 515 527 }
 { 8 525 073 }
 { † 8 515 526 }
 { † 8 515 528 }
 { † 8 525 072 }
 { 8 525 074 }
(R. 1060) AFFAIRES 8 525 993
 (c) 8 525 074 }

(B. 1060) (R. 1082) { « US » { † 8 512 761 }
 { 8 527 365 }
 { † 8 512 760 }
 TRIPLEX 8 525 153
 VISURIT 8 525 900 }

4 264 544

(R. 1060) (R. 1082) { « US » { † 8 525 037 }
 { 8 525 076 }
 { † 8 515 400 }
 { † 8 515 524 }
 { † 8 525 075 }
 { 8 525 077 }
 ↓

(a)(R. 1060) « US » 8 513 824]
(d) 8 515 408]

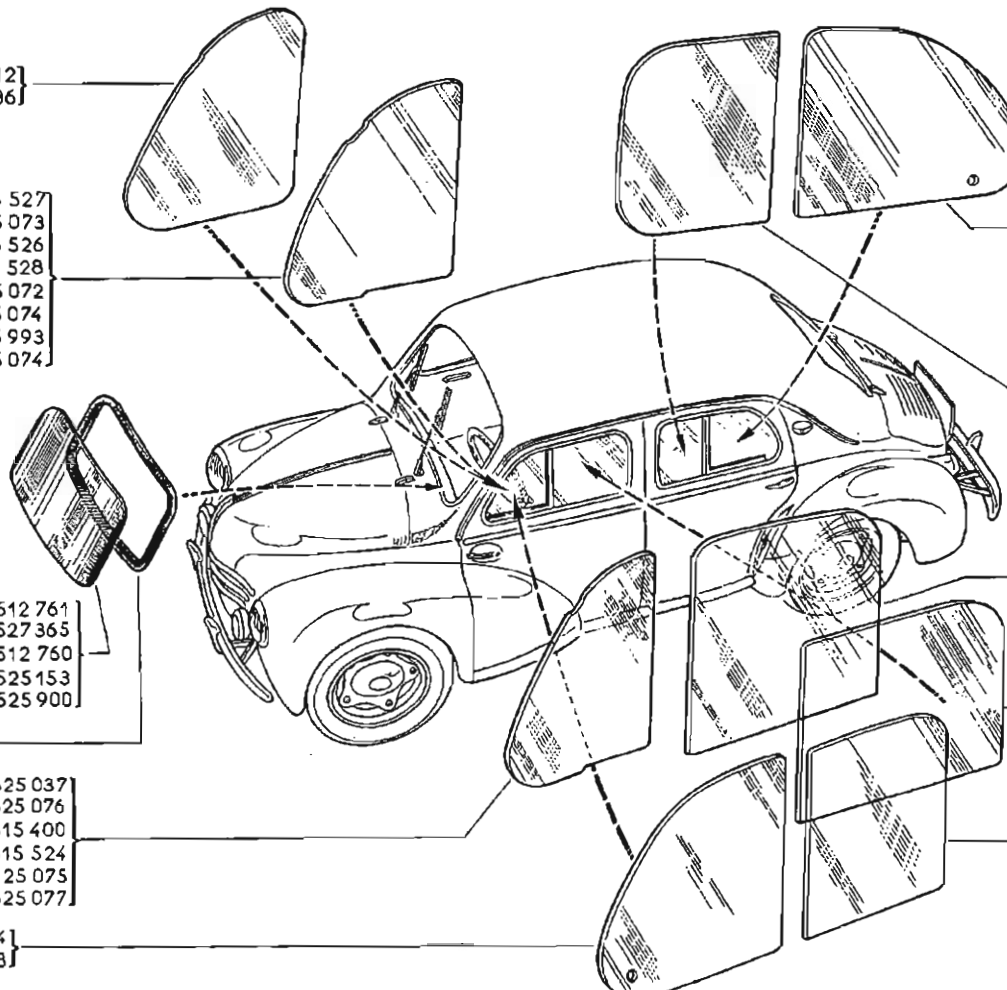

{ 8 513 575† } « US » (h)
8 513 833 }
8 511 406 { (i)
 (m)
8 513 319 SECURIT (k)
8 525 992 SPLINTEX (k)
 (n)
 (p)

{ 8 513 830 (e) « US » }
8 515 431† (f) } (R. 1080)
8 515 309† (a) }
8 525 994 (g)
8 525 701 (R. 1062) SERVICE

{ 8 525 038 « US » }
8 515 399 SECURIT } (R. 1080) (R. 1082)
8 515 525 TRIPLEX } ↓

{ 8 513 530 (q) « US » }
8 525 995 SPLINTEX (r)
8 515 529 SECURIT (s)
8 515 531 TRIPLEX (t)

{ 8 513 830 « US » (u) }
8 515 431† (f) } (R. 1080)
8 513 309† (a) }
8 525 994 (f)

	n°...	n°...	!!!
(a)	1 VEH	109936	76
(b)	109937 VEH	...	76
(c) R.1062 R.2070 R.2071	10102 VEH	...	
(d) R.1060 R.2070	1 VEH 1 VEH	109936 10101	76
(e) R.1060 R.1062			138
(f)	1 VEH	109936	
(g) R.1080 R.1080 R.1082 R.2070	1 VEH 109937 VEH 1 VEH	109936 ... 10101	76 139
(h)			29
(j) R.1080	1 VEH	26631	
(k) R.1080	26632 VEH	...	
(m) R.1060	1 VEH	2333	
(n) R.1080	2334 VEH	...	
(p) R.1062			
(q) R.1060 R.1062	109937 VEH	...	76
(r) R.1060 R.1062 AFFAIRES	109937 VEH	...	
(s) R.1060 R.1062 R.2071 R.2070	109937 VEH 10102 VEH	...	76
(t) R.1060 R.1062 R.2070 R.2071	109937 VEH 10102 VEH	...	
(u)	1 VEH	109936	138

XXXX
00000

76	08-00
----	-------

!!!

29		3530097 -1- 6036633 -1-
138		6036588 -1- 6036713 -1- et 7604348 -1-
139		5538880 -1-

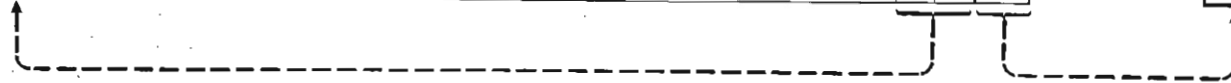

82.09

B P.R. 685

⚓ (R. 1060) (R. 1062)

82.09

B P.R. 685

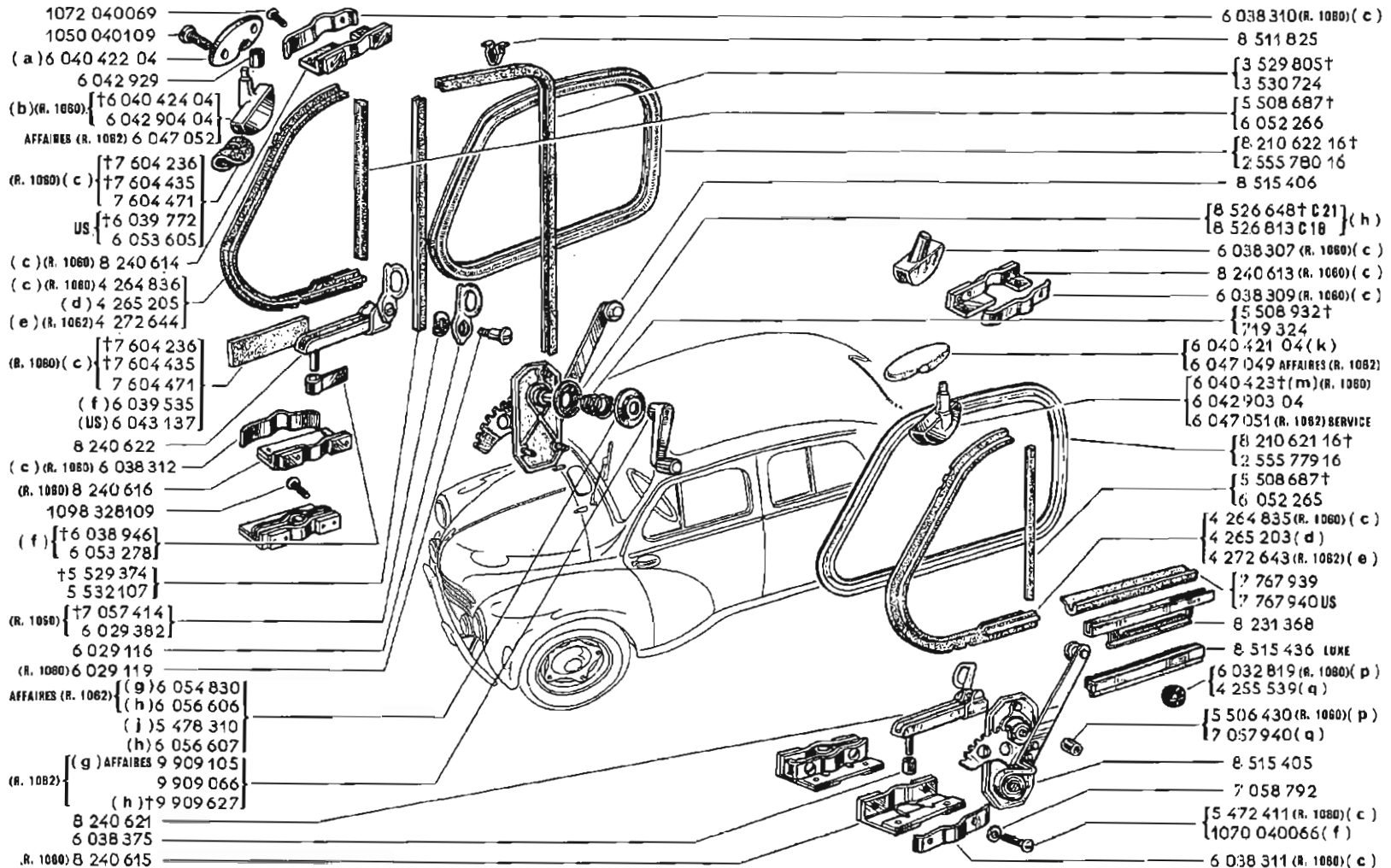
C 18 }
C 21 } 100-00

	n°...	n°...	!!!	!!!
(a) R.1060 R.1062	109937 VEH	...	76	31
(b)	109937 VEH	...	76	30 42
(c)	1 VEH	109936	76	
(d) R.1060 R.1062	109937 VEH 1 VEH	...	76	
(e)	345361 VEH	...		
(f) R.1060 R.1062	109937 VEH	...	76	
(g)	1 VEH	532892		32
(h) R.1062	532893 VEH	...	32	
(j) R.1060 R.1062	1 VEH	532892		32
(k) R.1060 R.1062	109937 VEH	...	76	32
(m) R.106 ^A	109937 VEH	...	76	30 43
(n) R.1060 R.1062	109937 VEH	...		
(p)	91753 VEH	96728		
(q) R.1060 R.1062	96729 VEH	...		

XXXX
00000

32	08-00
76	08-00

!!!

30	08-00
31	6040424 -1- 6042904 -1-
32	6042903 -1-
42	6040422 -1-
43	6040421 -1-



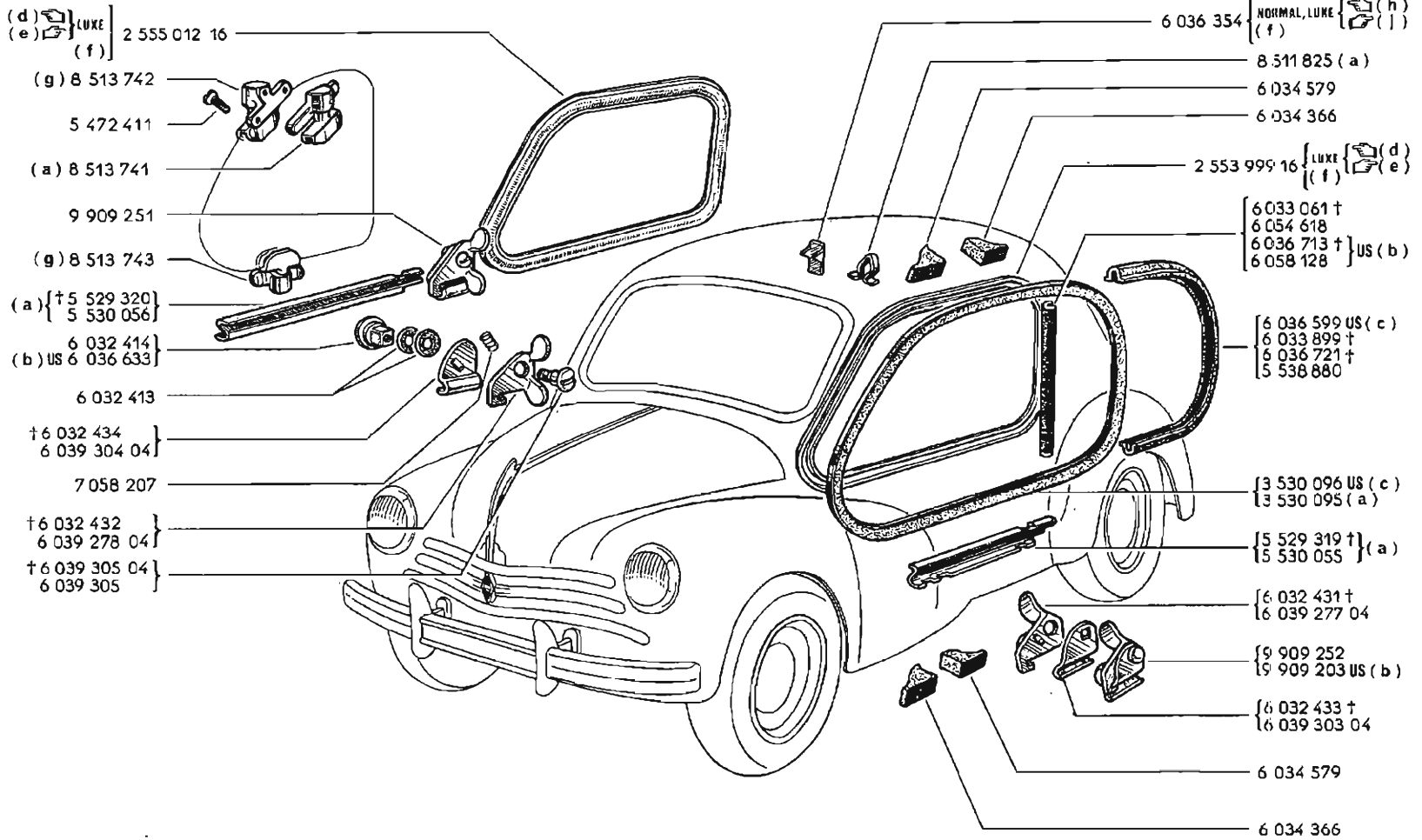

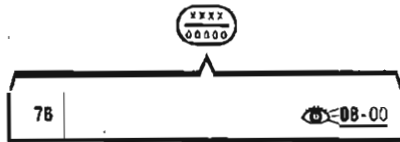

	n°...	n°...	!!!	!!!
(a)			76	
(b)	78723 VEH			
(c)	1 VEH	112694		
(d)	44277 VEH	109936	76	
(e)	4040 VEH	109936	76	
(f)	1 VEH	109936		
(g)			76	140
(h)	26632 VEH	109936	76	
(j)	2334 VEH	109936	76	



82.13

(R. 1060 NORMAL)(R. 1060 LUXE VEH. n°109937⇒VEH. n° ...)(R. 1062)(R. 2070)(R. 2071)

82.13

A P.R. 685

A P.R. 685

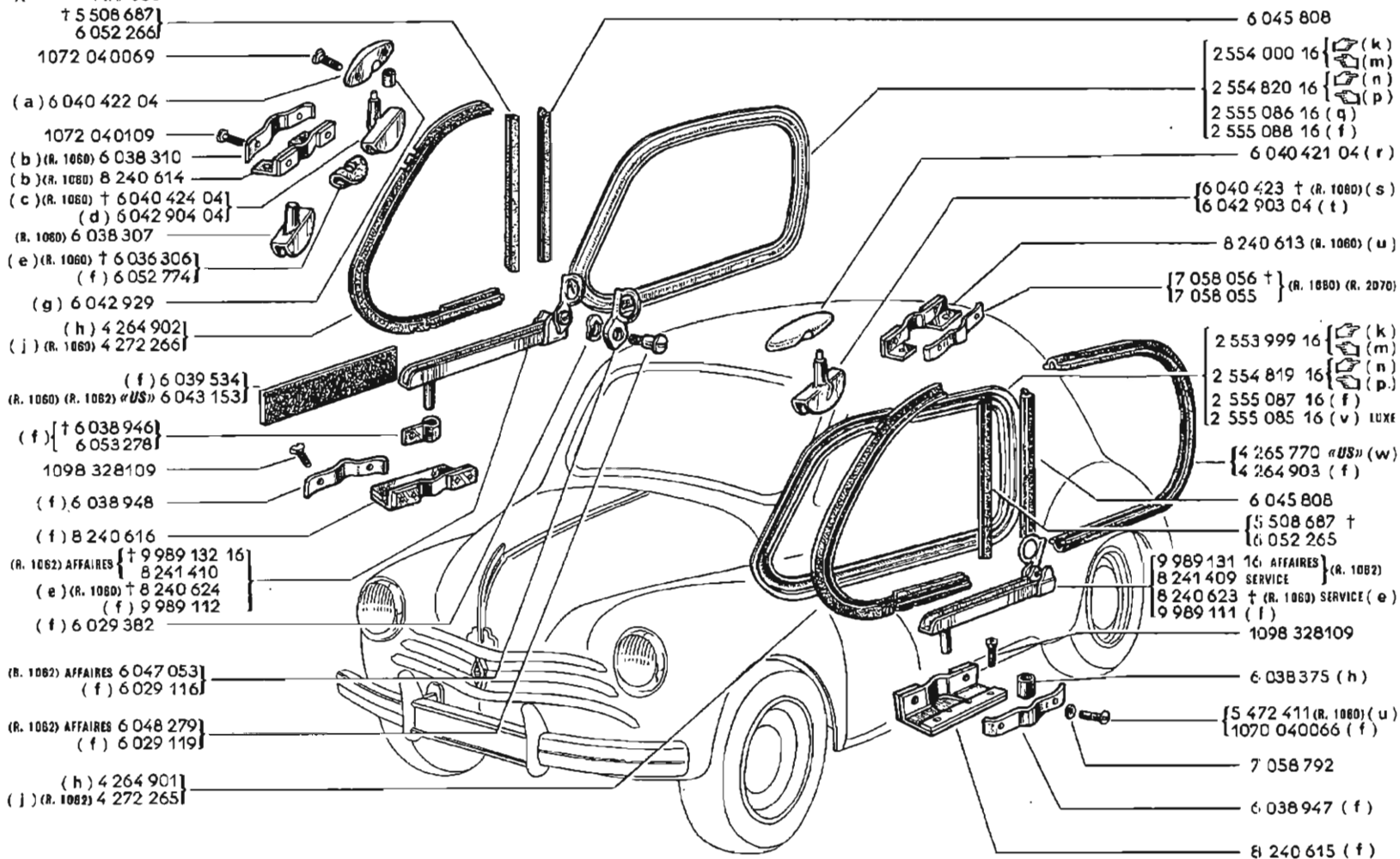

	n°...		n°...	!!!
(a) R.1060	109937 VEH	...	76	31
R.1062				
R.2070	10102 VEH	...		31
R.2071				
(b)			76	
(c)	109937 VEH	...	76	30 42
(d) R.1060	109937 VEH	...		
R.1062				
R.2070	10102 VEH	...		30 42
R.2071				
(e)	109937 VEH	...	76	
(f) R.1060	109937 VEH	...	76	
R.1062				
R.2071				
R.2070	10102 VEH	...		
(g) R.1060	109937 VEH	...	76	
R.1062				
R.2071				
R.2070	10102 VEH	...		
(h) R.1060	109937 VEH	...	76	
R.1062	1 VEH	345360		
R.2070	10102 VEH	...		
R.2071				
(j)	345361 VEH	...		
(k) R.1060	1 VEH	3730		
	4040 VEH	109936	76	
(m) R.1060	1 VEH	33703		
	44277 VEH	109936	76	
R.2070	1 VEH	10101		
(n) R.1060	3731 VEH	4039		
(p) R.1060	33704 VEH	44276		
(q) R.1060	109937 VEH	...		
NORMAL				
R.1062				
(r) R.1060	109937 VEH	...	76	32
R.1062				
R.2070	10102 VEH	...		
R.2071				
(s)	109937 VEH	...	76	30 43
(t) R.1060	109937 VEH	...		
R.1062				
R.2070	10102 VEH	...		
R.2071				
(u)	1 VEH	109936	76	
(v) R.1060	109937 VEH	...	76	
R.1062				
(w) R.1060	112695 VEH	...		
R.1062				

76	08-00
----	-------

30	08-00
31	6040424 -1- 6042904 -1-
32	6042903 -1-
42	6040422 -1-
43	6040421 -1-

82.15

A P.R. 685

(R. 1060) (R. 1062)

82.15

A P.R. 685

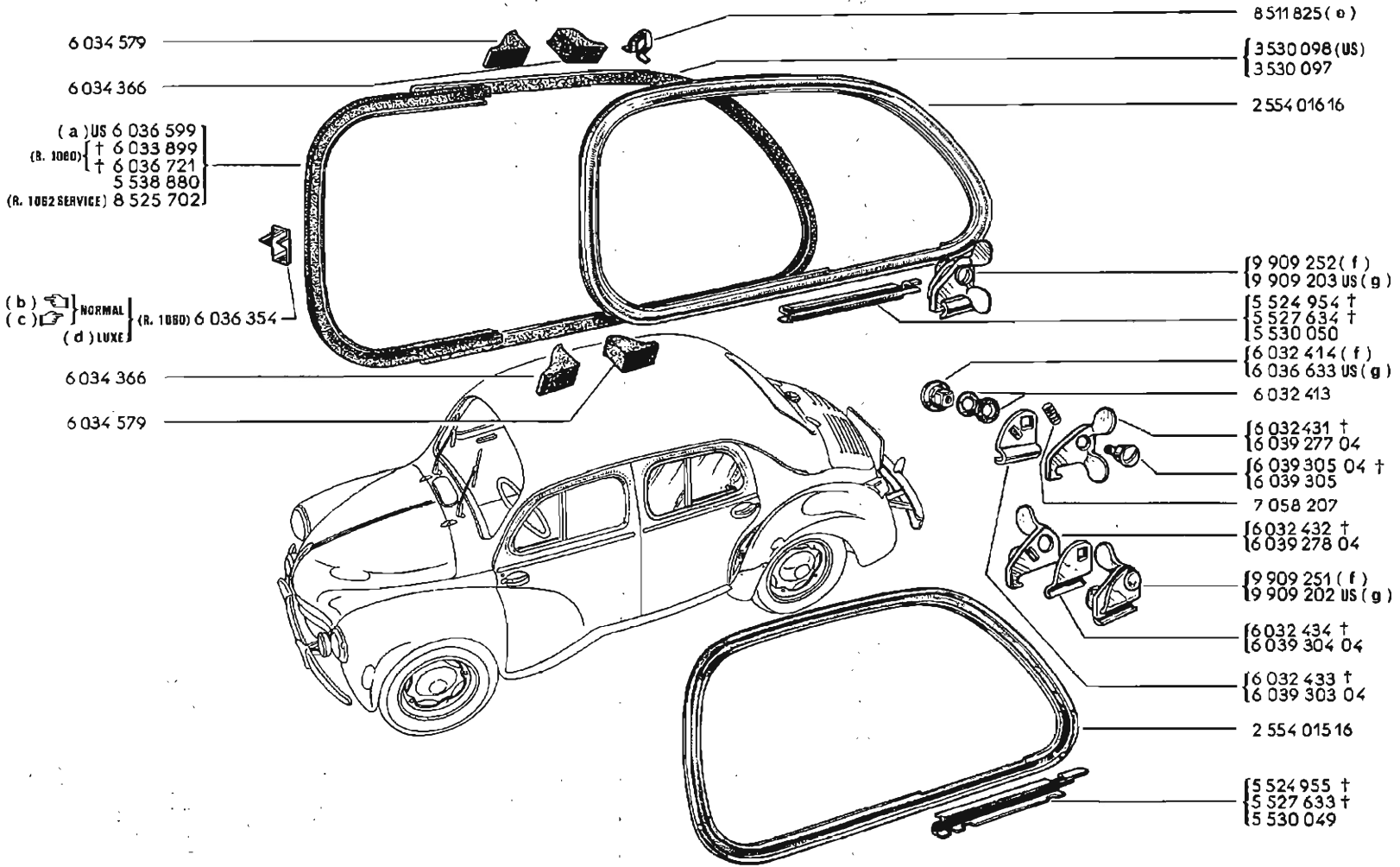

6 034 579

6 034 366

(a) US 6 036 599

(R. 1060) { † 6 033 899

† 6 036 721

5 538 880

(R. 1062 SERVICE) 8 525 702

(b) NORMAL

(c) LUXE

(R. 1060) 6 036 354

6 034 366

6 034 579

8 511 825 (e)

{ 3 530 098 (US)
3 530 097

2 554 016 16

{ 9 909 252 (f)
9 909 203 US (g)

5 524 954 †

5 527 634 †

5 530 050

{ 6 032 414 (f)

6 036 633 US (g)

6 032 413

{ 6 032 431 †
6 039 277 04

{ 6 039 305 04 †
6 039 305

7 058 207

{ 6 032 432 †
6 039 278 04

{ 9 909 251 (f)
9 909 202 US (g)

{ 6 032 434 †
6 039 304 04

{ 6 032 433 †
6 039 303 04

2 554 015 16

{ 5 524 955 †
5 527 633 †
5 530 049

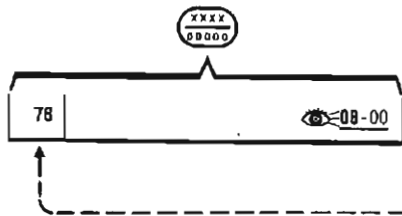

	n°...	☐	n°...	⚡	⚡	!!!
(a)	1	VEH	112694			
(b)	26632	VEH	109936	76		
(c)	2334	VEH	109936	76		
(d)	1	VEH	109936			
(e) R.1060	1	VEH	109936	76		
R.1062						
(f) R.1060						
R.1062						
R.1060 US	1	VEH	78722			
(g) R.1060	78723	VEH	...			
R.1062						

A P.R. 685

A P.R. 685

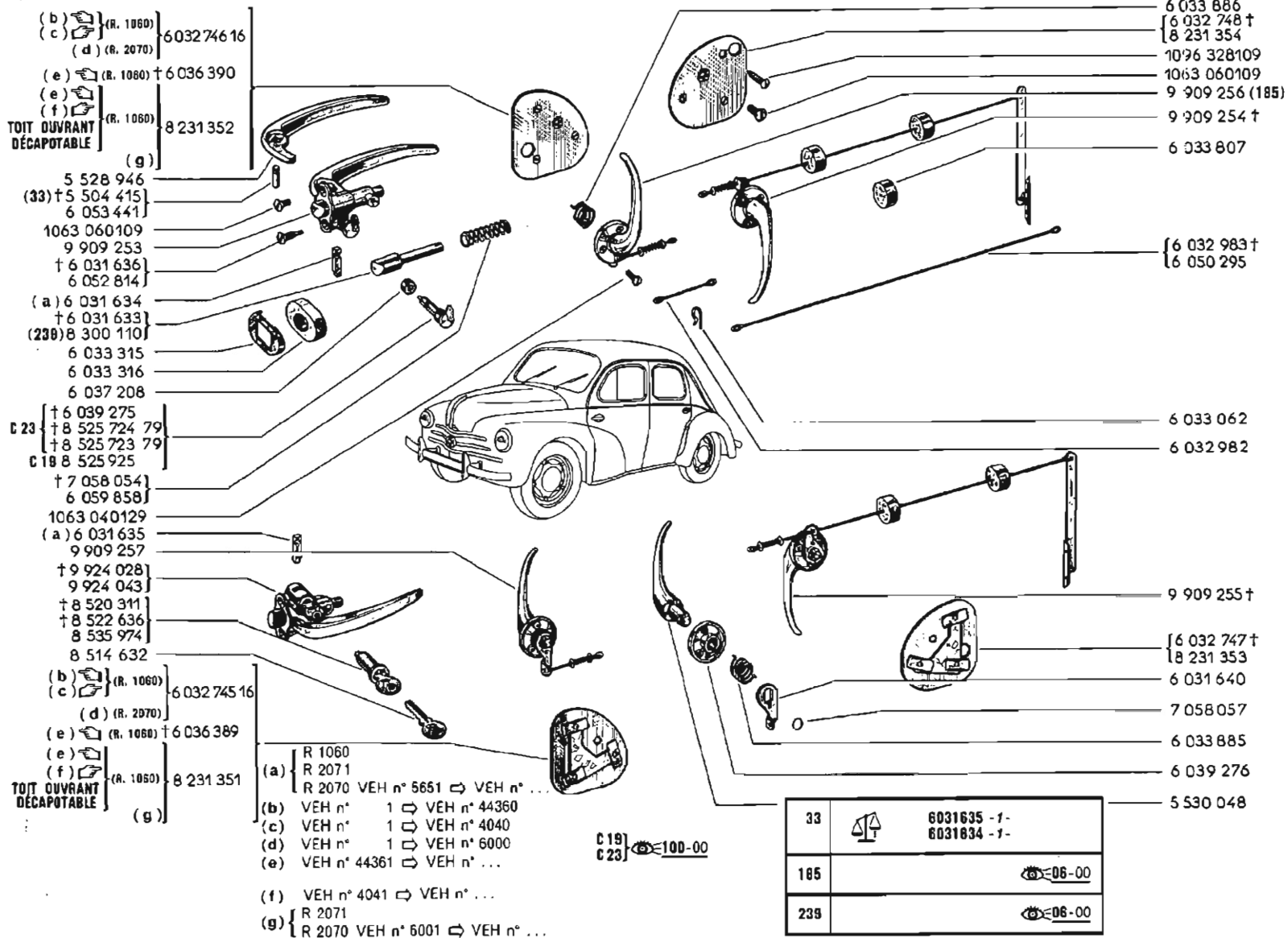

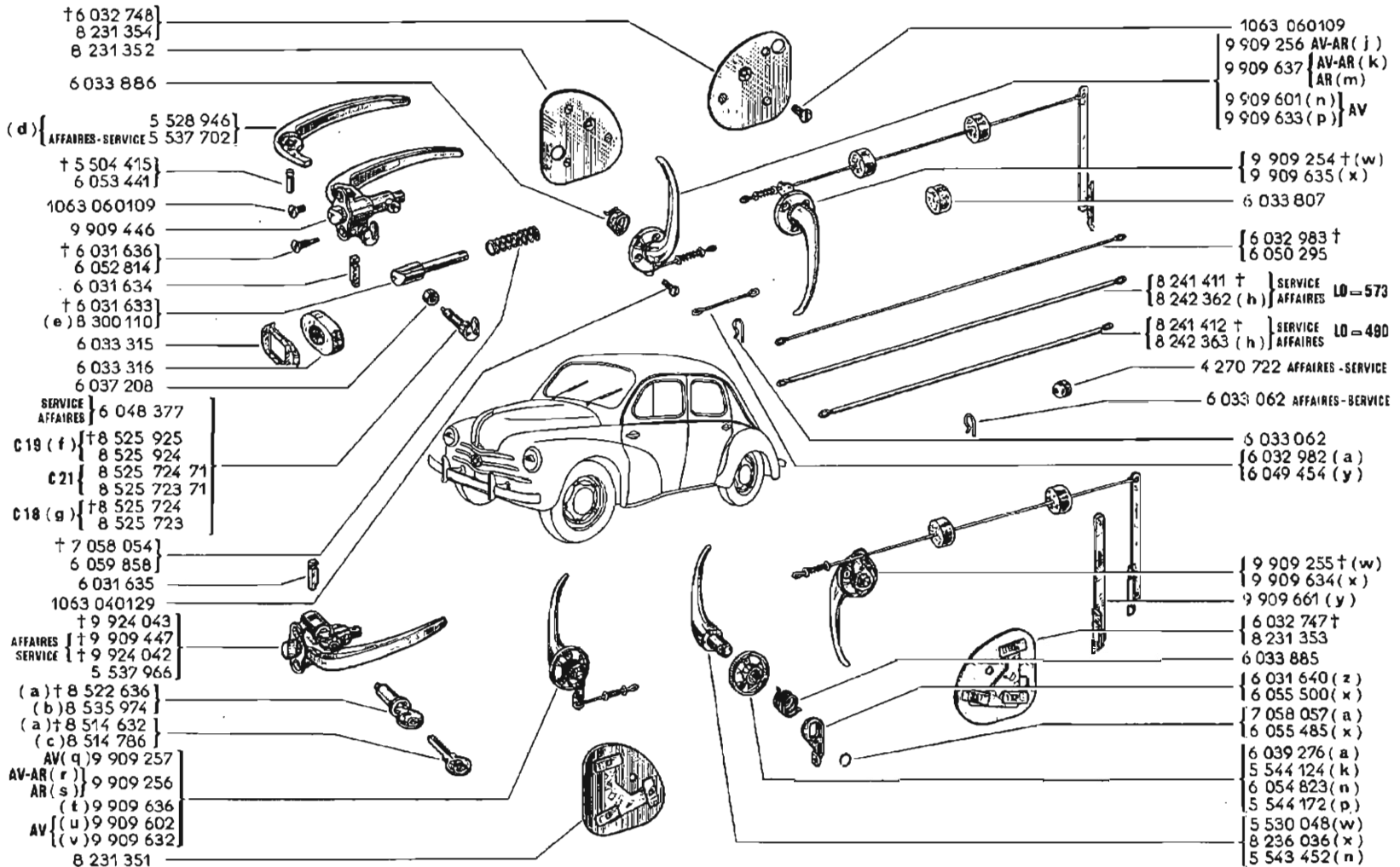

	n°...	n°...	!!!
(a) NORMAL	1 VEH	...	
LUXE	1 VEH	...	
GRAND LUXE	1 VEH	...	
SERVICE	1 VEH	...	
SPORT	1 VEH	532892	32
TOIT OUVRANT	1 VEH	532892	32
DÉCAPOTABLE	1 VEH	532892	32
(b) SPORT	532893 VEH	...	32
TOIT OUVRANT	532893 VEH	...	32
DÉCAPOTABLE	532893 VEH	...	32
SPORT	1 VEH	532892	32
TOIT OUVRANT	1 VEH	532892	32
DÉCAPOTABLE	1 VEH	532892	32
NORMAL	1 VEH	...	
LUXE	1 VEH	...	
GRAND LUXE	1 VEH	...	
SERVICE	1 VEH	...	
(c) SPORT	532893 VEH	...	32
TOIT OUVRANT	532893 VEH	...	32
DÉCAPOTABLE	532893 VEH	...	32
(d)			33
(e)			239
(f)	1 VEH	405209	
	405601 VEH	406426	
(g)	405210 VEH	405600	
	406427 VEH	...	
(h)	1 VEH	698997	
(j) SERVICE			185
LUXE			185
GRAND LUXE			185
NORMAL			185
SPORT	1 VEH	532892	32
TOIT OUVRANT	1 VEH	532892	32
DÉCAPOTABLE	1 VEH	532892	32
AFFAIRES	1 VEH	532892	32
(k) SPORT	532893 VEH	...	32
TOIT OUVRANT	532893 VEH	...	32
DÉCAPOTABLE	532893 VEH	...	32
(m) AFFAIRES	532893 VEH	...	32
(n) AFFAIRES	1 VEH	532892	32
(p) AFFAIRES	532893 VEH	698997	32
AFFAIRES	698998 VEH	...	

XXXX
00000

32
06-00

!!!

33

8031635 -1-
6031634 -1-

185

06-00

239

06-00

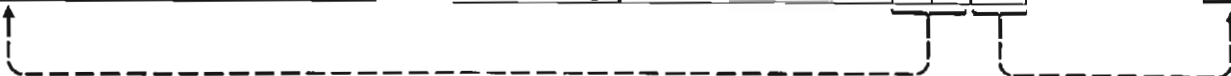

	n°...	n°...	!!!	!!!
(q) SERVICE LUXE GRAND LUXE NORMAL				
(r) SPORT	1 VEH	532892	32	185
TOIT OUVRANT	1 VEH	532892	32	185
DÉCAPOTABLE	1 VEH	532892	32	185
AFFAIRES	1 VEH	532892	32	185
(s) SPORT				185
LUXE				185
GRAND LUXE				185
NORMAL				185
(t) SPORT	532893 VEH	...	32	185
TOIT OUVRANT	532893 VEH	...	32	185
DÉCAPOTABLE	532893 VEH	...	32	185
AFFAIRES	532893 VEH	...	32	185
(u) AFFAIRES ⚓	1 VEH	532892	32	
(v) AFFAIRES ⚓	532893 VEH	698997	32	
(w) SERVICE LUXE GRAND LUXE NORMAL				
SPORT	1 VEH	532892	32	
TOIT OUVRANT	1 VEH	532892	32	
DÉCAPOTABLE	1 VEH	532892	32	
AFFAIRES	1 VEH	532892	32	
(x) SPORT	532893 VEH	...	32	
TOIT OUVRANT	532893 VEH	...	32	
DÉCAPOTABLE	532893 VEH	...	32	
AFFAIRES	532893 VEH	...	32	
(y) SPORT	532893 VEH	...	32	
TOIT OUVRANT	532893 VEH	...	32	
DÉCAPOTABLE	532893 VEH	...	32	
AFFAIRES	698998 VEH	...		
(z) NORMAL				
SERVICE				
LUXE				
GRAND LUXE				
SPORT	532893 VEH	...	32	
TOIT OUVRANT	532893 VEH	...	32	
DÉCAPOTABLE	532893 VEH	...	32	
AFFAIRES	532893 VEH	...	32	

32

xxx
00000

08-00

185

!!!

08-00

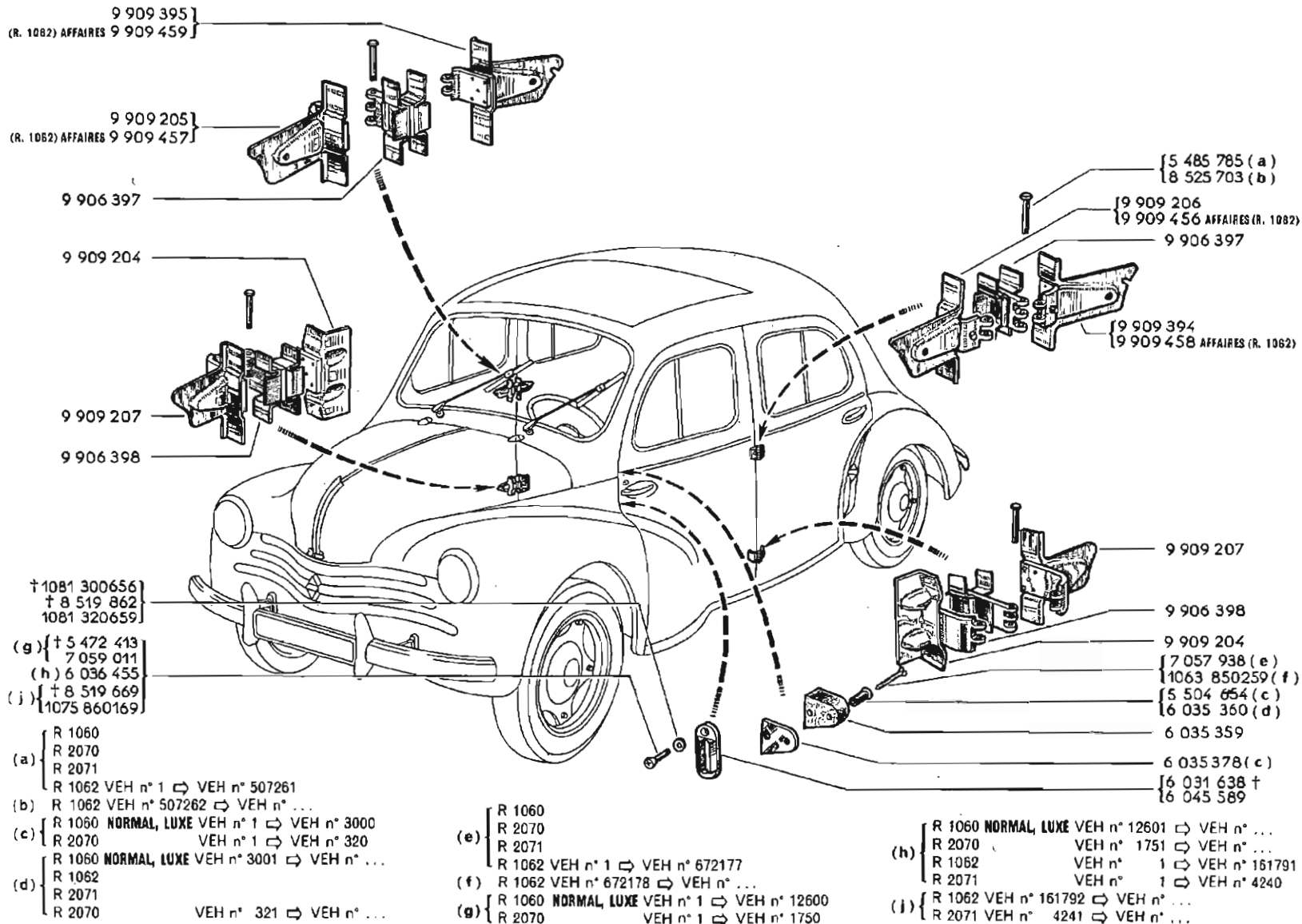

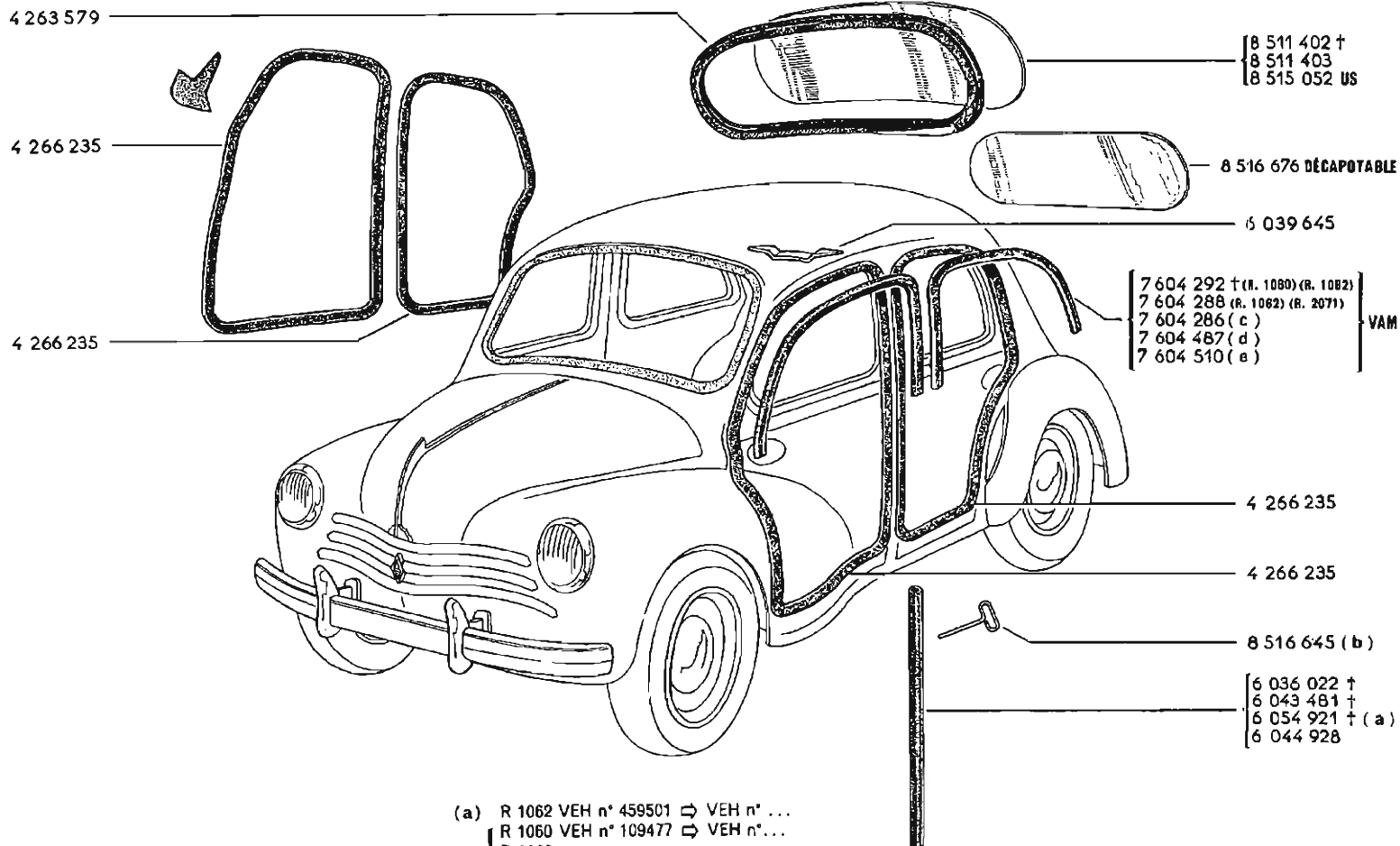

- (a) R 1062 VEH n° 459501 ⇨ VEH n° ...
R 1060 VEH n° 109477 ⇨ VEH n° ...
- (b) R 1062
R 2071
R 2070 VEH n° 10077 ⇨ VEH n° ...
- (c) R 1062 AFFAIRES VEH n° 1 ⇨ VEH n° 306904
- (d) R 1062 AFFAIRES VEH n° 306905 ⇨ VEH n° 405209
R 1062 AFFAIRES VEH n° 405601 ⇨ VEH n° 406426
- (e) R 1062 AFFAIRES VEH n° 405210 ⇨ VEH n° 405600
R 1062 AFFAIRES VEH n° 406427 ⇨ VEH n° ...

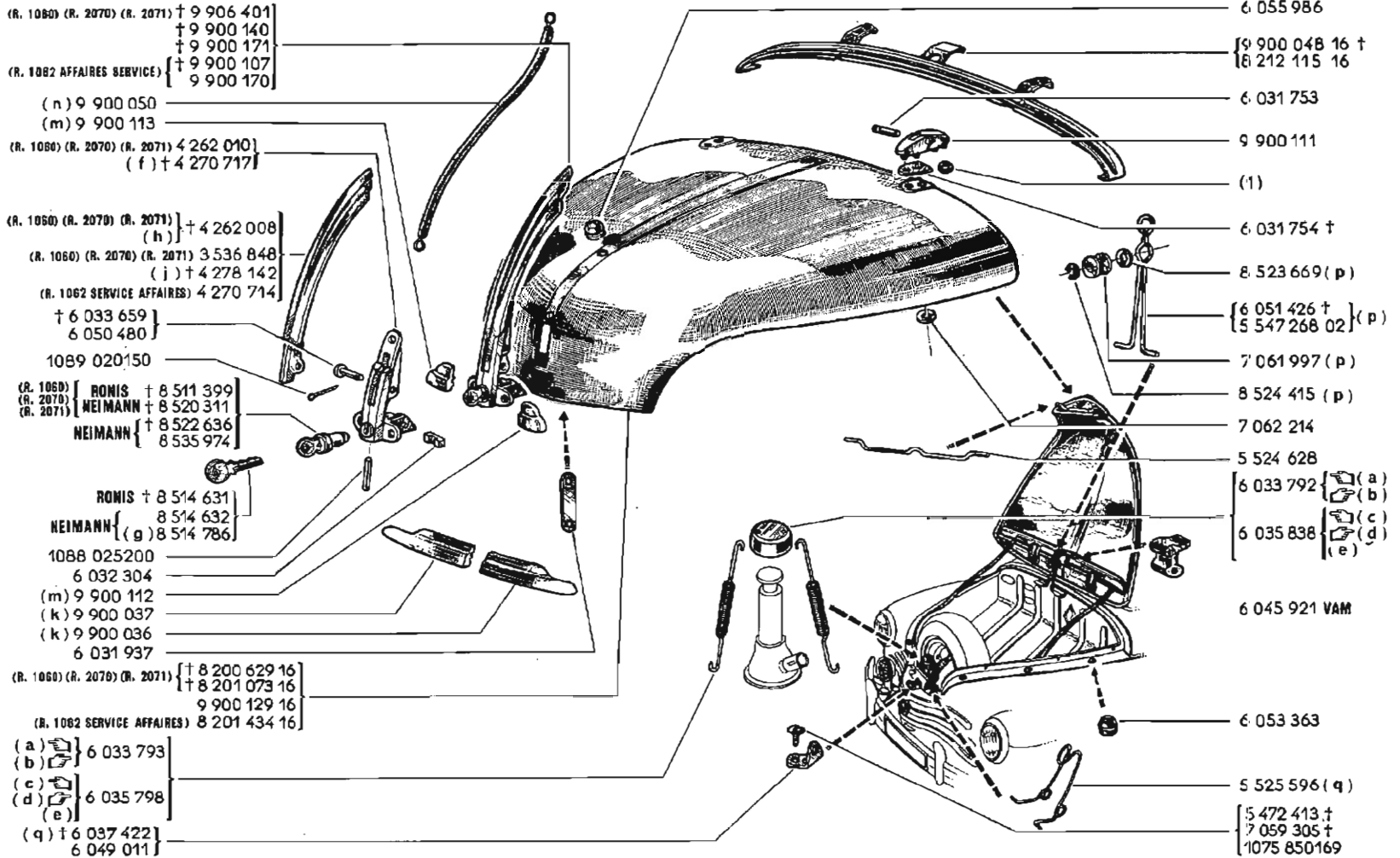

(1)

6054376 E = 1,5
7059054 E = 2

	n°...	n°...	!!!
(a) R.1060 NORMAL	1 VEH	9479	
R.1060 LUXE	1 VEH	9479	
R.2070	1 VEH	1507	
(b) R.1060 NORMAL	1 VEH	985	
R.1060 LUXE	1 VEH	985	
(c) R.1060 NORMAL	9480 VEH	116110	
R.1060 LUXE	9480 VEH	116110	
(d) R.1060 NORMAL	986 VEH	116110	
R.1060 LUXE	986 VEH	116110	
(e) R.1060 GD LUXE	1 VEH	116110	
R.1060 TOIT OUVRANT	1 VEH	116110	
R.1060 DÉCAPOTABLE	1 VEH	116110	
R.2070	1508 VEH	10258	
(f) R.1062 SERVICE			
R.1062 AFFAIRES			264
(g) R.1062	532893 VEH	...	32
(h) R.1062			
(j) R.1062 «OH»			285
(k) R.1060			
R.2070			
R.2071			
R.1062	1 VEH	283715	
(m) R.1062	283716 VEH	...	
(n) R.1060			
R.2070			
R.2071			
R.1062	1 VEH	405209	
R.1062	405601 VEH	405426	
(p) R.1062	405210 VEH	405600	
R.1062	406427 VEH	...	
(q)			142

32

08-00

142



7058305 -2-

264



4262010 -1-

285

3536848 -1-

(d) 
(e) 
(f) 

9 900 111

(d) 
(e) 
(f) 

6 033 724

† 4 255 539 }
6 035 709 }

(R. 1060) (R. 2070) 6 039 685

(R. 1060) (R. 1062) † 9 900 063

RONIS (R. 1060) † 8 514 631

NEIMANN { (p) 8 514 632
(q) 8 514 786 }

(R. 1060) (R. 1062) 6 035 404

RONIS (R. 1060) † 8 512 908

NEIMANN { (p) 8 520 313
(q) 8 535 997 }

(R. 1060) (R. 1062) 6 035 402

(R. 1060) (R. 1062) 6 035 403

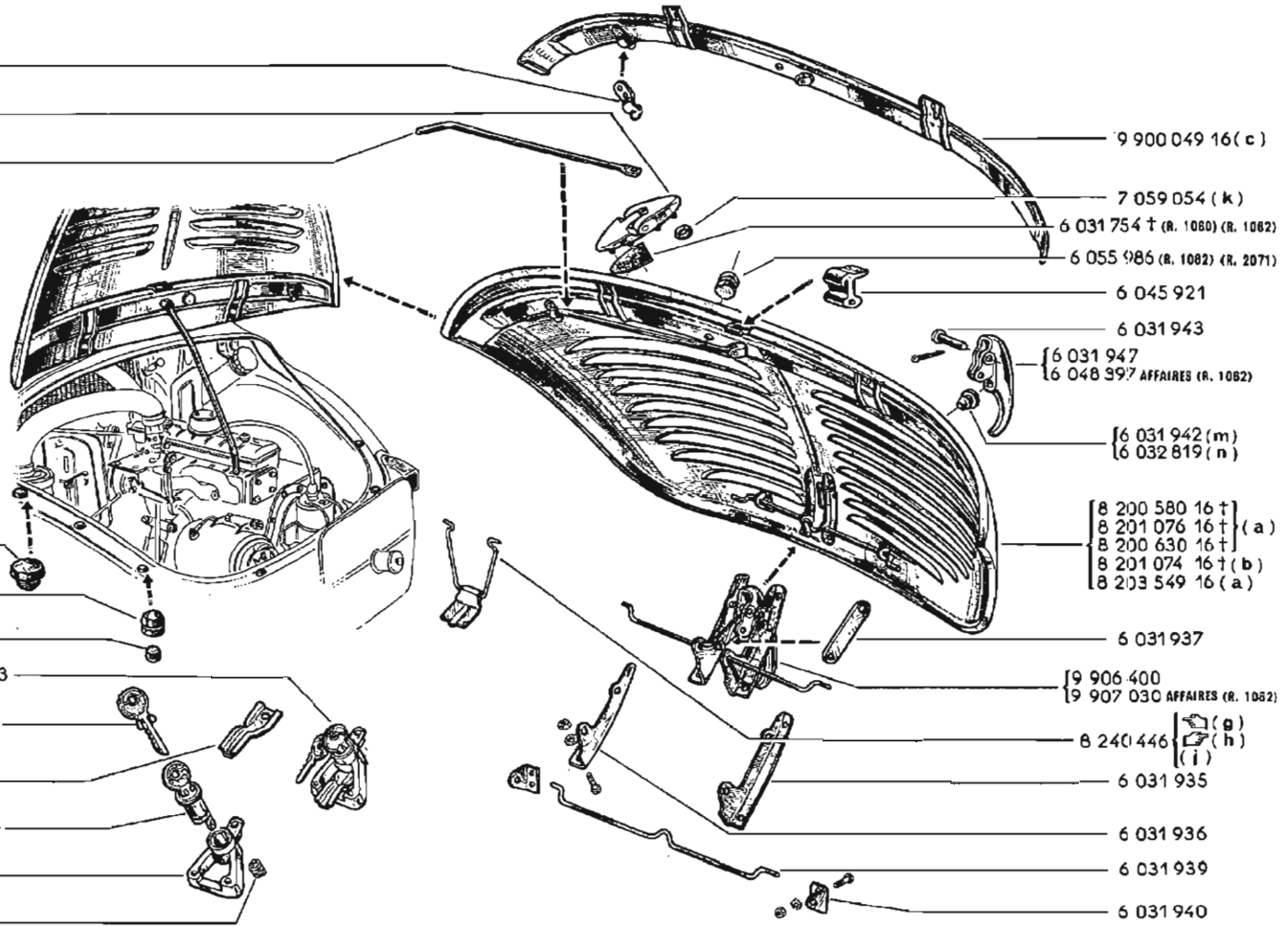

	n°...	n°...	!!!
(a)			34
(b) R.1060			34
R.2070			34
R.2071			34
R.1082	1 VEH	745199	34
(c)			214
(d) R.1060 NORMAL	1 VEH	27735	
R.1060 LUXE	1 VEH	27735	
(e) R.1060 NORMAL	1 VEH	2453	
R.1060 LUXE	1 VEH	2453	
(f) R.1060 NORMAL	79925 VEH	...	
R.1060 LUXE	79925 VEH	...	
R.1082			
R.2071			
R.2070	1 VEH	3892	
R.2070	9126 VEH	...	
(g) R.1060 NORMAL	27736 VEH	...	
R.1060 LUXE	27736 VEH	...	
(h) R.1060 NORMAL	2454 VEH	79924	
R.1060 LUXE	2454 VEH	79924	
(j) R.2070	3893 VEH	9125	
(k) R.1060			
R.2070			
R.2071			
R.1082	1 VEH	730729	
(m) R.1062	1 VEH	745199	
(n) R.1062	745200 VEH	...	
(p) R.1060			
R.1062 SERVICE			
R.1082 GRAND LUXE			
R.1062 SPORT	1 VEH	532892	32
R.1062 TOIT OUVRANT	1 VEH	532892	32
R.1082 DÉCAPOTABLE	1 VEH	532892	32
(q) R.1082 SPORT	532893 VEH	...	32
R.1062 TOIT OUVRANT	532893 VEH	...	32
R.1082 DÉCAPOTABLE	532893 VEH	...	32

32
08-00

34



8525339 -1-
 8525007 -J-
 8513783 -J-

214



6032819 -1-



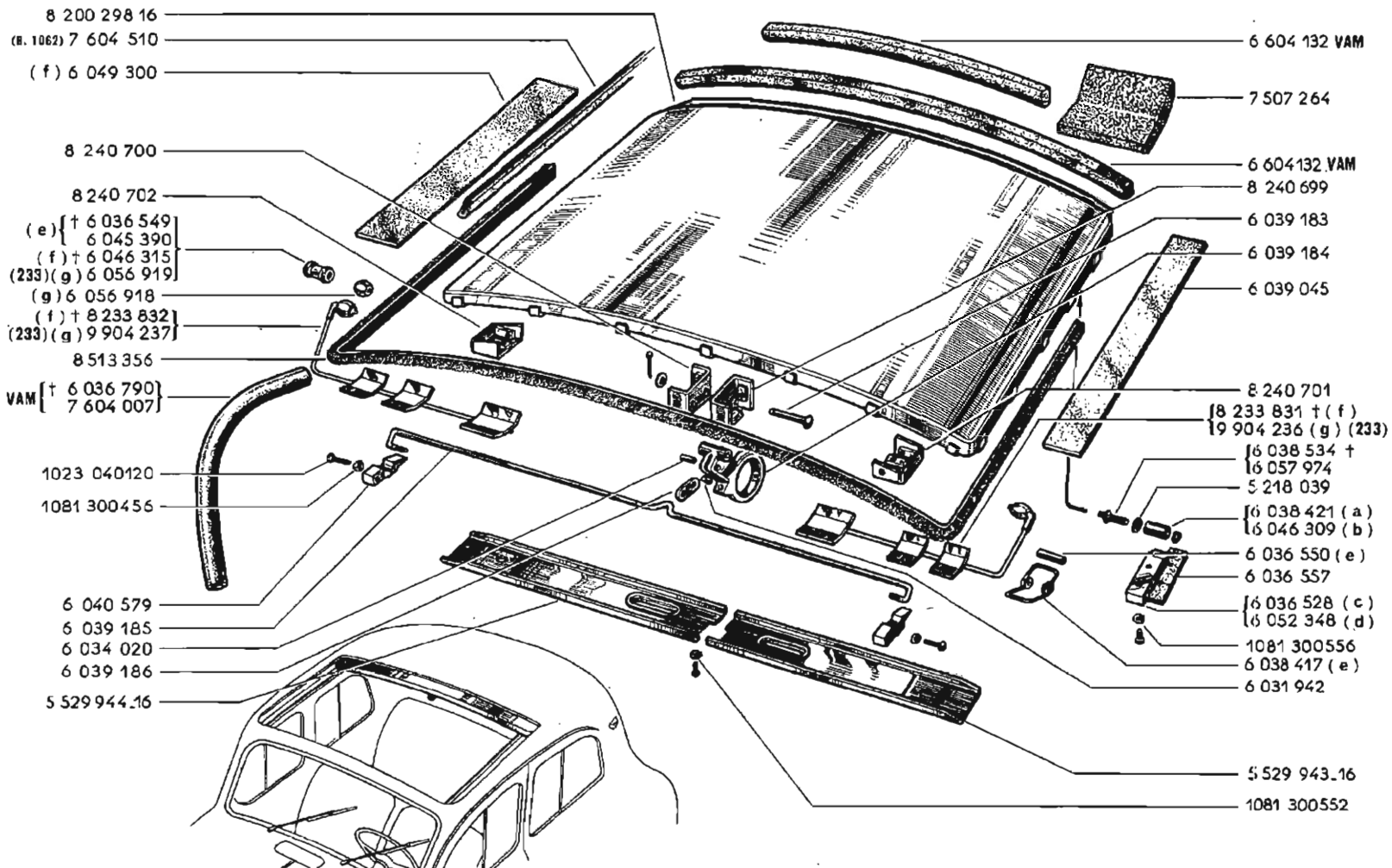

- (a) { R 1060
 R 1062 VEH n° 1 ⇨ VEH n° 798763
- (b) R 1062 VEH n° 798764 ⇨ VEH n° ...
- (c) { R 1060
 R 1062 VEH n° 1 ⇨ VEH n° 365712
- (d) R 1062 VEH n° 365713 ⇨ VEH n° ...

- (e) { R 1060
 R 1062 VEH n° 1 ⇨ VEH n° 327166
- (f) R 1062 VEH n° 327167 ⇨ VEH n° 734319
- (g) R 1062 VEH n° 734320 ⇨ VEH n° ...

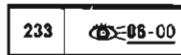

8 221 227_16

8 221 226_16

4 265 074

6 038 739

4 265 108

7 604 292

8 210 684_16

8 210 685_16

9 980 419

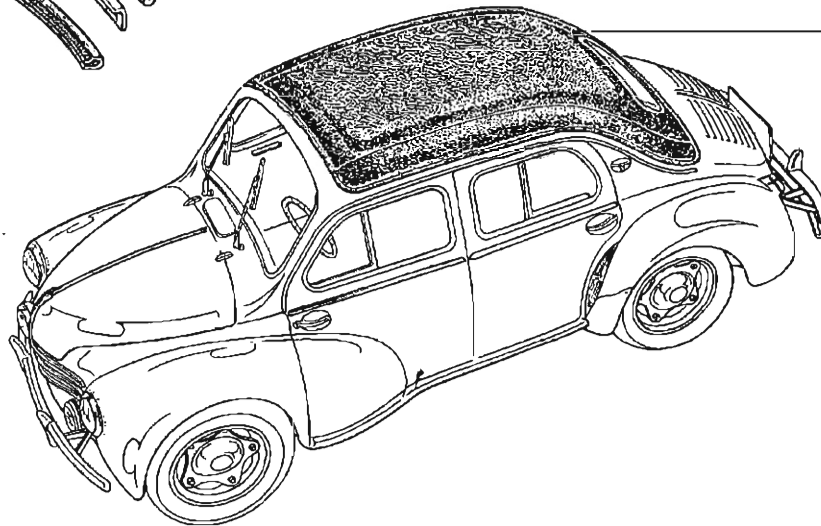

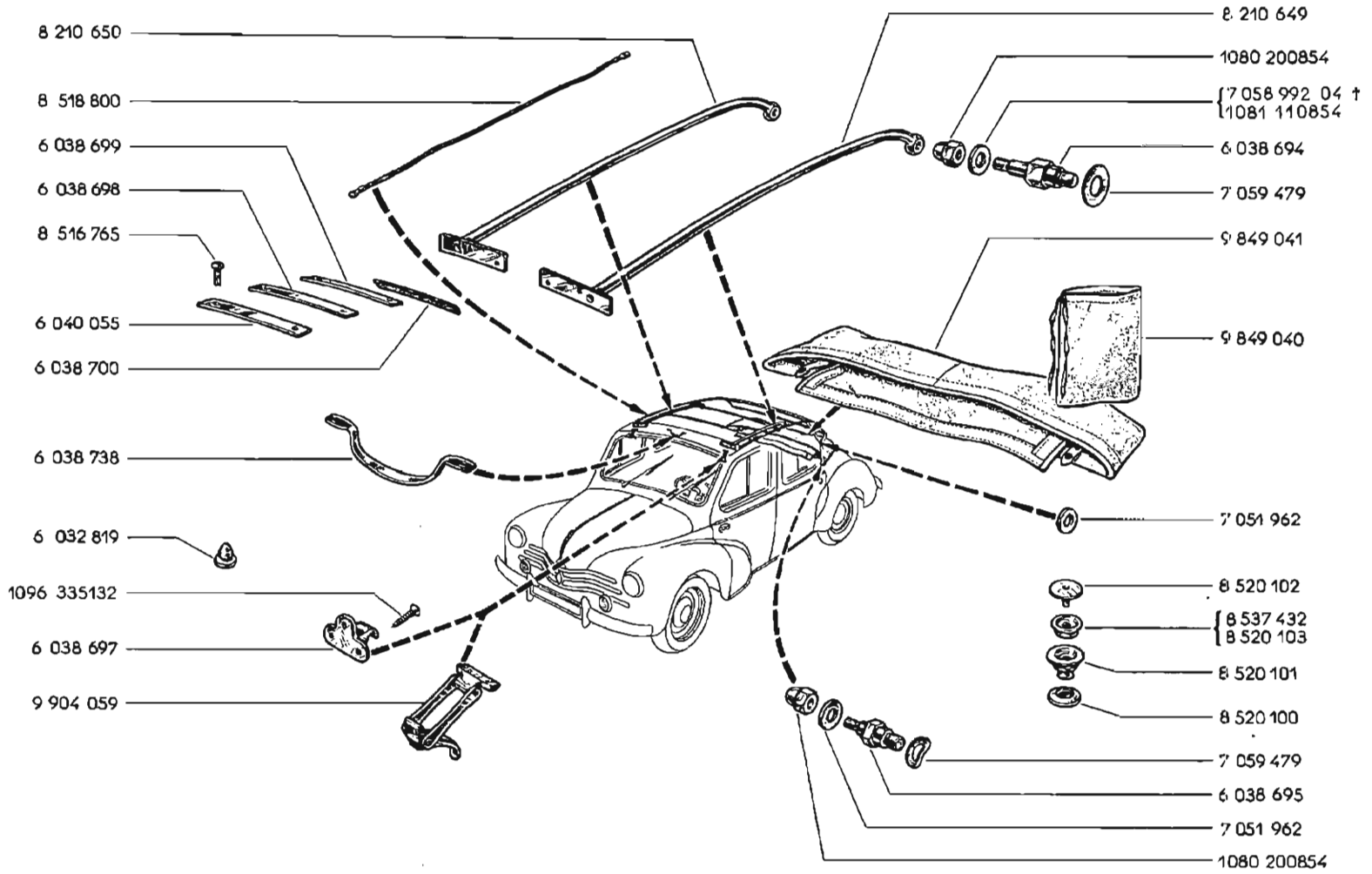

(c) † 9 926 506
(d) † 9 926 407
(e) † 9 926 504

(a) † 9 926 322
(b) † 9 926 323

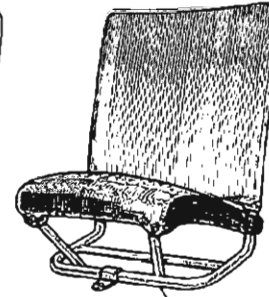
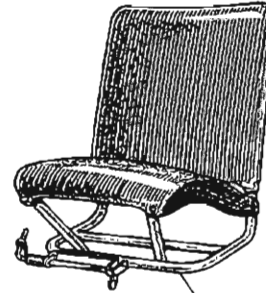
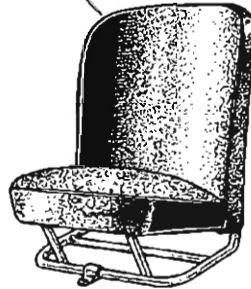
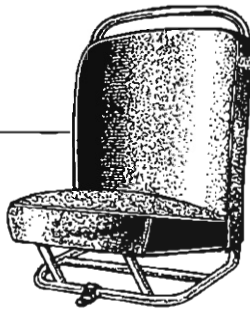

9 926 484 † (R. 1062) AFFAIRES { (f) (g) }

{ 9 981 006 † (h)
9 981 518 † (j)
9 986 014 † (k) } C4 (R. 1062) AFFAIRES
9 986 147

(R 1062 SPORT,
TOIT OUVRANT)

{ (m) † 9 980 998 70
(n) † 9 980 998 61
(p) † 9 980 998 62
(q) † 9 980 998 71
(r) † 9 981 272 11
(s) † 9 981 272 61 } C9
C7 { (r) † 9 981 272 41
(s) 9 981 272 42 }
C8 { (t) † 9 981 272 62
(s) 9 981 272 63 }

{ 9 981 001 † (g)
9 981 002 61 † C9 { (w)
"US" (r) } } DÉCAPOTABLE
9 981 002 62 C8 (s)
9 981 002 71 † (x) } C8 "US"
9 981 002 72 (s) }

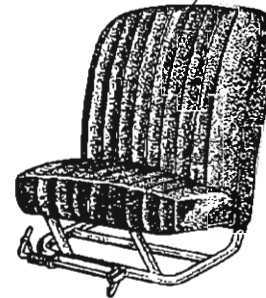
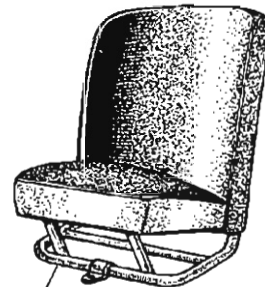
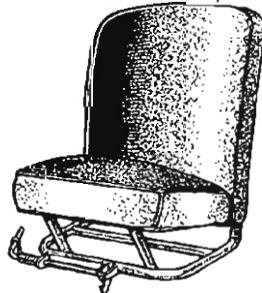

(g) (R 1062 SPORT,
TOIT OUVRANT) † 9 980 981

{ 9 926 306 † (u)
9 926 523 † (v) } DÉCAPOTABLE

C4
C7
C8
C9
①-100-00

	n°...	n°...	!!!
(a) R.1060 NORMAL			
R.1060 LUXE			
R.1060 TOIT OUVRANT			
R.1082 NORMAL	5470 VEH	255066	
R.1082 LUXE	1610 VEH	255066	
R.1082 SERVICE	1610 VEH	255066	
R.1082 AFFAIRES	1610 VEH	255066	
R.1062 TOIT OUVRANT	1610 VEH	255066	
R.2070			
R.2071	546 VEH	...	
(b) R.1060 GD LUXE	125940 VEH	...	186
			187
R.1060 DÉCAPOTABLE	125940 VEH	...	188
			187
R.1060 TOIT OUVRANT	125940 VEH	...	188
			187
R.1062 GRAND LUXE			188
			187
R.1062 TOIT OUVRANT			188
			187
R.1062 DÉCAPOTABLE	1 VEH	299521	188
			187
(c) R.1062 NORMAL	255067 VEH	...	186
			187
R.1062 LUXE	255067 VEH	...	188
			187
R.1062 SERVICE	255067 VEH	...	188
			187
R.1062 AFFAIRES	255067 VEH	...	188
			187
R.2070			
R.2071	546 VEH	...	
(d) R.1062	1 VEH	405209	187
R.1082 SPORT	405601 VEH	406426	
R.1062 TOIT OUVRANT	405601 VEH	406426	

!!!

186	06-00
187	06-00

	n°...	←	n°...	↗	↘	!!!
(e) R.1062	1 VEH		405209			187
R.1082 SPORT	405601 VEH		406426			
R.1082 TOIT OUVRANT	405601 VEH		406426			
(f)	1 VEH		405209			
	405601 VEH		406426			
(g)	405210 VEH		405600			
	406427 VEH		532892	32		
(h)	1 VEH		405209			186
	405210 VEH		405600			
	405601 VEH		406426			186
	406427 VEH		532892	32	32	186
	1 VEH		621704	32		
(j)	1 VEH		812763			
(k)	812764 VEH		...			240
(m)	405210 VEH		405600			186
	406427 VEH		665931	32		186
(n)	405210 VEH		405600			186
						215
	406427 VEH		812763	32		186
						215
(p)	665932 VEH		812763			215
(q)	665932 VEH		...			215
(r)	812764 VEH		869015			
(s)	869016 VEH		...			
(t)	812764 VEH		...			
(u)	299522 VEH		405209			186
	405601 VEH		406426			186
(v)	299522 VEH		405209			187
	405601 VEH		406426			187
(w)	405210 VEH		405600			186
	406427 VEH		532892	32	32	186
	532893 VEH		...	32		186
(x)	532893 VEH		...			

32	⊗ 08-00
----	---------

186	⊗ 08-00
187	⊗ 08-00
215	⊕ 9981034 -f-
240	⊕ 9986018 -f-



(R. 1052) [SPORT, TOIT OUVRANT (e)†9 926 505]
 AFFAIRES [(f)†9 926 483] (g)†9 926 483

[9 981 005 (h)†9 926 483] (j)†9 926 483
 [(k)†9 926 483] (R. 1082) AFFAIRES
 [9 981 517†(m)] C4
 [9 986 013†(n)] C4
 [9 986 146 (p)] C4

(a)†9 926 324
 (b)†9 926 325
 (c)†9 926 507
 (R. 1082) SPORT TOIT OUVRANT (d)†9 926 406

9 926 188†(ae)

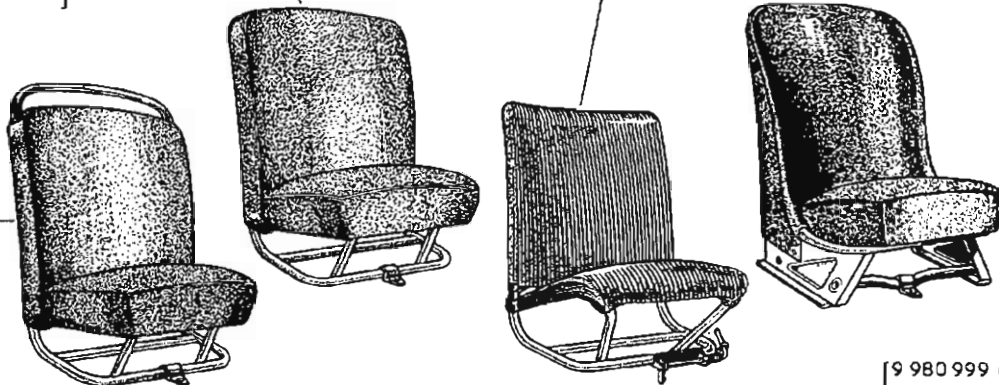

(R. 1082) SPORT C9 (v)†9 980 980 41
 C6-C9 [(w)†9 980 980 72] (p) 9 980 980 73
 C5-C9 (x)†9 980 980 42
 C6-C8 (p) 9 980 980 74
 C5-C7 [(y)†9 980 980 43] (p)†9 980 980 44
 (z)†9 980 980 91
 C7 [(y)†9 981 065 41] (p) 9 981 065 42
 (y) 9 981 065 45
 C9 [(p) 9 981 065 63] (y) 9 981 065 62

[9 980 999 61†CB (ac)†9 926 483] (R. 1082) DÉCAPOTABLE
 [(us)†9 926 483] (w)†9 926 483
 [9 980 999 62†CB (p)†9 926 483] (ad)†9 926 483
 [9 980 999 72 (p)] CB (us)†9 926 483

(R. 1082) SPORT TOIT OUVRANT (q)†9 980 997
 (r)†9 980 980 70
 (s)†9 980 980 61
 C9 (t)†9 980 980 62
 (u)†9 980 980 71
 †(t) [(y)†9 981 065 11] C9†9 981 065 61

[9 926 307†] (aa)†9 926 522†
 [9 981 000†] (ab) (R. 1082) DÉCAPOTABLE

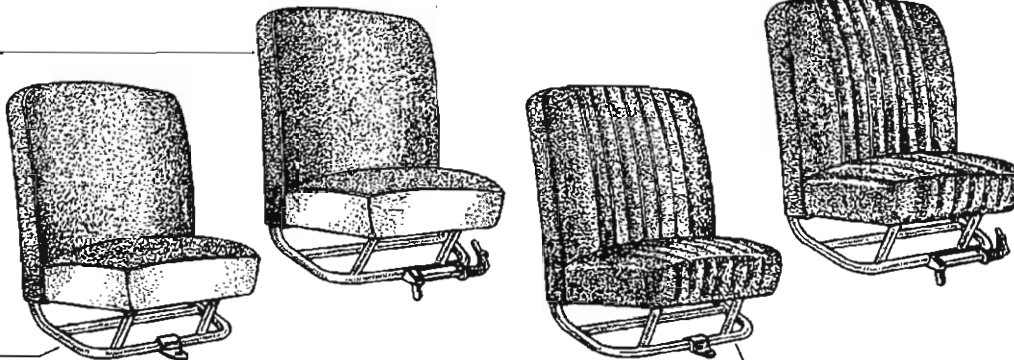

C5
 C7
 C4
 C9
 C6
 C5
 C8
 180-00

	n°...	n°...	!!!
(a) R.1060 NORMAL LUXE TOIT OUVRANT			
R.1062 NORMAL	5470 VEH	255066	
LUXE	1610 VEH	255066	
SERVICE	1610 VEH	255066	
AFFAIRES	1610 VEH	255066	
TOIT OUVRANT	1610 VEH	255066	
R.2070			
R.2071	546 VEH	...	
(b) R.1060 GD LUXE	125940 VEH	...	188
			188
R.1060 DÉCAPOTABLE	125940 VEH	...	188
			188
R.1060 TOIT OUVRANT	125940 VEH	...	188
			188
R.1082 GRAND LUXE			188
			188
R.1082 TOIT OUVRANT			188
			188
R.1082 DÉCAPOTABLE	1 VEH	299521	188
			188
(c) R.1062 NORMAL	255067 VEH	...	188
			188
R.1062 LUXE	255067 VEH	...	188
			188
R.1062 SERVICE	255067 VEH	...	188
			188
R.1062 AFFAIRES	255067 VEH	...	188
			188
R.2070			188
			188
R.2071	546 VEH	...	188
			188
(d)	1 VEH	405209	188
			188
(e)	1 VEH	405209	188
	405601 VEH	406426	188
			188
(f)	1 VEH	405209	
	405601 VEH	406426	

!!!

188	06-00
188	06-00



	n°...	→	n°...	!!!	!!!
(g)	405210 VEH		405600		
	406427 VEH		532892	32	
(h)	1 VEH		406426		188
	1 VEH		621704	32	188
(j)	406427 VEH		532892		188
(k)	406427 VEH		532892	32	
(m)	1 VEH		812763		
(n)	812764 VEH		869015		242
(p)	869016 VEH		...		
(q)	405210 VEH		405600		188
	406427 VEH		532892	32	
(r)	405210 VEH		405600		
	406427 VEH		665931	32	
(s)	405210 VEH		405600		188
	406427 VEH		812763	32	216
				32	188
					216
(t)	665932 VEH		812763		216
(u)	665932 VEH		...		216
(v)	1 VEH		812763		216
(w)	812764 VEH		869015		
(x)	812764 VEH		869015		243
(y)	812764 VEH		...		
(z)	812764 VEH		1-12-1958		216
(aa)	299522 VEH		405209		188
	405601 VEH		405426		188
(ab)	405210 VEH		405600		
	406427 VEH		532892	32	188
(ac)	405210 VEH		405600		188
	406427 VEH		532892	32	188
	532893 VEH		...	32	188
(ad)	532893 VEH		...		
(ae)	R.1080 NORMAL				143
	R.1080 LUXE				143
	R.1082 LUXE				
	R.1082 SERVICE				
	R.1082 AFFAIRES				
	R.1082 TOIT OUVRANT				
	NORMAL	1 VEH	5469		143
	R.2070				
	R.2071	1 VEH	545		

32	!!!	08-00
----	-----	-------

143	!!!	08-00
186	!!!	08-00
188	!!!	08-00
216	+	9981003 -1-
242	+	9986017 -1-
243	+	9981003 -1-



(k) +9 981 008
(m) }
(n) 9 986 018
(m) }
(p) 9 986 158

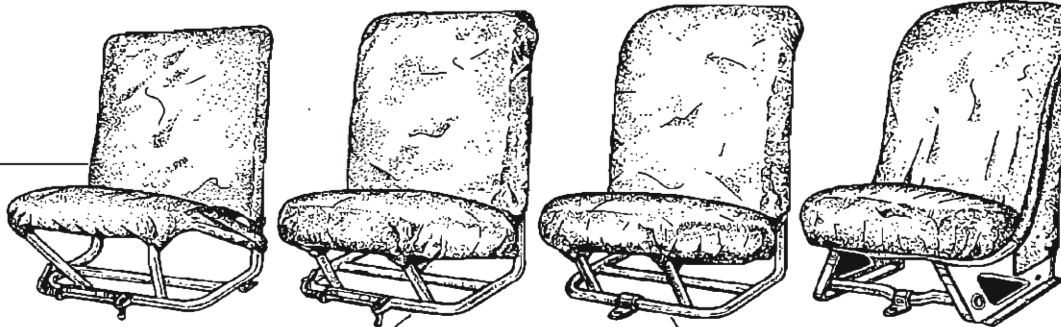

{ 9 926 159 † (a)
9 926 287 (b) (R.1060)

(R.1082 DÉCAPOTABLE) { (h) } 9 981 004
(j)

(R.1062 DÉCAPOTABLE) { (h) } 9 981 003
(j)

{ 9 926 320 † (c)
9 926 308 † (d)
9 926 405 † (e)
9 926 508 † (f)
9 926 488 † (g)

(R.1062 AFFAIRES) { (h) } +9 981 007
(k) }
(m) } 9 986 017
(n) }
(p) 9 986 157

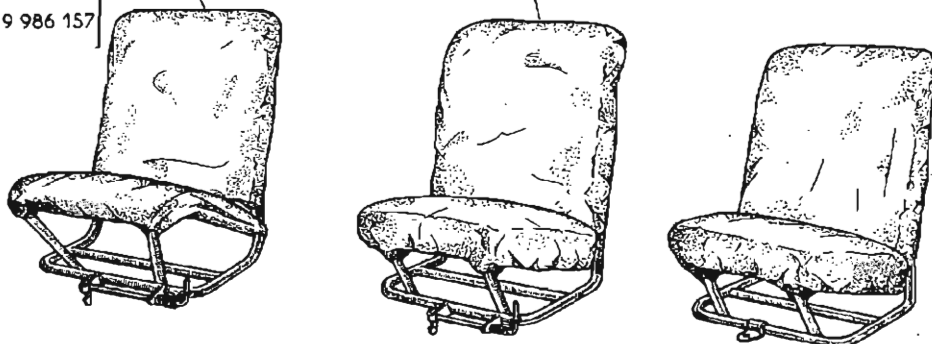

{ 9 926 321 † (c)
9 926 309 † (d)
9 926 404 † (e)
9 926 509 † (f)
9 926 486 † (g)

	n°...	n°...	!!!
(a) R.1060 NORMAL			144
R.1060 LUXE			144
R.1062 LUXE	1 VEH	1609	144
R.1062 SERVICE	1 VEH	1609	144
R.1062 TOIT OUVRANT	1 VEH	1609	144
R.1062 NORMAL	1 VEH	5459	144
R.2070			
R.2071	1 VEH	545	
(b) GRAND LUXE	1 VEH	125939	144
TOIT OUVRANT	1 VEH	125939	144
(c) R.1060 NORMAL			
R.1060 LUXE			
R.1060 TOIT OUVRANT			
R.1062 NORMAL	5470 VEH	255066	
R.1062 LUXE	1610 VEH	255066	
R.1062 SERVICE	1610 VEH	255066	
R.1062 AFFAIRES	1610 VEH	255066	
R.1062 TOIT OUVRANT	1610 VEH	255066	
R.2070			
R.2071	545 VEH	...	
(d) R.1060 GD LUXE	125940 VEH	...	
R.1060 TOIT OUVRANT	125940 VEH	...	
R.1060 DÉCAPOTABLE	125940 VEH	...	
R.1062 GRAND LUXE			
R.1062 TOIT OUVRANT			
R.1062 DÉCAPOTABLE	1 VEH	299521	

!!!

144
08-00



	n°...	↳	n°...	↘	↙	!!!
(e) R.1062 SPORT	1 VEH		255066			
(f) R.1062 GD LUXE	125940 VEH		...			
R.1062 TOIT OUVRANT	125940 VEH		...			
R.1062 DÉCAPOTABLE	125940 VEH		...			
NORMAL	255067 VEH		...			
SPORT	255067 VEH		405209			
SPORT	405601 VEH		406426			
LUXE	255067 VEH		...			186
						187
SERVICE	255067 VEH		...			186
						187
AFFAIRES	255067 VEH		...			188
						187
R.2070						
R.2071	546 VEH		...			
(g) R.1062 AFFAIRES	1 VEH		405209			
R.1062 AFFAIRES	405601 VEH		406426			
(h)	405210 VEH		405600			
	406427 VEH		532892		32	
(j)	532893 VEH		...	32		
(k)	1 VEH		405209			186
	405601 VEH		406426			186
	532893 VEH		812763	32		
(m)	405210 VEH		405600			
	406427 VEH		532892		32	
(n)	1 VEH		405209			
	405601 VEH		406426			
	532893 VEH		812763	32		
	812764 VEH		869015			
(p)	869016 VEH		...			

32

YXXX
00000

08-00

!!!

186

08-00

187

08-00



(R. 1062 SPORT, DÉCAPOTABLE) TOIT OUVRANT } † 8 526 125

(k) † 8 526 511
(m) 8 527 181
(n) † 8 525 707

(f) † 8 200 598
(g) 8 200 554
(h) † 8 525 767

8 240 394

(d) (e) 6 033 617 16

(R. 1062 SPORT, TOIT OUVRANT DÉCAPOTABLE) (j)

† 8 526 126
(k) † 8 526 568
(m) 8 527 182
(n) † 8 525 708

(f) † 8 200 597
(g) † 8 200 553
(h) † 8 525 766
(b) 9 926 158
(c) 9 926 289

(R. 1082 AFFAIRES)

(p) † 8 526 128
(q) † 8 526 567
† 8 526 884
(r) † 8 527 142
(s) † 8 527 480
(t) 8 527 697

8 541 076

(2)

(R. 1062 AFFAIRES)

(p) † 8 526 127
(q) † 8 526 566
† 8 526 883
(r) 8 527 141
(s) † 8 527 479
(t) 8 527 696

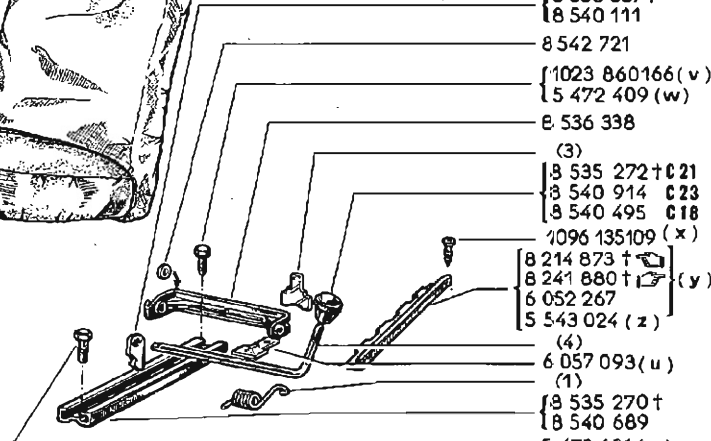
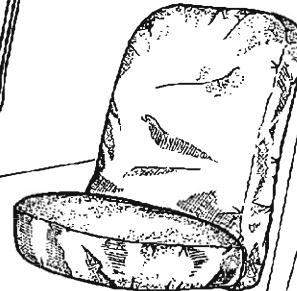
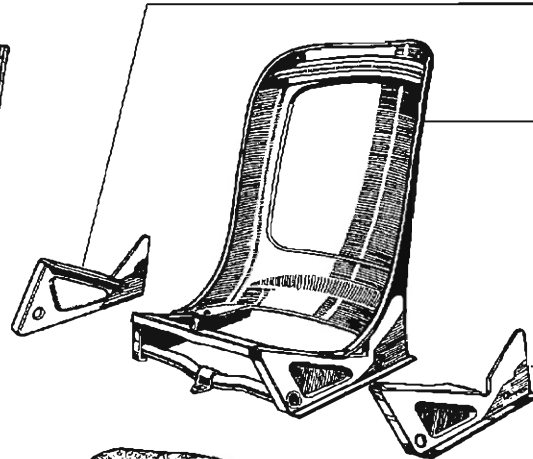
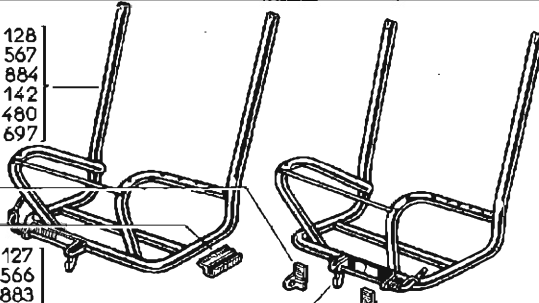
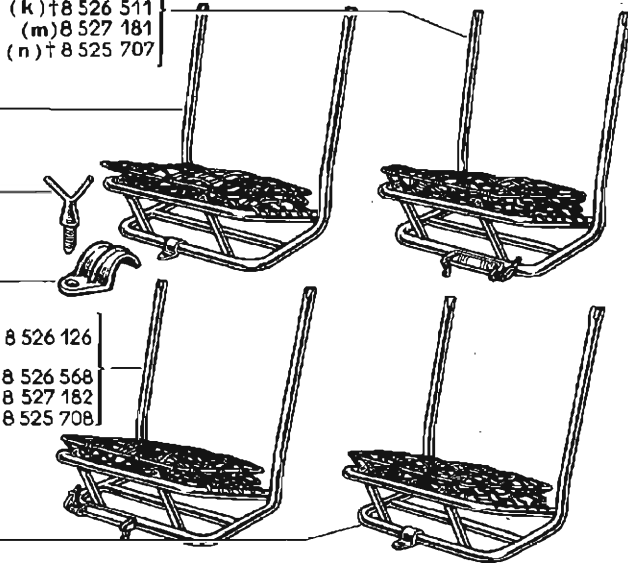

2 554 094 16 (a)

8 200 350 16 (a)

2 554 093 16 (a)

9 926 155 (b)

9 926 286 (c)

8 536 337 †

8 540 111

8 542 721

1023 860 166 (v)

5 472 409 (w)

8 536 338

(3)

8 535 272 † C 21

8 540 914 C 23

8 540 495 C 18

1096 135 109 (x)

8 214 873 † (y)

8 241 880 † (y)

6 052 267

5 543 024 (z)

(4)

6 057 093 (u)

(1)

8 535 270 †

8 540 689

5 472 681 (w)

8 540 107

	8526125 8526127	8526126 8526128	8526511 8526566 8526883	8526567 8526568 8526884	8527141 8527181	8527142 8527182 8527479 8527480	8527696
(1)	8535271	8539308	8536428	8536414	8540110	8541035	8540110
(2)			8536335	8536335	8536335	8536335	8544218
(3)			8536336	8536336	8540108	8541077	8540108
(4)			8540109	8540109	8540109	8540109	8544137

	n°...	n°...	!!!
(a) R.1060 NORMAL LUXE			
GRAND LUXE	1 VEH	125939	
TOIT OUVRANT	1 VEH	125939	
R.1062 NORMAL LUXE	1 VEH	5469	
SERVICE AFFAIRES	1 VEH	1609	
TOIT OUVRANT	1 VEH	1609	
R.2070			
R.2071	1 VEH	545	
(b) R.1060 NORMAL LUXE			
R.1062 NORMAL LUXE	1 VEH	5469	
SERVICE AFFAIRES	1 VEH	1609	
TOIT OUVRANT	1 VEH	1609	
R.2070			
R.2071	1 VEH	545	
(c) R.1060 GD LUXE	1 VEH	125939	
R.1060 TOIT OUVRANT	1 VEH	125939	
(d) R.1060	1 VEH	47561	
R.2070	1 VEH	5388	
(e) R.1060	1 VEH	4142	
R.2070	1 VEH	22	
(f) R.1060 NORMAL LUXE			
TOIT OUVRANT			
R.1062 NORMAL SPORT	5470 VEH	255066	
TOIT OUVRANT LUXE	1 VEH	255066	
SERVICE AFFAIRES	1 VEH	255066	
R.2070	1610 VEH	255066	
R.2071	1610 VEH	255066	
	1610 VEH	255066	
	546 VEH	...	
(g) R.1060 GD LUXE	125940 VEH	...	
R.1060 DÉCAPOTABLE	125940 VEH	...	
R.1060 TOIT OUVRANT	125940 VEH	...	
R.1062 GRAND LUXE			
R.1062 TOIT OUVRANT DÉCAPOTABLE	1 VEH	299521	
(h) R.1060 DÉCAPOT.	125940 VEH	...	
R.1060 GRAND LUXE	125940 VEH	...	
R.1060 TOIT OUVRANT	125940 VEH	...	

	n°...	VEH	n°...	32	!!!
(h) R.1062 NORMAL	255067	VEH	532892	32	
LUXE	255067	VEH	532892	32	
SPORT	255067	VEH	532892	32	
AFFAIRES	255067	VEH	532892	32	
TOIT OUVRANT	255067	VEH	532892	32	
GRAND LUXE	1	VEH	532892	32	
DÉCAPOTABLE	299522	VEH	532892	32	
R.2070					
R.2071	546	VEH	...		
(j)	406427	VEH	532892	32	
(k) R.1060 GD LUXE	125940	VEH	...		186
R.1060 TOIT OUVRANT	125940	VEH	...		186
R.1060 DÉCAPOTABLE	125940	VEH	...		186
R.1062 SPORT	405210	VEH	405600		
R.1062 SPORT	406427	VEH	...	32	186
R.1062 TOIT OUVRANT	405210	VEH	405600		
R.1062 TOIT OUVRANT	406427	VEH	...	32	186
R.1062 DÉCAPOTABLE	405210	VEH	405600		
R.1062 DÉCAPOTABLE	406427	VEH	...	32	186
LUXE	1	VEH	532892	32	186
AFFAIRES	1	VEH	532892	32	186
SPORT	1	VEH	532892	32	186
NORMAL	1	VEH	532892	32	186
TOIT OUVRANT	1	VEH	532892	32	186
GRAND LUXE	1	VEH	532892	32	186
DÉCAPOTABLE	1	VEH	532892	32	186
R.2070					
R.2071					
(m)					224
(n) R.1062 AFFAIRES	1	VEH	405209		
R.1062 AFFAIRES	405601	VEH	406426		
(p)	405210	VEH	405600		186
	406427	VEH	532892	32	186
(q)	1	VEH	405209		186
	405601	VEH	406426		186
	532893	VEH	593090	32	186
(r)	1	VEH	812763		224
(s)	812764	VEH	869015		
(t)	869016	VEH	...		
(u) R.1062	532893	VEH	...		
(v) R.1062	1	VEH	587001		
(w) R.1062	587002	VEH	...		
(x) R.1062	1	VEH	440701		
(y) R.1062	405210	VEH	405600		
R.1062	406427	VEH	440701		
(z) R.1062	405210	VEH	532892	32	32
R.1062	532893	VEH	...	32	

XXXX
00000

32	08-00
----	-------

!!!

186	08-00
224	08-00



(g) † 9 980 983 70
 SPORT TOIT OUVRANT { (q) † 9 980 983 61
 (r) † 9 980 983 62
 (s) † 9 980 983 41
 C6-C9 (t) † 9 980 983 72
 C5-C9 † 9 980 983 42
 C5-C7 (t) † 9 980 983 43
 (v) † 9 980 983 91
 (R.1062) C6-C9 † 9 980 983 73
 (b) C6-C8 † 9 980 983 74
 C5-C7 † 9 980 983 44
 SPORT (q) † 9 981 068 11
 TOIT OUVRANT † 9 981 068 61
 (t) † 9 981 068 41
 SPORT † 9 981 068 62
 (b) † 9 981 068 42
 † 9 981 068 63

C9 (d) † 9 980 982 41
 C6 (e) † 9 980 982 72
 C9 (b) † 9 980 982 73
 SPORT C5-C9 (e) † 9 980 982 42
 C6-C8 (b) † 9 980 982 74
 C5 (e) † 9 980 982 43
 C7 (b) † 9 980 982 44
 (f) † 9 980 982 91
 (g) † 9 980 982 70
 (R.1062) TOIT OUVRANT (h) † 9 980 982 61
 C9 † 9 980 982 62
 (i) † 9 980 982 71
 TOIT OUVRANT (h) † 9 981 067 11
 C9 † 9 981 067 61
 (e) † 9 981 067 41
 SPORT (b) † 9 981 067 42
 (c) † 9 981 067 62
 (b) † 9 981 067 63

(z) 5 526 068
 (aa) 5 534 775
 (p) 3 533 406

(R.1060) 9 926 310
 DÉCAPOTABLE (R.1062) { (k) C9 † 9 981 009 61
 (m) C8 † 9 981 009 71
 (b) C8 9 981 009 72 }
 (R.1060) 9 926 312
 DÉCAPOTABLE (R.1062) { (w) C9 9 981 010 61
 (x) C9 9 981 010 61 }
 (y) C8 9 981 010 71
 (b) C9 9 981 010 62
 C8 9 981 010 72

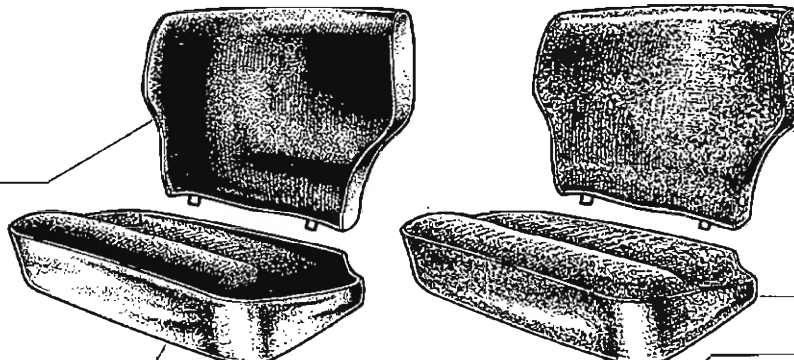

9 981 520 † (m) (R.1062 AFFAIRES)
 9 986 149 (b) (R.1062 AFFAIRES)
 9 926 282 (R.1060 GRAND LUXE TOIT OUVRANT)

9 981 519 † (a) AFFAIRES (R.1062)
 9 986 148 (b) AFFAIRES (R.1062)
 9 980 663 † (c) SPORT, TOIT OUVRANT (R.1062)

5 526 069 (ab)
 4 271 853 (p)

9 926 156 { (R.1060 NORMAL, LUXE, TOIT OUVRANT)
 (R.1062 NORMAL, LUXE, AFFAIRES, TOIT OUVRANT) }
 9 926 487 (SERVICE AFFAIRES 1952) (R.1062)
 9 980 673 (AFFAIRES 1954) (R.1062)
 9 926 311 { (R.1060)
 (n) } DÉCAPOTABLE
 9 980 669 (p)
 9 926 283 { (R.1060) } GRAND LUXE, TOIT OUVRANT
 (n)
 9 980 459 (n)
 9 980 665 { (p) } SPORT, TOIT OUVRANT
 9 980 722

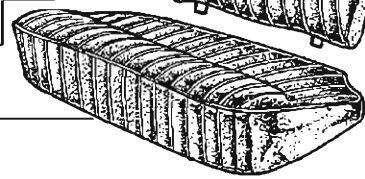
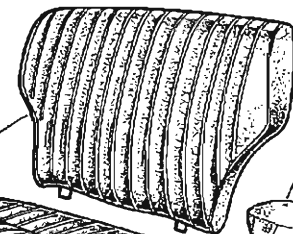
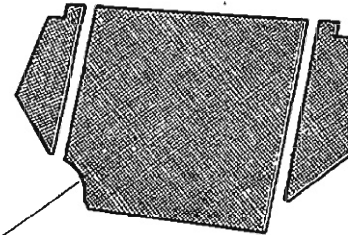

9 926 157 { NORMAL, LUXE, TOIT OUVRANT
 (R.1062 SERVICE AFFAIRES 1953) }
 9 926 489 SERVICE AFFAIRES 1952 (R.1062)
 9 980 674 SERVICE AFFAIRES 1954 (R.1062)
 9 926 313 { (R.1060)
 (n) } DÉCAPOTABLE
 9 980 670 (p)
 9 926 281 GRAND LUXE, TOIT OUVRANT (R.1060)
 (n)
 9 980 480 (n) SPORT (R.1062)
 9 980 666 (b) SPORT, TOIT OUVRANT (R.1062)

C5
 C6
 C9
 C8
 C7

≤100-00

	n°...	n°...	!!!
(a)	1 VEH	869015	
(b)	869016 VEH	...	
(c)	283716 VEH 405601 VEH	405209 406426	
(d)	1 VEH	812763	217
(e)	812764 VEH	869015	244
(f)	812764 VEH	1-12-1958	217
(g)	405210 VEH 406427 VEH	405600 665931	219 219
(h)	665932 VEH	812763	217
(j)	665932 VEH	...	217
(k)	405210 VEH 406427 VEH 812764 VEH	405600 869015 ...	219
(m)	532893 VEH	869015	219
(n) R.1062	1 VEH	283715	
(p) R.1062	283716 VEH	...	
(q)	665932 VEH	812763	218
(r)	665932 VEH	...	218
(s)	1 VEH	812763	218
(t)	812764 VEH	869015	
(u)	812764 VEH	869015	245
(v)	812764 VEH	...	218
(w)	405210 VEH 406427 VEH	405600 869015	
(x)	812764 VEH	...	
(y)	532893 VEH	869015	
(z) R.1060 R.2070 R.1062	1 VEH	134817	
(aa) R.1062	134818 VEH	283715	
(ab) R.1060 R.1062	1 VEH	283715	

!!!		
217	☞	9980722 - 1 -
218	☞	9980666 - 1 -
219		☞ 06-00
244	☞	9980722 - 1 -
245	☞	9980666 - 1 -



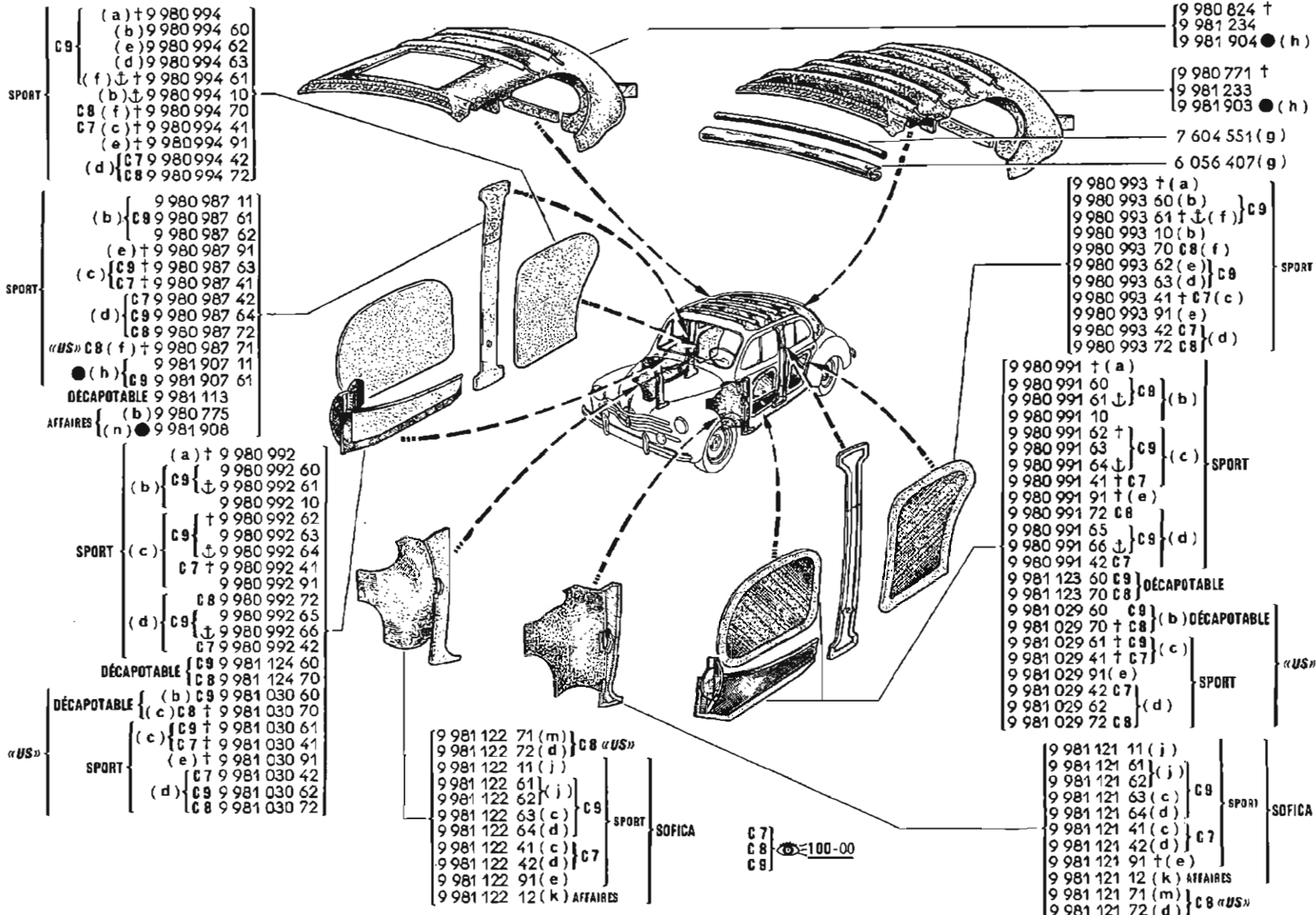

	n°...	⇒	n°...	↙	↘	!!!
(a)	1	VEH	665931			
(b)	1	VEH	812763			
(c)	812764	VEH	869015			
(d)	869016	VEH	...			
(e)	812764	VEH	...			
(f)	1	VEH	869015			
(g)	531953	VEH	532000			
	532651	VEH	532818			
	532893	VEH	...			
(h)	734971	VEH	...			
(j)	754870	VEH	812763			220
(k)	754832	VEH	...			
(m)	754870	VEH	869015			220
(n)	734971	VEH	812763			

!!!

220	06-00
-----	-------



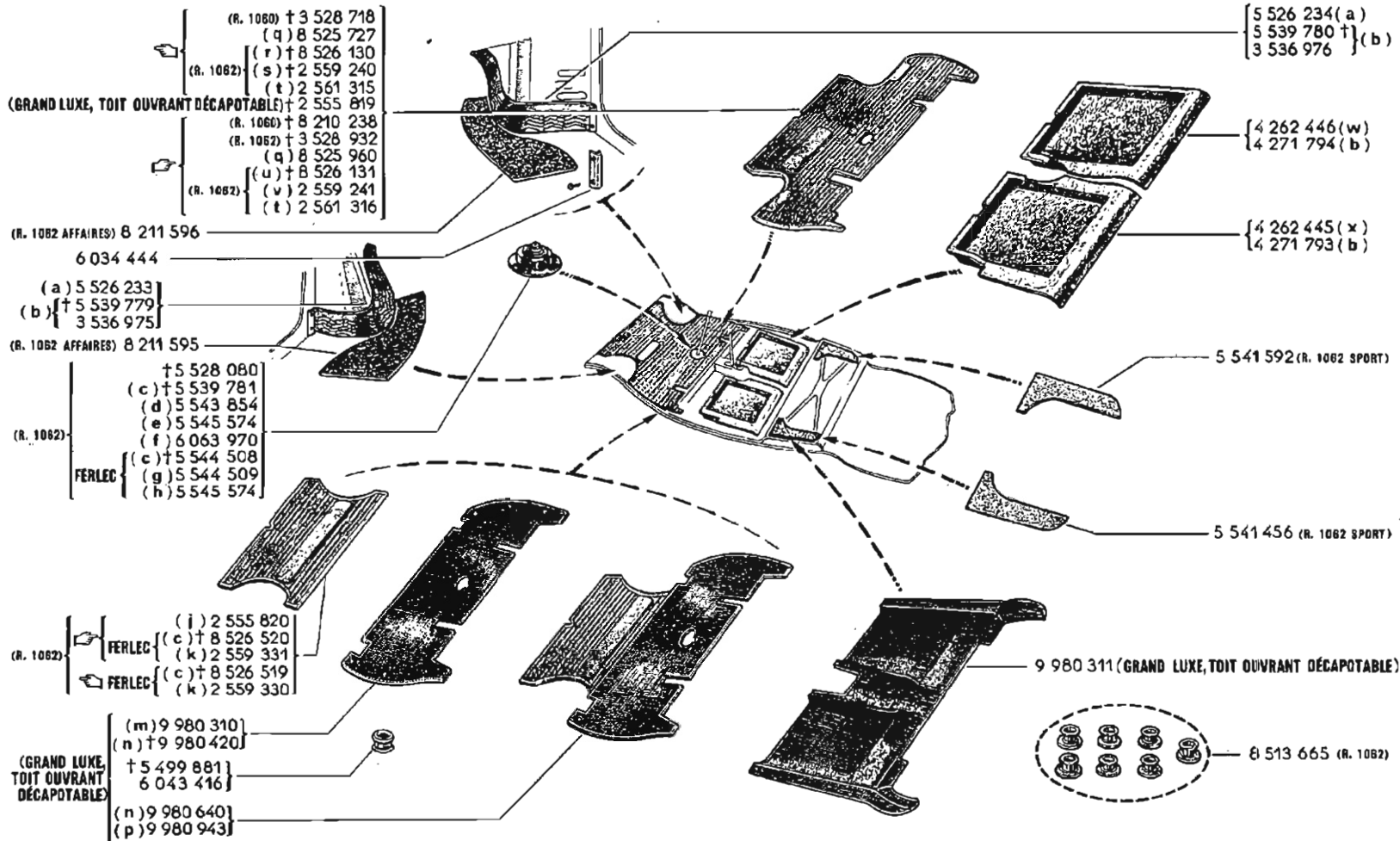

	n°...	n°...	!!!
(a) R.1060 R.2070 R.1062 R.2071	1 VEH 1 VEH	313822 4240	
(b) R.1062 R.2071	313823 VEH 4241 VEH	
(c)	1 VEH	532892	32
(d)	532893 VEH	715183	32
(e)	715184 VEH	812763	
(f)	812764 VEH	...	
(g)	532893 VEH	713663	32
(h)	713664 VEH	812763	
(j) GRAND LUXE TOIT OUVRANT DECAPOTABLE	48798 VEH 48798 VEH 48798 VEH	
(k)	532893 VEH	...	32
(m) R.1060 R.1062	1 VEH	48797	
(n) R.1062	48798 VEH	283715	
(p) R.1062	283716 VEH	...	
(q) R.1060 R.1062 R.1062 R.2070 R.2071	1 VEH 405601 VEH	405209 406426	
(r)	405210 VEH 406427 VEH	405600 532892	32
(s)	532893 VEH	841460	32
(t)	841461 VEH	...	
(u)	405210 VEH	405600	
(v)	406427 VEH 532893 VEH	532892 841460	32
(w) R.1060 R.1062 R.2070 R.2071	1 VEH 1 VEH	313822 4240	145
(x) R.1060 R.1062 R.2070 R.2071	1 VEH	313822	35

32

DB-00

!!!

35	4282446 -1-
145	4282445 -1-



85.01

A P.R. 685
(R. 1082) B 335 021

85.01

A P.R. 685

(R. 1082) SPORT (a) 8 526 642

1098 335381

(R. 1082) SPORT (a) 6 058 904

(R. 1082) SPORT
(b) † 8 526 863
(c) 8 527 003
● C18 B 527 474
C11 B 527 475

(R. 1060) (R. 1082) 8 513 739

(k) } (R. 1060) LUXE 8 513 165
(m) }

(R. 2070) (R. 2071) 8 544 220

(R. 2070) (R. 2071) 8 512 796

(d) (R. 1082) 8 518 962

(R. 1080) (R. 1062) 9 922 018

[8 230 577
8 234 930 (R. 1082) TOIT OUVRANT (e)
8 231 512] TOIT OUVRANT DÉCAPOTABLE
SPORT TOIT OUVRANT (R. 1082) (f)

6 033 647

[1098 342324 DÉCAPOTABLE
1098 339329

8 526 164 (g) (R. 1082) SPORT TOIT OUVRANT

[8 519 609†
8 522 949† (h)] (R. 1082)
8 544 219

8 512 177

8 511 394

7 604 318

8 521 590 (R. 1082)

8 524 557† (R. 1082)

[7 058 491†
7 059 139] NORMAL
7 059 203†
7 059 849 04†
7 061 327†
1061 040209

[9 945 010 (R. 1060) (R. 1082) NORMAL
8 513 688 (R. 1060) (R. 1062)

5 540 844 (j)

6 057 761 (R. 1082)



XXXX
00000

32	08-00
----	-------

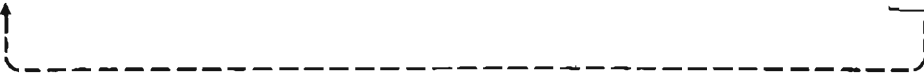
	XXXX 00000	!!!
	n°...	n°...
(a)	680247 VEH ...	
(b)	680247 VEH 717284	
(c)	717285 VEH ...	
(d)	532893 VEH ...	32
(e)	405210 VEH 405600 406427 VEH 532892	32
(f)	1 VEH 406426 406427 VEH 532892	32
(g)	405210 VEH 405600 406427 VEH 532892 532893 VEH 680246	32
(h)	232242 VEH ...	
(j)	R.1060 R.2070 R.2071 R.1062 R.1062	
	1 VEH 405209 405601 VEH 406426	
(k)	1 VEH 33703	
(m)	1 VEH 3730	

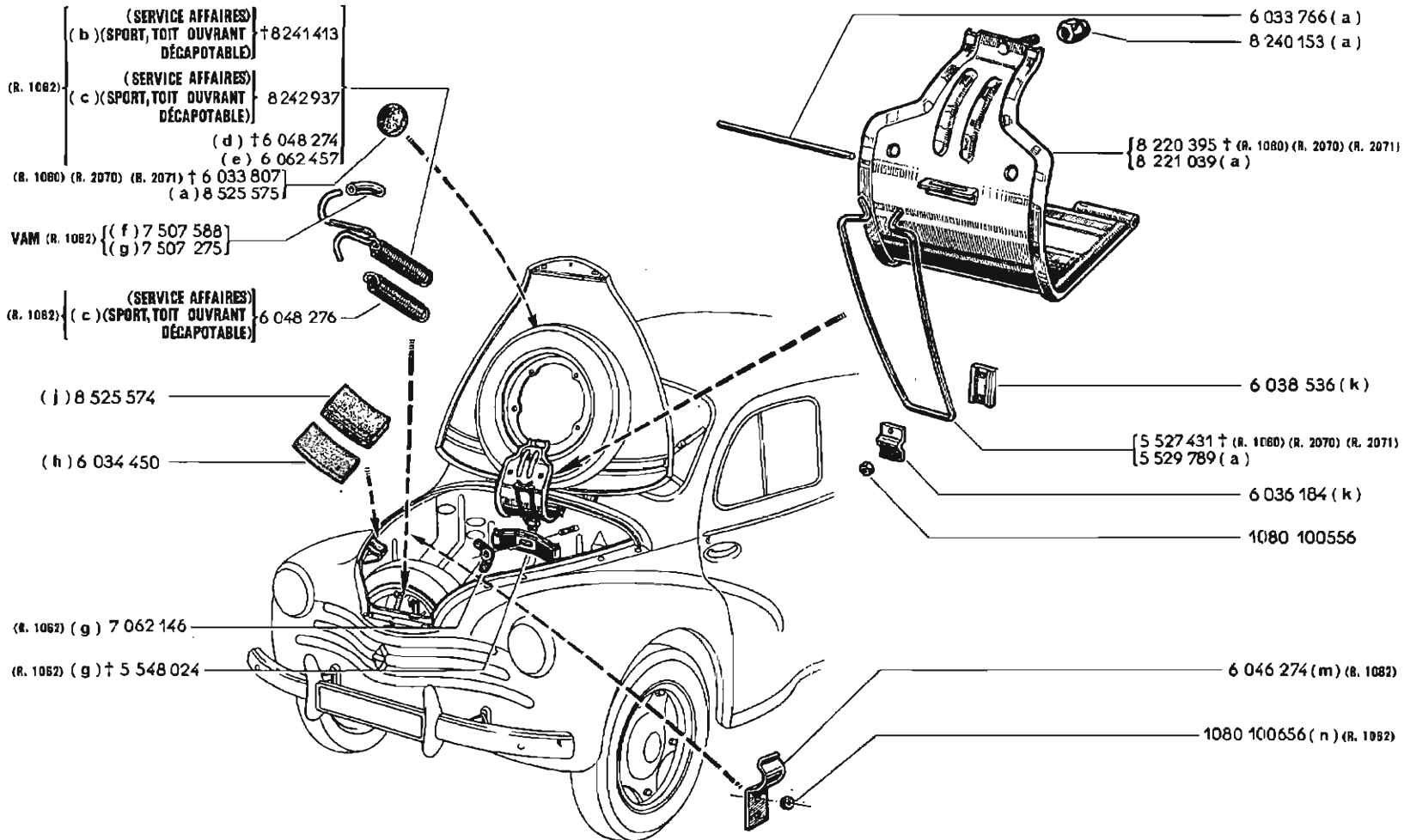



75	 08-00
83	 08-00

XXXX
00000

	n°...	n°...	!!!
(a) R.1080 R.2070 R.2071 R.1062	1 VEH 283715	283715	
(b)	283716 VEH	734971	
(c)	283716 VEH	...	
(d)	1 VEH	748117	
(e)	748118 VEH	...	
(f)	1 VEH	748117	83
(g)	748118 VEH	...	83
(h) R.1060 R.2070	1 VEH 1 VEH	43500 5380	
(j) R.1060 R.1082 R.2070 R.2071	1 VEH 5381 VEH	283715 ...	
(k) R.1060 R.1062 R.2070 R.2071	1 VEH 8464 VEH	283715 ...	
(m)	335623 VEH	748117	75 83
(n)	335623 VEH	748117	83

XXXX
00000

!!!



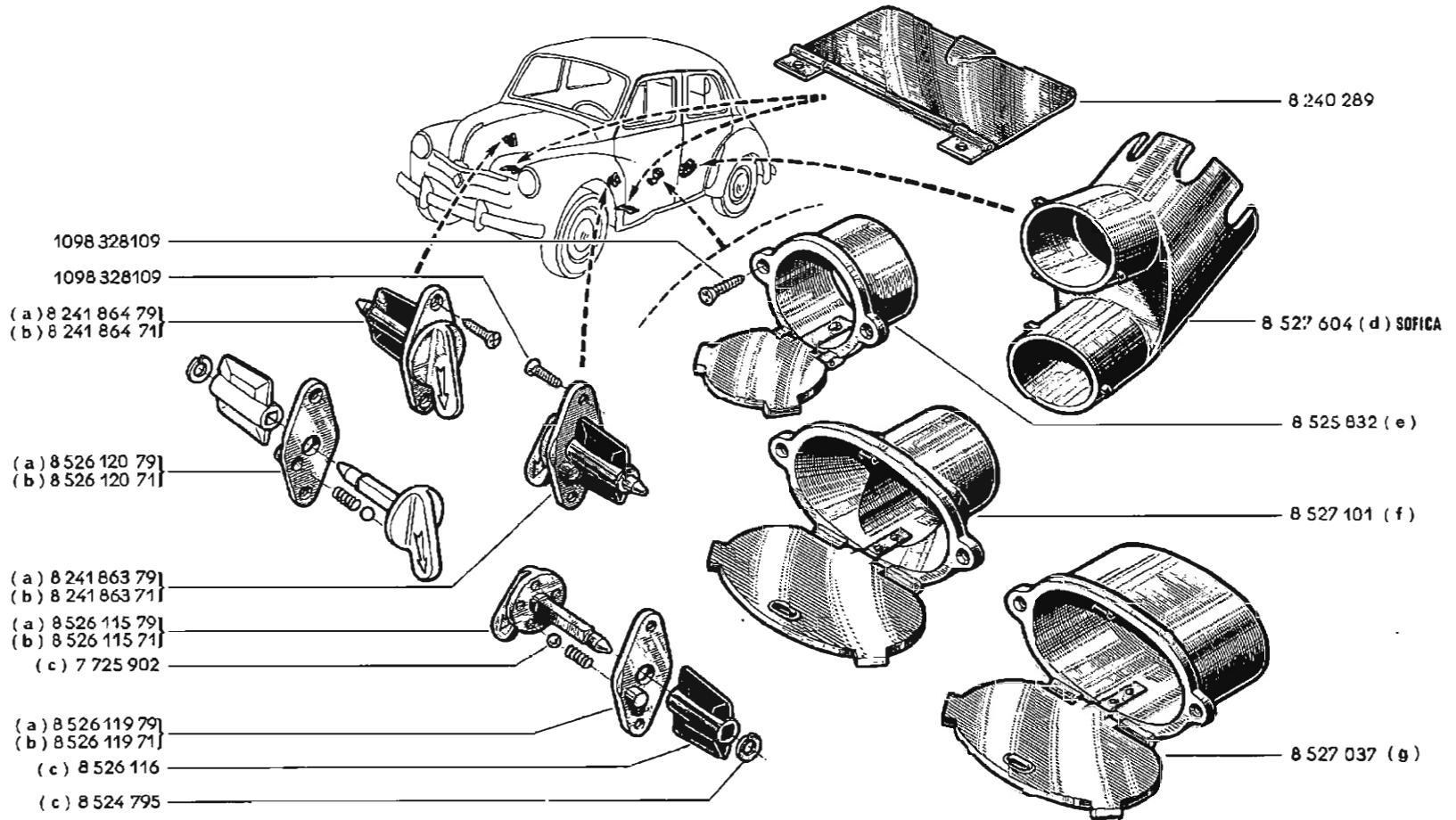

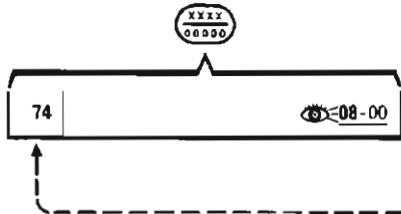

	n°...	⇒	n°...	⌘	⌘	!!!
(a)	381186 VEH		405209			
	405601 VEH		406426			
(b)	405210 VEH		405600			
	406427 VEH		...			
(c)	381186 VEH		...			
(d)	869016 VEH		...			
(e)	301595 VEH		703420	74		
(f)	703421 VEH		...			
(g)	703421 VEH		...			293

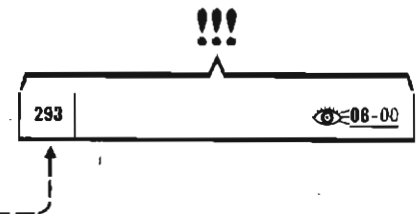

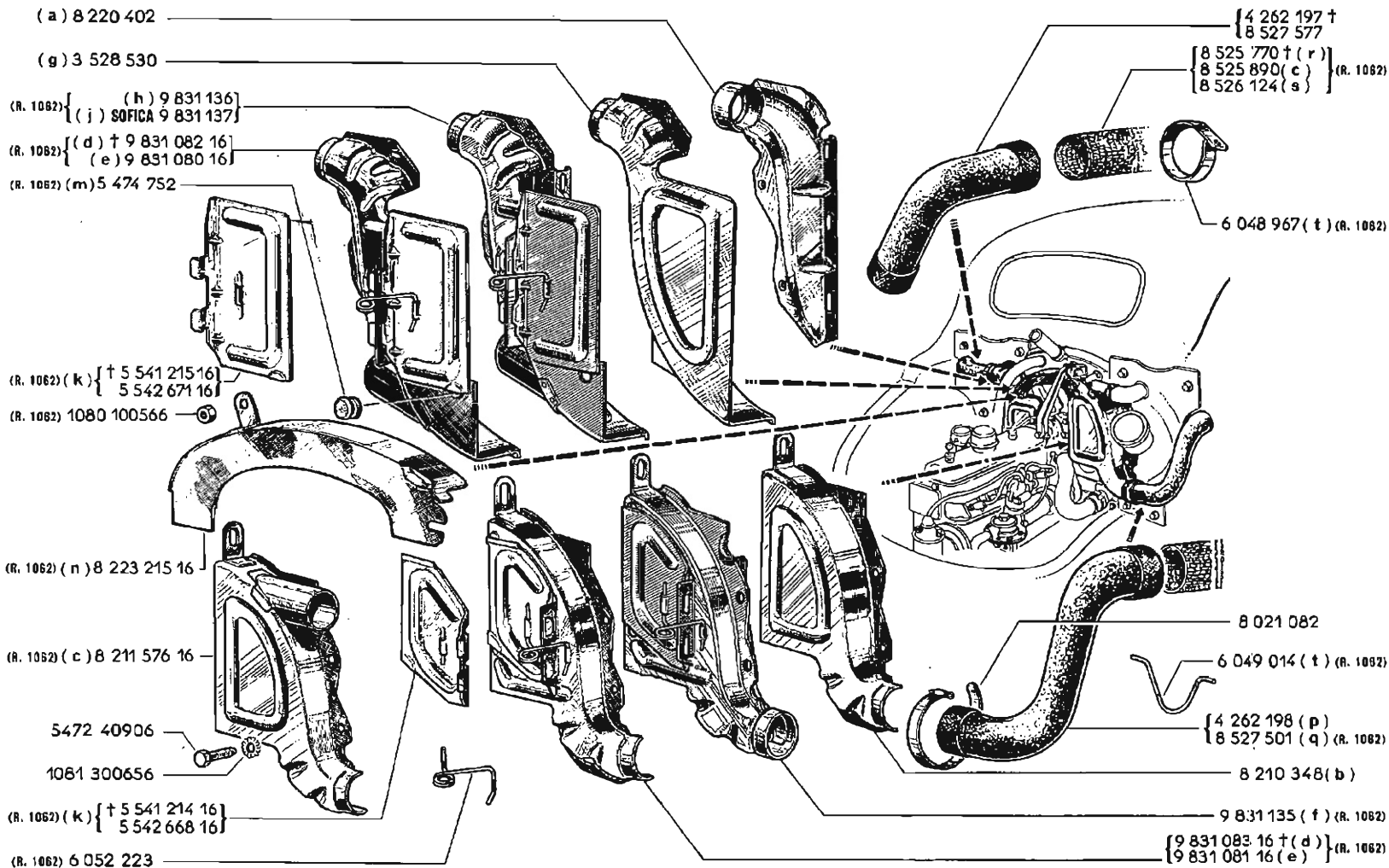

	n°...	n°...			
(a) R.1060 R.2070 R.2071 R.1062	1 VEH	864828			
(b) R.1060 R.2070 R.2071 R.1062	1 VEH 252001 VEH	251921 258532	74		
(c)	251922 VEH 258533 VEH 405601 VEH	252000 405209 406426		74	
(d)	405210 VEH	405600			
(e)	405210 VEH 406427 VEH	405600 864828			
(f)	864829 VEH	...			
(g) R.1060 R.2070 R.2071 R.1062	1 VEH 405601 VEH	405209 406426			
(h)	864829 VEH	869015			
(j)	869016 VEH	...			
(k)	405210 VEH 406427 VEH	405600 491501			
(m)	405210 VEH 406427 VEH	405600 ...			
(n)	251922 VEH 258533 VEH	252000 ...		74	
(p) R.1060 R.2070 R.2071 R.1062	1 VEH	812763			
(q)	812764 VEH	...			
(r)	251922 VEH	252000			
(s)	406427 VEH	...			
(t)	251922 VEH 405601 VEH	405209 405426			

XXXX
00000

74
08-00



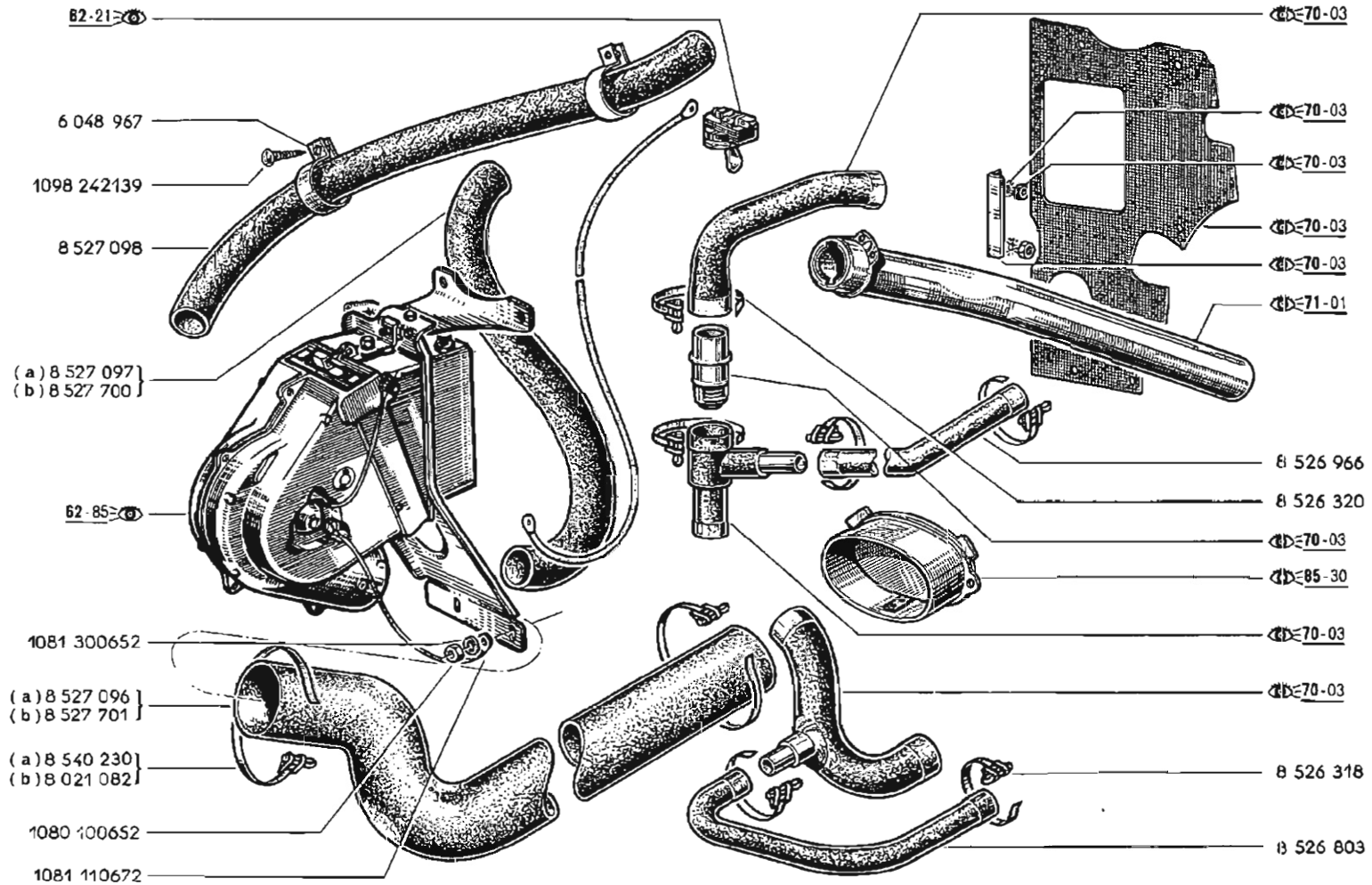

(a) VEH n° 1 ⇨ VEH n° 869015
 (b) VEH n° 869016 ⇨ VEH n° ...

9 831 121

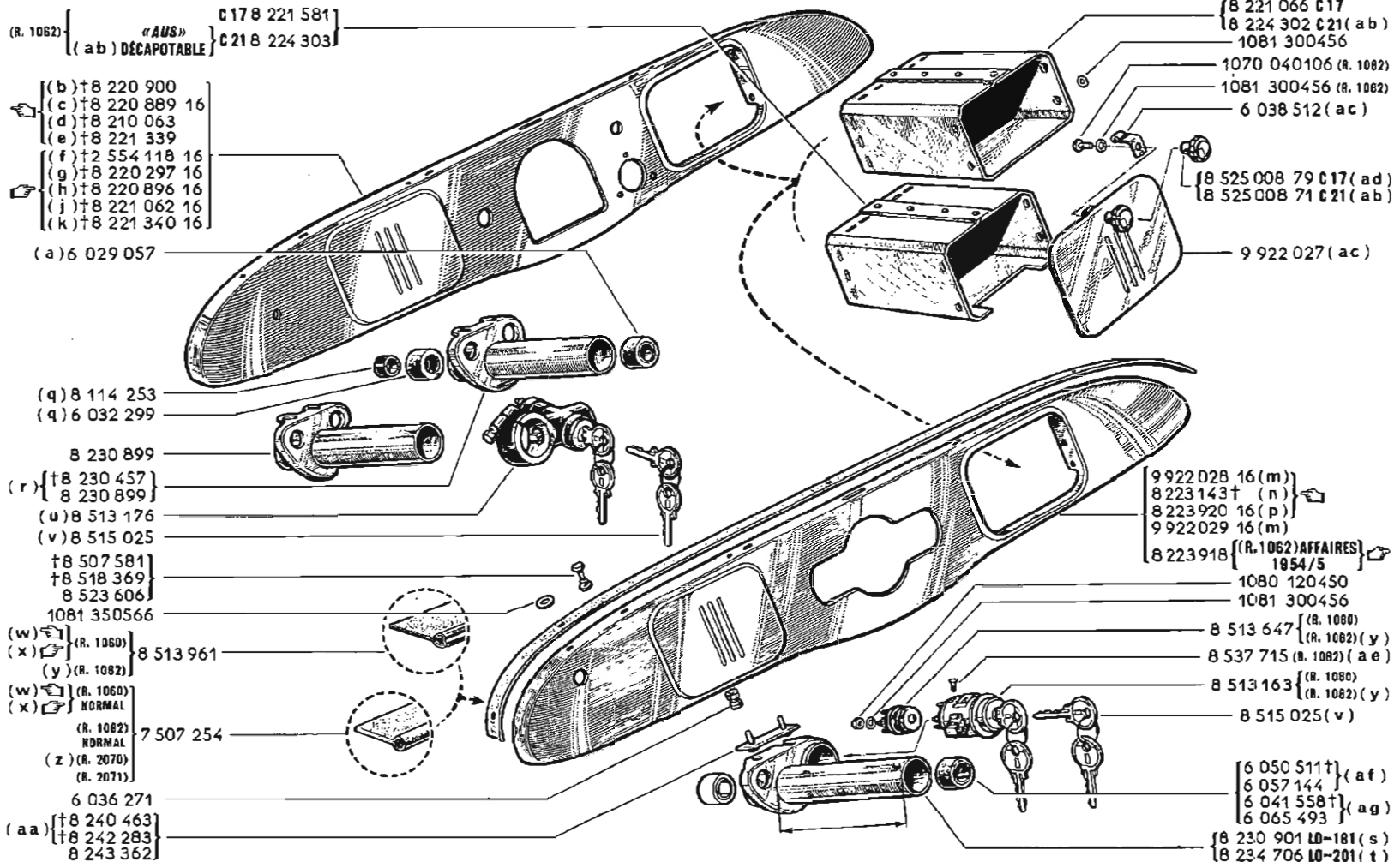

	n°...	n°...	!!!
(a) R.1060 R.1062 R.2070 R.2071			20
(b) R.1060 NORMAL R.2070	1 VEH 1 VEH	64483 8012	
(c) R.1060 LUXE GD LUXE	1 VEH 1 VEH	64483 64483	
(d) R.1060 NORMAL R.1060 LUXE R.1060 TOIT OUVRANT R.1062 NORMAL LUXE LUXE AFFAIRES TOIT OUVRANT R.2070 R.2071	64484 VEH 64484 VEH 64484 VEH 1 VEH 1 VEH 1 VEH 1 VEH 8013 VEH 1 VEH 3530 5100 5100 5100 ... 165	
(e) R.1060 GD LUXE R.1060 DÉCAPOTABLE R.1060 TOIT OUVRANT R.1062 GRAND LUXE R.1062 DÉCAPOTABLE R.1062 TOIT OUVRANT			
(f) R.1060 NL LUXE	1 VEH	64483	
(g) R.2070	1 VEH	8012	
(h) R.1062			71
(j) R.1060 NORMAL R.1060 LUXE R.1060 TOIT OUVRANT R.1062 NORMAL R.1062 AFFAIRES R.1062 LUXE R.1062 AFFAIRES R.1062 LUXE R.1062 TOIT OUVRANT R.2070 R.2071	64484 VEH 64484 VEH 64484 VEH 1 VEH 1 VEH 1 VEH 1 VEH 1 VEH 1 VEH 8013 VEH 1 VEH 3530 3530 3530 5100 5100 5100 ... 165	
(k) R.1060 GD LUXE R.1060 TOIT OUVRANT R.1060 DÉCAPOTABLE R.1062 GRAND LUXE R.1062 TOIT OUVRANT R.1062 DÉCAPOTABLE			
(m) R.1060 R.2070 R.2071 R.1062 NORMAL R.1062 LUXE R.1062 AFF. 1952/3			146 148 146 148 146 148

XXX
00000

20	08-00
71	08-00

!!!

146	8535502 -1-	8535133 -1-
-----	-------------	-------------







	n°...	n°...	!!!
(m) GRAND LUXE			32 148
SPORT			32 148
TOIT OUVRANT			32 148
DÉCAPOTABLE			32 148
(n) R.1062 AFF. 1954			32
(p) R.1062 AFF. 1954/5	1 VEH	532892	
(q) R.1060			
R.1062	1 VEH	65549	21
R.2070			
R.2071	1 VEH	2400	
(r) R.1060 NORMAL	1 VEH	21785	
LUXE			
R.2070	1 VEH	2789	
(s) R.1060 NORMAL	21785 VEH	...	148
R.1060 LUXE	21786 VEH	...	148
GRAND LUXE			148
TOIT OUVRANT			148
DÉCAPOTABLE			148
R.1062 NORMAL			148
R.1062 LUXE			148
R.1062 GRAND LUXE			148
SPORT			32 148
TOIT OUVRANT			32 148
DÉCAPOTABLE			32 148
AFFAIRES	1 VEH	405209	148
AFFAIRES	405601 VEH	406426	148
R.2070	2790 VEH	...	148
R.2071			148
(t) R.1062 AFFAIRES	405210 VEH	405600	
R.1062 AFFAIRES	406427 VEH	532892	
(u) R.1060 LUXE	7816 VEH	21785	
(v) R.1060			32
R.1062			
(w)	33704 VEH	...	
(x)	3731 VEH	...	
(y)			32
(z)	5564 VEH	...	
(aa) R.1060 NORMAL	7816 VEH	21785	
LUXE			
R.1062	254515 VEH	532892	32
R.2070	1115 VEH	2789	
(ab)	405210 VEH	405600	
	406427 VEH	532892	32
(ac) R.1062	27573 VEH	532892	32
(ad) R.1062	27573 VEH	405209	
R.1062	405601 VEH	406426	
(ae)			32
(af) R.2071	2401 VEH	...	
(ag) R.1082	65550 VEH	...	21

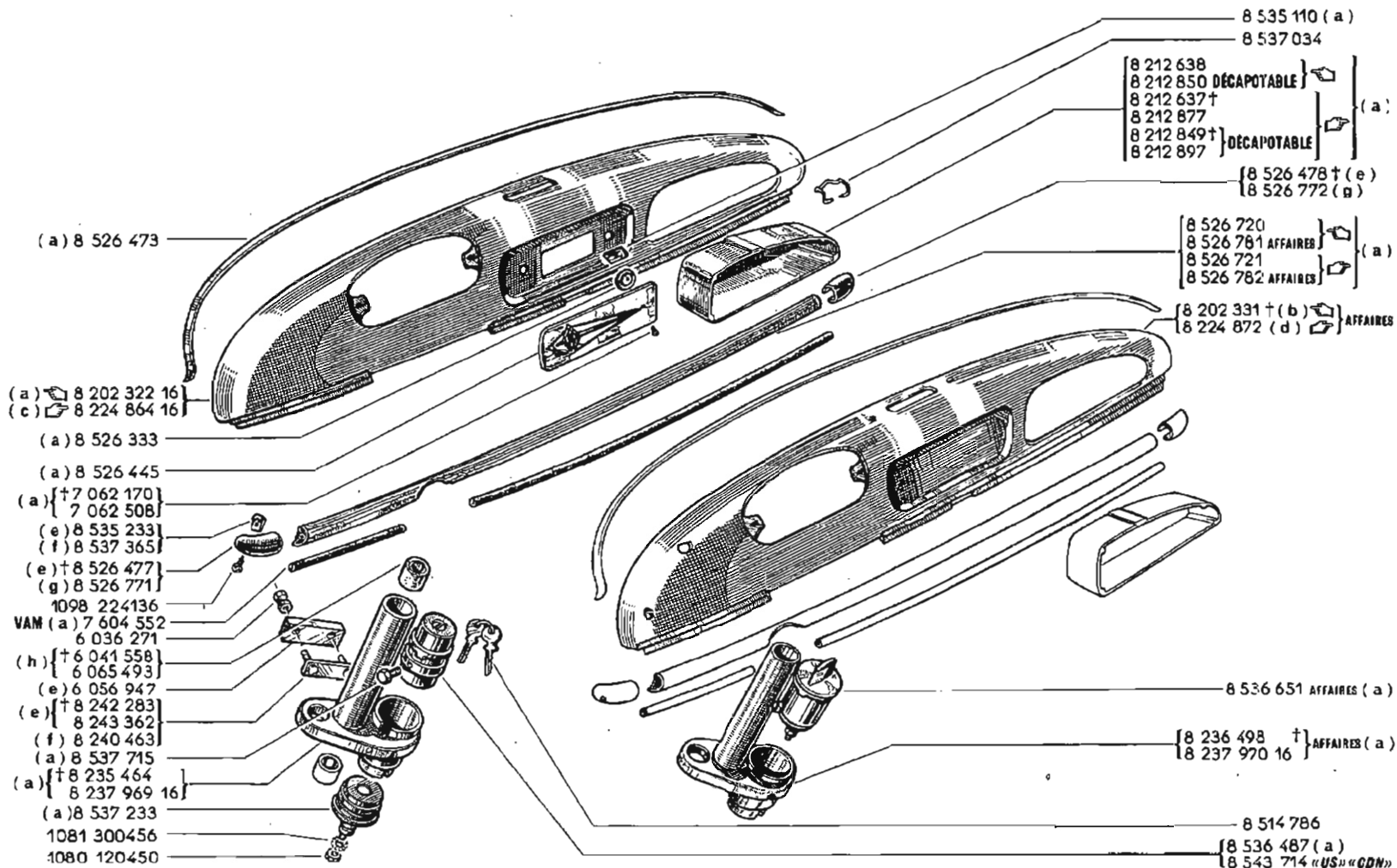

XXXX 00000	
21	08-00
32	08-00

!!!		
148		8535502 - 1 - 8535133 - 1 -
148		8240483 - 1 -



21	 08-00
32	 08-00

	n°...	n°...		
(a)			32	
(b)				190
(c)			32	147
(d)				147
(e)	532893 VEH	631207	32	
SPORT	532893 VEH	631486	32	
DÉCAPOTABLE	532893 VEH	632235	32	
TOIT OUVRANT	532893 VEH	632235	32	
(f)	631208 VEH	...		
SPORT	631487 VEH	...		
DÉCAPOTABLE	632236 VEH	...		
TOIT OUVRANT	632236 VEH	...		
(g)	631208 VEH	...		221
SPORT	631487 VEH	...		221
DÉCAPOTABLE	632236 VEH	...		221
TOIT OUVRANT	632236 VEH	...		221
(h)			21	

147		8535503 -1- 8535134 -1-
190		 06-00
221		1098 224136 -1- 8537365 -1-



85.65

B P.R. 685

85.65

B P.R. 685

(j) 8 516 660
(n) 8 513 783

(j) 5 526 622

(k) { † 4 265 764
8 525 339 }

(p) 8 525 007

(m) { † 4 265 766
8 525 341 }

(R. 1062) 8 526 631

GD LUXE } VAM (u) 8 516 285
SPORT } (R. 1062) (v) † 5 530 021

(r) 8 516 277

(a) 8 517 819
(R. 1062) (e) 8 522 691

GRAND LUXE (R. 1060) (R. 1062) † 5 502 986
SPORT { (y) 6 040 714 }

GRAND LUXE SPORT (y) 7 059 054

6 035 256

1081 300 456

1080 100 550

(a) 4 261 305

(a) 4 261 306

(a) 4 261 307

(a) 4 261 308

(R. 1062) AFFAIRES } † 6 032 612
(1952-1953) } 5 552 743

(R. 1062) (b) 8 241 559

1081 350 556

(g) 9 901 034

(a) 6 030 690

(a) 5 524 627

1081 300 556

RENAULT

Renault

Grand Luxe

ENERVAGE AUTOMATIQUE
FERLEC

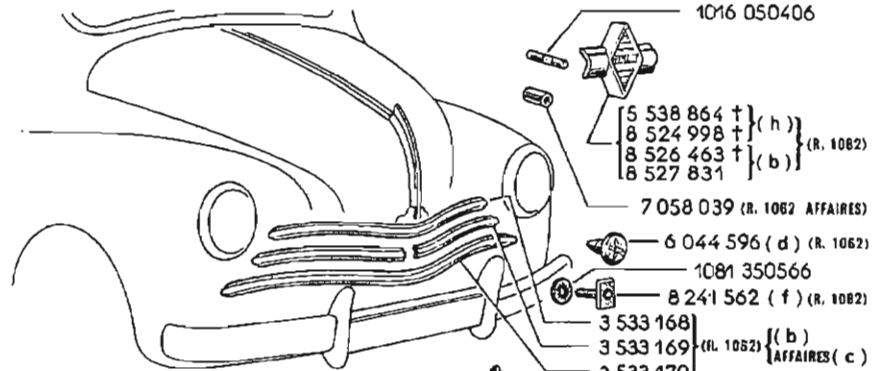

1016 050406

{ 5 538 864 †
8 524 998 † (h)
8 526 463 † (b)
8 527 831 } (R. 1062)

7 058 039 (R. 1062) AFFAIRES

6 044 596 (d) (R. 1062)

1081 350 556

8 241 562 (f) (R. 1062)

3 533 168
3 533 169 (R. 1062) (b)
3 533 170 } AFFAIRES (c)

1098 228109

8 516 361 (R. 1060) (R. 1062)

8 516 362 (R. 1060) (R. 1062)

8 526 662 (R. 1060, R. 1062,
GD LUXE, SPORT) C 24

7 507 266 † C 23

7 507 265 † C 18

7 507 282 C 18

7 507 286 C 21 (z)

7 507 287 C 14

7 507 480 C 17

7 507 444 C 21 (aa) (R. 1062)

7 507 481 C 14 } AFFAIRES

7 507 581 C 11

7 507 582 C 18 (ab)

7 507 489 C 14

7 507 585 C 24 (ac)

{ 8 516 286 (u) VAM } GD LUXE
{ 5 530 022 † (v) (R. 1062) } SPORT

{ 8 516 479 † (R. 1060) } GRAND LUXE
{ 8 526 403 (u) } SPORT

{ 8 516 483 (x) (R. 1062) }
{ 3 528 241 16 (q)
3 531 765 † GRAND LUXE
3 530 083 04 (r)

{ 5 472 409 (s)
8 528 292 (t) (R. 1062)

{ 3 528 242 16 (q)
3 531 766 † GRAND LUXE

{ 3 530 084 04 (r)

C 11
C 14
C 16
C 17
C 18
C 21
C 23
C 24

100-00

	n°...	n°...	!!!
(a) R. 1060 R. 2070 R. 2071 R. 1062	1 VEH	283715	
(b)	283716 VEH	...	
(c)	405210 VEH 406427 VEH	405600 ...	
(d) SPORT TOIT OUVRANT DÉCAPOTABLE AFFAIRES AFFAIRES	283716 VEH 283716 VEH 283716 VEH 405210 VEH 406427 VEH	467283 467424 467942 405600 467568	
(e) SPORT TOIT OUVRANT DÉCAPOTABLE AFFAIRES	467284 VEH 467425 VEH 467943 VEH 467569 VEH	
(f) AFFAIRES SPORT TOIT OUVRANT DÉCAPOTABLE LUXE GRAND LUXE NORMAL	405210 VEH 406427 VEH 283716 VEH 283716 VEH 283716 VEH 283716 VEH 283716 VEH	405600	
(g) R. 1060 R. 2070 R. 1062	1 VEH	283715	32
(h)	283716 VEH	532892	32
(j) R. 1060 R. 2070 R. 1062 R. 2071	1 VEH 1 VEH	40200 1700	
(k) R. 1062 R. 2071	40201 VEH 1701 VEH	105372 3368	
(m) R. 1060 R. 1062	40201 VEH	105372	

XXXX
00000

32 | 08-00



	n°...	n°...	!!!
(n) R.1060 6D LUXE R.1062 R.2071	40201 VEH 1701 VEH	105372 3368	
(p) R.1060 R.2070 R.1062 R.2071	40201 VEH 1701 VEH	105372 3368	
(q) R.1060 NORMAL R.1062 NORMAL R.1062 SPORT R.2070 R.2071	734972 VEH	...	36 36
(r) R.1060 6D LUXE R.1062 6D LUXE R.1062 SPORT	1 VEH	734971	
(s) R.1060 R.1062 R.2070 R.2071	1 VEH	672177	
(t)	672178 VEH	...	
(u) R.1060 R.1062 R.1062 R.1062	1 VEH 19829 VEH 22347 VEH	9200 21337 ...	
(v)	9201 VEH 21338 VEH	19828 22346	267
(w)	9201 VEH 21338 VEH	19828 22346	268
(x)	9201 VEH 21338 VEH	19828 22346	
(y) R.1060 R.1062	1 VEH	734970	
(z)	1 VEH	532892	32
(aa)	532893 VEH	666022	32
(ab)	666023 VEH	710469	
(ac)	710470 VEH	...	

XXXX
00000

32
08-00

!!!

36	⊕	5472409 -4-
267	⊕	8516285 -2-
268	⊕	8516286 -2-



(a) 9 986 347

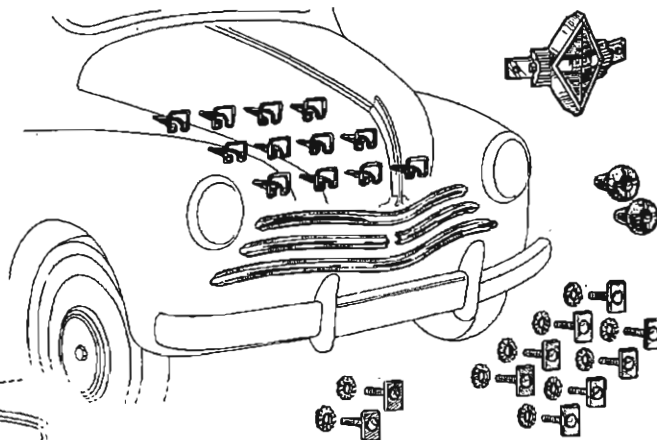
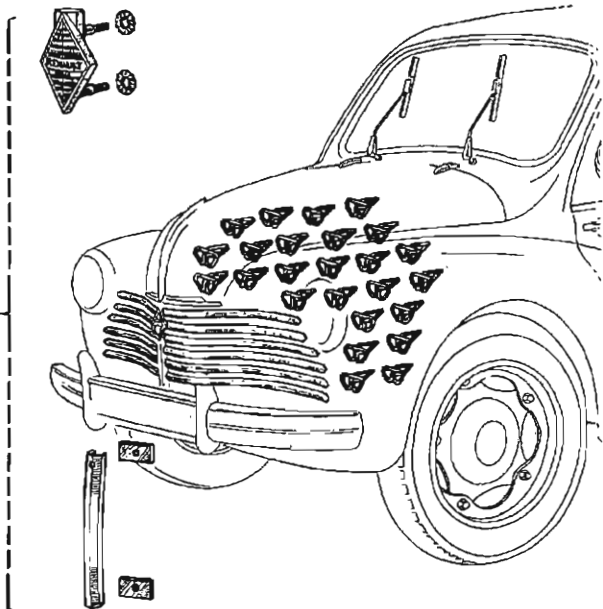

9 986 349 (b)

- (a) { R 1062 VEH n° 1 ⇨ VEH n° 283715
- R 2070
- R 2071
- (b) R 1062 VEH n° 283716 ⇨ VEH n° ...

(R. 1062) (d) 6 029 984

(R. 1060) (aa) 8 114 604
(ab) 6 034 688

(R. 1060) (aa) 8 114 603
(ab) 6 034 688

(R. 1060) { US † 9 826 046
(R. 1062) { † 9 826 031

(R. 1062 SERVICE 1952) † 9 826 062
† 9 826 112

(k) † 5 524 805

(m) (R. 1060) † 4 262 601
(n) (R. 2070) (p)

(k) † 5 524 806

(m) (R. 1060) † 4 262 602
(n) (R. 2070) (p)

(q) (R. 1060) † 8 220 911
(r) (R. 2070) (s)

(R. 1060) (t) † 8 221 346
† 8 222 154

(u) † 8 221 711

(R. 1060) (R. 1062) US 3 530 397

(a) 3 528 069
(e) 3 530 082

(R. 1062 SERVICE AFFAIRES) 3 532 640

† 8 513 525
8 220 966

(R. 1061) (d) 8 226 875

(R. 1060) (ae) † 8 231 229
(af) 8 235 189

(x) (R. 1060) 8 240 335
(y) (R. 2070)

(a) 6 031 682 04
(e) 7 053 041

(R. 1061 SERVICE AFFAIRES) 7 053 183

(ak) 8 223 663
«B» (am) † 8 224 475
(R. 1062) (an) 8 224 798
US † 8 221 049
8 221 754

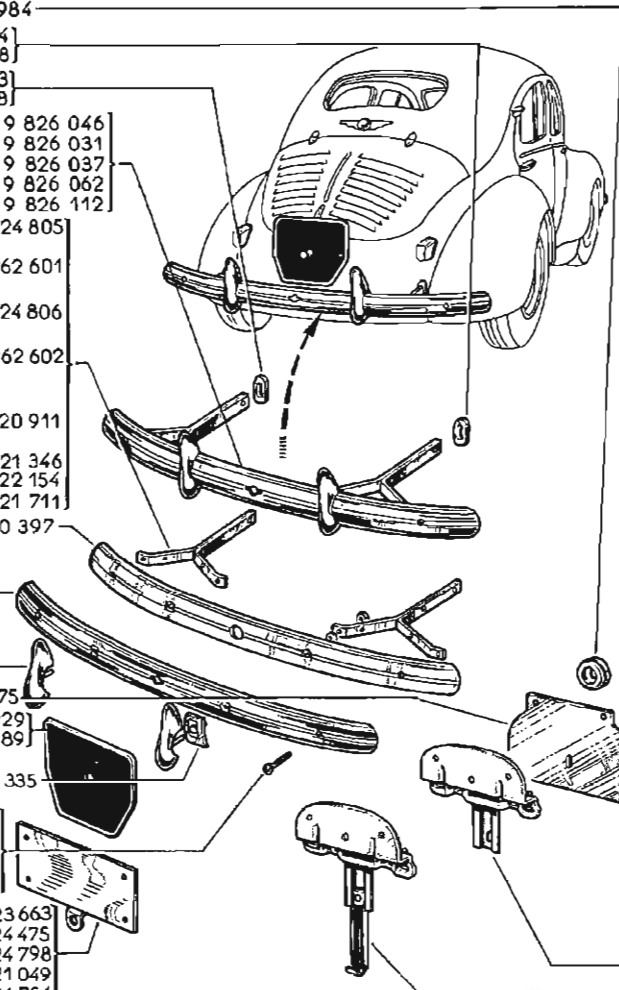

4 261 167 † (a)
4 261 168 †
8 220 783 † (f)
8 221 347 † (g)
8 222 157 † (h)
8 221 350 †
8 222 156

1080 100856
1081 340859
1023 080256

5 491 494 (R. 1062 SERVICE AFFAIRES)

9 826 045 † US (R. 1062)
9 826 047 (R. 1060)

9 826 030 †
9 826 043
9 826 061 † (R. 1062 SERVICE 1952)

9 826 111 †
3 528 070 (a)
8 210 701 † (b) (R. 1060)

3 530 396 (c)
3 537 895 † (d) SPORT
3 530 082 US (R. 1062)

3 532 638
3 537 896 † (d) AFFAIRES (R. 1062)

5 530 097 (j)
4 261 167 † (a)

4 261 168 †
8 220 783 † (f)

8 221 347 † (g)
8 222 157 † (h)

8 221 349 †
8 222 155

3 530 256 †
3 530 399 † (R. 1060)

8 210 759 † (R. 1062 US)
8 210 884 (v)
8 213 875 (w)

8 230 609 † (ac)
5 537 830 (ad)

3 530 088 16 (R. 1060, R. 1062 GRAND LUXE)
8 230 157 (a)

9 949 045 (d) (R. 1062) †
8 238 300 (R. 1060, R. 1062) †

8 232 153 (aj)
8 221 753 (ag) (R. 1062 US)

8 237 892 (R. 1062 «US»
«D» «A»)

9 949 046 † (d) (R. 1062)

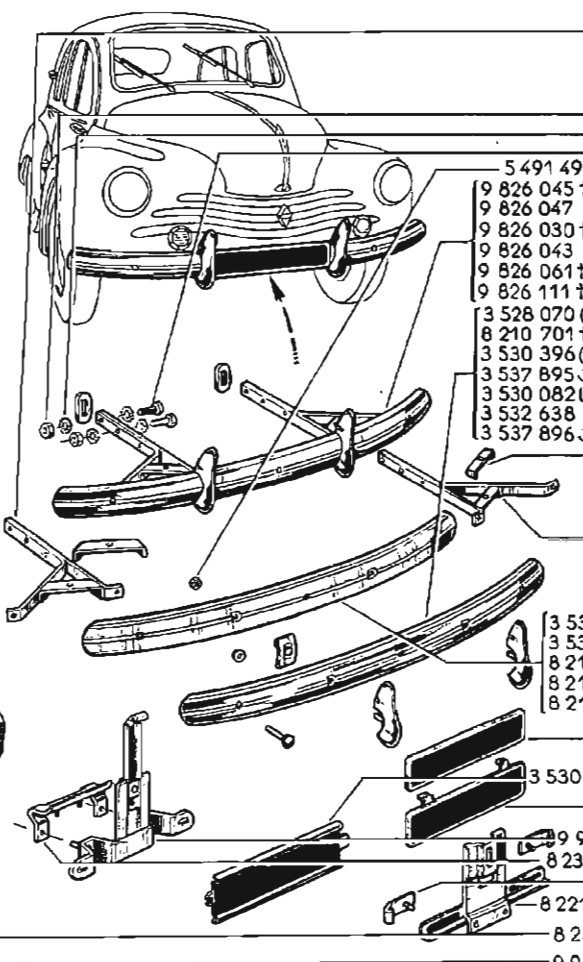

	n°...	n°...	!!!
(a) R.1060 R.2070	1 VEH 1 VEH	9983 1447	
(b)	9984 VEH	...	
(c) R.1060 R.1060 GD LUXE«US»	9984 VEH	...	37
R.1062			37
R.2070	1448 VEH	...	37
R.2071			37
(d)	861035 VEH	...	
(e) R.1060 R.1060 «US» R.1062 R.2070 R.2071	9984 VEH 1448 VEH	
(f) R.1060 R.2070	9984 VEH 1448 VEH	95790 9690	
(g) R.1060 R.2070	95791 VEH 9691 VEH	
(h) R.1060 R.2070 R.2071 R.1062 R.1062	 1 VEH 405601 VEH	 405209 408426	
(j) R.1060 GD LUXE R.1062 GD LUXE R.1062 GD LUXE R.1062 SPORT R.1062 SPORT	 1 VEH 405601 VEH 1 VEH 405601 VEH	 405209 406426 405209 406426	149 149 149 149
(k) R.1060 R.2070	1 VEH 1 VEH	9983 1447	149 149
(m)	9984 VEH/CAR	19810	149
(n)	9984 VEH/CAR	1885	149
(p)	1448 VEH/CAR	2750	149
(q)	19811 CAR / VEH	95790	149
(r)	1886 CAR / VEH	95790	149
(s)	2751 CAR / VEH	9690	149
(t)	95791 VEH	...	

!!!	
37	⊗ ≤ 06-00
149	⊗ ≤ 06-00



	n°...	→	n°...	!!!	!!!
(u) R.1060 NORMAL	95791 VEH		...		
R.1060 LUXE	95791 VEH		...		
R.1060					
R.1062					
R.2071					
R.2070	9691 VEH		...		
(v)	1 VEH		861034		
(w)	861035 VEH		...		
(x)	9984 VEH/CAR		20326		
(y)	9984 VEH/CAR		1937		
(z)	1448 VEH/CAR		2861		
(aa)	1 CAR		906		
(ab) R.1060	907 CAR		...		
R.1062					
R.2070					
R.2071					
(ac) R.1060	9884 VEH		...		38
R.1082					38
R.2070	1448 VEH		...		38
R.2071					
(ad) R.1060	9884 VEH		...		38
R.1062	1 VEH		861034		38
R.1062 MÉTROPOLE	861035 VEH		...		
R.1062 «US» TRANSIT	861035 VEH		...		
R.2070	1448 VEH		...		38
R.2071					38
(ae)	64484 VEH		...		
(af) R.1060	64484 VEH		...		
R.2070	8013 VEH		...		
R.2071					
R.1082					
(ag)	88269 VEH		861034		
(aj) R.1062 «US»	28529 VEH		861034		
R.2071 «US»	2966 VEH		...		
R.1062 «D»	840861 VEH		...		
R.1062 «A»	840861 VEH		...		
(ak) R.1060					150
R.2070					150
R.1082	1 VEH		427466		
(am)	427467 VEH		...		
(an)	427467 VEH		861034		

		!!!
38		08-00
150		8521253 -1- 8021014 -1-



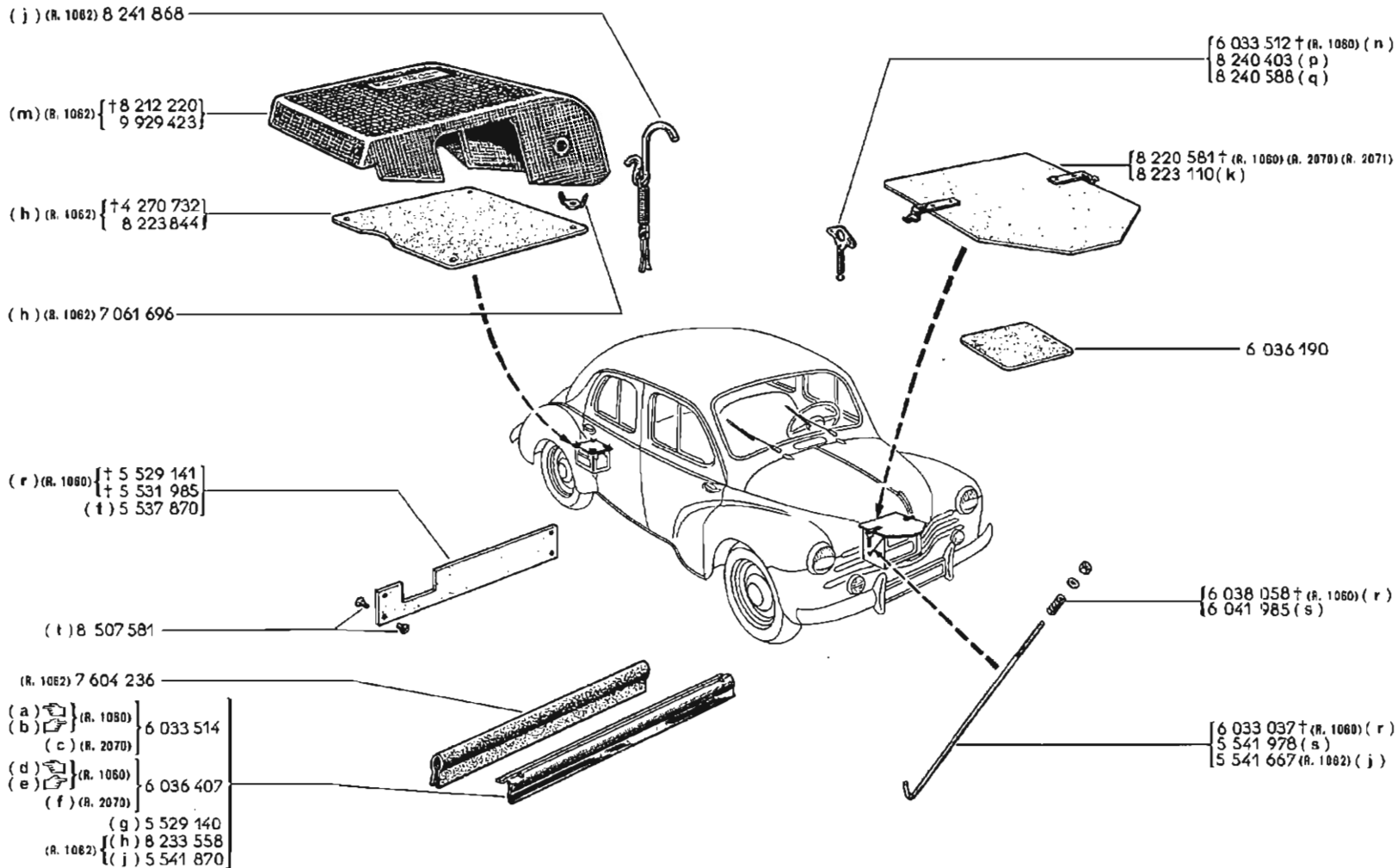

	n°...	⇨	n°...	⚡	⚡	!!!
(a)	1 CAR		24468			
(b)	1 CAR		2138			
(c)	1 CAR		3394			
(d)	24469 VEH		81378			
(e)	2139 VEH		81378			
(f)	3395 VEH		9182			
(g) R.1060	81379 VEH		...			
R.1062	1 VEH		283715			
R.2070	9183 VEH		...			
R.2071						
(h)	283716 VEH		397463			
(j)	397464 VEH		...			
(k) R.1060						
R.2070						
R.2071						
R.1062	1 VEH		283715			
(m)	397464 VEH		...			
(n)	1 VEH		69631			
(p) R.1060	1 VEH		69631			
R.2070	1 VEH		8484			
(q) R.1060	69632 VEH		...			
R.1062	1 VEH		283715			
R.2070	8485 VEH		...			
R.2071						
(r)	81379 VEH		...			
(s) R.1060	81379 VEH		...			
R.1062	1 VEH		397463			
R.2070	9183 VEH		...			
R.2071						
(t) R.1060	81379 VEH		...			
R.1062						
R.2071						
R.2070	9183 VEH		...			

100.00

A

P. R. 685



C 11



C 14



C 17

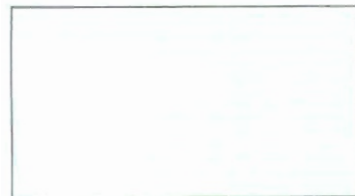

C 20



C 12



C 15



C 18



C 21



C 23

100.00

A

P. R. 685

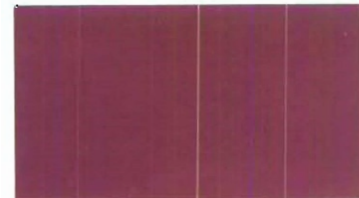

C 13



C 16



C 19



C 24

100.00

A P.R. 685



C1 475 123 5001 **A**

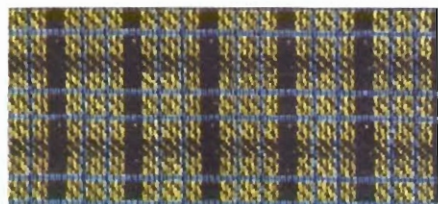

C4 471 703 1254 **B**



C7 475 460 4051 **A**

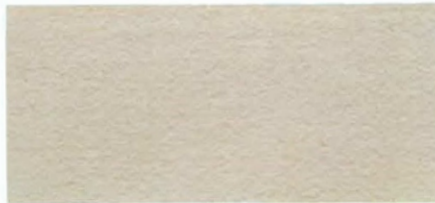

C2 471 801 1225 **A**



C5 471 701 1252 **B**

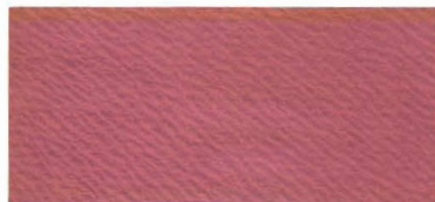

C8 475 460 4048 **A**



C10 484 379 1050 **C**

100.00

A P.R. 685



C3 474 926 1563 **A**

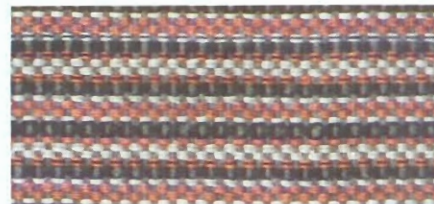

C6 471 701 1251 **B**



C9 475 460 4054 **A**

